

NAME: INDEX NO:

SCHOOL: DATE :

CANDIDATE'S SIGNATURE:.....

121/1
MATHEMATICS
PAPER 1
JULY / AUGUST 2014
TIME: 2½ HOURS

KURIA EAST SUB-COUNTY JOINT EXAMINATIONS COUNCIL 2014

Kenya Certificate of Secondary Education (KCSE)
MATHEMATICS ALT A
PAPER 1
TIME: 2½ HOURS

INSTRUCTIONS TO CANDIDATES

- a) Write your **Name, School** and **Index Number** in the spaces provided at the top of this page.
- b) **Sign** and write the **Date** of examination in the spaces provided above.
- c) This paper contains **TWO** sections: section **I** and section **II**
- d) Answer **all** the questions in Section I and only **FIVE** questions from section II.
- e) Show **all** the steps in your calculations, giving your answers at each stage in the spaces provided below each question.
- f) Non-programmable silent electronic calculators and KNEC mathematical tables **may be** used except where stated otherwise.
- g) Candidates should check to ensure that all questions are printed from question 1 to 24.

FOR EXAMINER'S USE ONLY:

Section I

1	2	3	4	5	6	7	8	9	10	11	12	13	14	15	16	TOTAL

Section II

17	18	19	20	21	22	23	24	TOTAL

GRAND TOTAL

SECTION 1 (50 MARKS)

Attempt ALL Questions in this section in the spaces provided.

1. Evaluate without using Mathematical tables or a calculator: (3mks)
 $0.008 \times 1.23 \times 3.5$
 2.87×0.056 expressing the answer as a fraction in its simplest form.

2. Kenya Commercial Bank buys and sells Japanese Yen in Kenya Shillings at the rates shown below:

Buying	Selling
0.5024	0.5446

A Japanese tourist at the end of his tour in Kenya was left with Kshs. 30,000 which he changed to Japanese Yen through KCB. How many Japanese Yen did he get? (2mks)

3. Without using mathematical tables or calculator, evaluate: (3mks)
 $6 \log_2 3\sqrt{64} + 10 \log_3 5\sqrt{243}$

4. Simplify: $\frac{9t^2 - 25a^2}{6t^2 + 19at + 15a^2}$

(3mks)

5. John bought two shirts and three pairs of trousers at Ksh. 1,750. If he had bought three shirts and two pairs of trousers, he would have saved Ksh. 250. Find the cost of a shirt and a trouser. (3mks)

6. Three litres of water (density 1g/cm^3) is added to twelve litres of alcohol (density 0.8g/cm^3), what is the density of the mixture? (3mks)

7. The gradient of the tangent to the curve $y = ax^3 + bx$ at point (1,1) is -5. Calculate the value of a and b. (4mks)

8. List the integral values of x which satisfy the inequalities below. (3mks)
 $2x + 21 > 15 - 2x \geq x + 6$

9. Charles keeps goats and sheep. The number of goats exceeds the number of sheep by 4. During drought $\frac{1}{4}$ of the goats and $\frac{1}{6}$ of the sheep died. If he lost a total of 61 animals, how many animals did he have originally? (4mks)

10. Using a pair of compasses and a ruler only:

(a) Construct a triangle ABC such that $AB = 6\text{cm}$, $BC = 8\text{cm}$ and $\angle ABC = 135^\circ$. (2mks)

(b) Construct the height of triangle ABC in (a) above taking BC as the base and measure the height. (3mks)

11. Given that x is an acute angle and $\cos x = \frac{2\sqrt{5}}{5}$ without using mathematical tables or a calculator find $\tan x$. (2mks)

12. Point T is the midpoint of a straight line AB. Given that the position vectors of A and T are $i - j + k$ and $2i + 1\frac{1}{2}k$ respectively, find the position vector of B in terms of i , j and k . (3mks)

13. Five people can build 3 huts in 21 days. Find the number of people, working at the same rate that will build 6 similar huts in 15 days. (2mks)

14. Find the equation of line L_1 which is perpendicular to the line $3y + 2x = 6$ and cuts the x-axis at -3 units. (3mks)

15. Under a shear with x-axis invariant the point (3,2) is mapped onto (-2,2). Find the image of point (4,4) under the same transformation. (3mks)

16. The angle of elevation of the top of a building from a point P is 45° . From a point Q, which is 10M from P towards the base of the building, the angle of elevation is 48° . Calculate the height of the building. (4mks)

SECTION II (50 MARKS)
Answer any five questions in this section

17. Three business partners; Kamau, Tatwa and Makau contributed Ksh. 100,000, Ksh. 80,000 and Ksh. 50,000 respectively to start a business. After one year, the business realized a profit which they shared in the ratio of their contributions.

(a) If Makau's share of profit was Kshs. 20,000, how much was the total amount of profit?
(3mks)

(b) At the beginning of the second year, Makau boosted his shares by Ksh. 10,000. If the business profit increased by 20% at the end of the second year, calculate:-
(i) Kamau's share of the profit. (4mks)

(ii) The difference between Kamau's and Tatwa's share of profit. (3mks)

18. The diagram below represents a rectangular swimming pool 25m long and 10m wide. The sides of the pool are vertical.

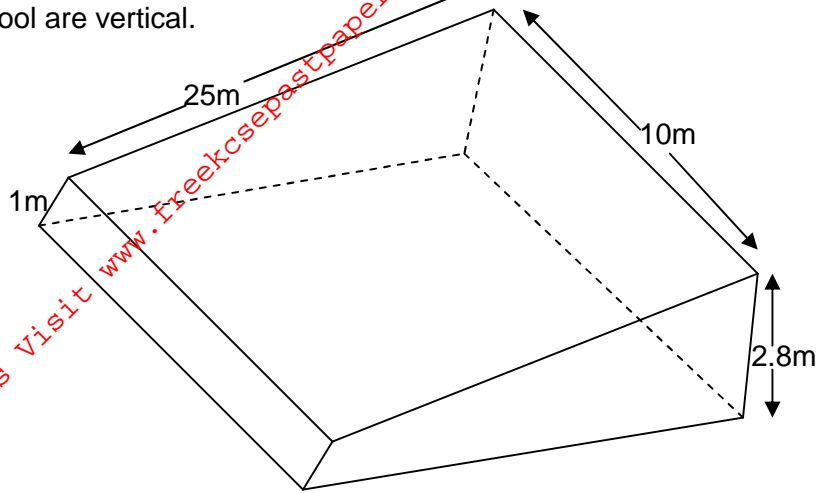

The floor of the pool slants uniformly such that the depth of the shallow end is 1m and at the deep end is 2.8m.

- (a) Calculate the volume of water required to completely fill the pool. (4mks)

- (b) Water is allowed into the empty pool at a constant rate through an inlet pipe. It takes 9 hours for the water to just cover the entire floor of the pool.

Calculate:-

- (i) The volume of the water that covers the floor of the pool. (3mks)

- (ii) The time needed to completely fill the remaining part of the pool. (3mks)

19. The length and breadth of a rectangle are given as $(6x - 1)$ and $(x - 2)$ metres respectively. If the length and breadth are each increased by 4 metres, the new area is three times that of the original rectangle.

(a) Form an equation in x and solve it. (4mks)

(b) Find the dimensions of the original rectangle. (2mks)

(c) Express the increase in area as a percentage of the original area. (4mks)

20. The distance S metres from a fixed point O covered by a particle after t seconds is given by the equation; $S = t^3 - 6t^2 + 9t + 5$.

(a) Calculate the gradient to the curve at $t = 0.5$ seconds. (3mks)

(b) Determine the values of S at the maximum and minimum turning points of the curve. (4mks)

(c) On the space provided, sketch the curve of $s = t^3 - 6t^2 + 9t + 5$. (3mks)

21. (a) Town B is 40m from town A on a bearing of 042° . Town C is 32km from town A on a bearing of 350° . Another town D is 21km from town A and on a bearing of 200° . By means of scale drawing, show the positions of town A, B, C and D. (Use A scale of 1cm rep 5km).

(6mks)

(b) Use the diagram in (a) above to determine:-

(i) The distance C from B. (1mk)

(ii) The bearing of C from D. (1mk)

(iii) The distance of B from D. (1mk)

(iv) The bearing of B from D. (1mk)

22. (a) Find the inverse of the matrix:

$$\begin{pmatrix} 9 & 8 \\ 7 & 6 \end{pmatrix}$$

(2mks)

(b) In a certain week a businessman bought 36 bicycles and 32 radios for total of Kshs. 227,280. In the following week, he bought 28 bicycles and 24 radios for a total of Kshs. 174,960. Using matrix method, find the price of each bicycle and each radio that he bought. (4mks)

(c) In the third week, the price of each bicycle was reduced by 10% while the price of each radio was raised by 10%. The businessman bought as many bicycles and as many radios as he had bought in the first two weeks. Find by matrix method, the total cost of the bicycles and radios that the businessman bought in the third week. (4mks)

23. A bus and a Nissan left Nairobi for Eldoret a distance of 340km at 7.00a.m. The bus travelled at 100km/h while the Nissan at 120km/h. After 30 minutes, the Nissan had a puncture which took 30 minutes to mend.

(a) Find how far from Nairobi did the Nissan catch up with the bus. (5mks)

(b) At what time of the day did the Nissan catch up with the bus? (2mks)

(c) At what time did the bus reach Eldoret? (3mks)

24. The figure below represents a quadrilateral piece of land ABCD divided into three triangular plots. The length BE and CD are 100m and 80m respectively. Angle ABE = 30° , ACE = 45° and ACD = 100° .

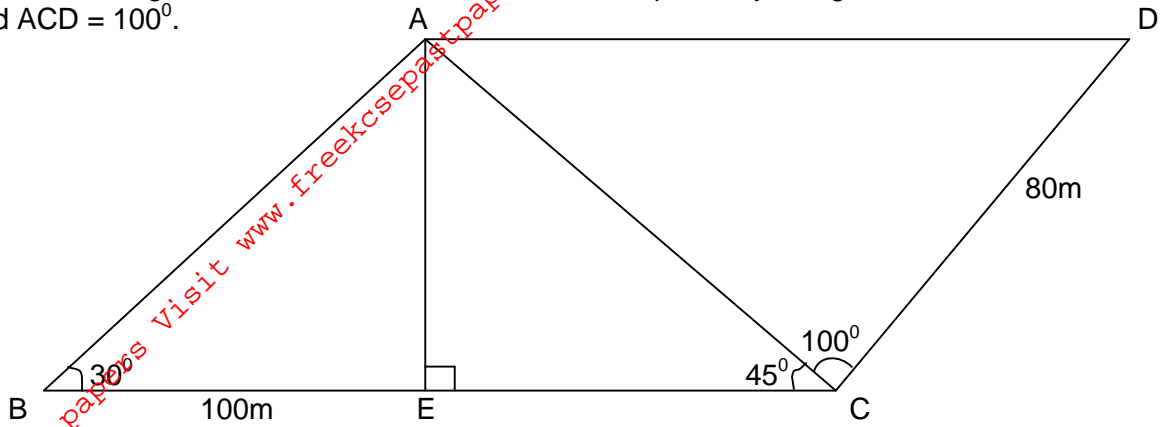

(a) Find to four significant figures:-

(i) The length of AE.

(2mks)

(ii) The length of AD.

(2mks)

(iii) The perimeter of the piece of land.

(3mks)

- (b) The plots are to be fenced with five strands of a barbed wire leaving an entrance of 2.8M wide to each plot. The type of barbed wire to be used is sold in rolls of lengths of 480M. Calculate the number of rolls of barbed wire that must be bought to complete the fencing of the plots. (3mks)