

THE KENYA NATIONAL EXAMINATIONS COUNCIL
Kenya Certificate of Secondary Education
Mathematics Paper 1
2006

SECTION I (50 marks)

Answer all the questions in this section.

Without using mathematical tables or a calculator evaluate

$$\frac{\sqrt[3]{675 \times 135}}{\sqrt{2025}}$$

(2 marks)

- 2 All prime numbers less than ten are arranged in descending order to form a number.

(a) Write down the number formed. (1 mark)

(b) State the total value of the second digit in the number formed in (a) above. (1 mark)

- 3 Simplify

$$\frac{p^2 + 2pq + q^2}{p^3 - pq^2 + p^2q - q^3}$$

(4 marks)

- 4 In the figure below, ABCDE is a regular pentagon and ABF is an equilateral triangle

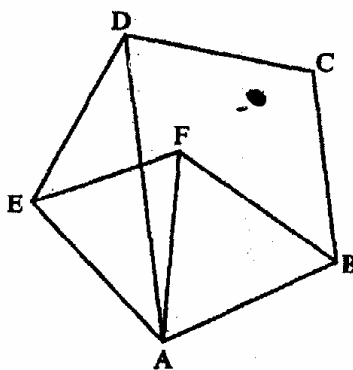

Find the size of

(a) $\angle ADE$

(1 mark)

(b) $\angle AEF$

(1 mark)

(c) $\angle DAF$

(1 mark)

5 Solve the inequality $3 - 2x < x \leq \frac{2x + 5}{3}$ and show the solution on the number line. (4 marks)

6 The length of a rectangle is $(3x + 1)$ cm. Its width is 3 cm shorter than its length. Given that the area of the rectangle is 28 cm^2 , find its length. (3 marks)

7 In this question, mathematical tables should not be used.

A Kenyan bank buys and sells foreign currencies as shown below:

	Buying (in Kenya shillings)	Selling (in Kenya shillings)
1 Hong Kong dollar	9.74	9.77
1 South African rand	12.03	12.11

A tourist arrived in Kenya with 105 000 Hong Kong dollars and changed the whole amount to Kenya shillings. While in Kenya, she spent sh 403 879 and changed the balance to South African rand before leaving for South Africa. Calculate the amount, in South African rand, that she received. (3 marks)

8 In this question use a pair of compasses and a ruler only.

(a) Construct triangle ABC such that $AB = 6 \text{ cm}$, $BC = 8 \text{ cm}$ and $\angle ABC = 135^\circ$. (2 marks)

(b) Construct the height of triangle ABC in (a) above, taking BC as the base. (1 mark)

9 A line with gradient of -3 passes through the points $(3, k)$ and $(k, 8)$. Find the value of k and hence express the equation of the line in the form $ax + by = c$, where a , b and c are constants. (3 marks)

10 Without using mathematical tables or a calculator evaluate

$$6 \log_2 \sqrt[3]{64} + 10 \log_3 \sqrt[3]{243} \quad (3 \text{ marks})$$

- 11 The diagram below represents a school gate with double shutters. The shutters are each opened through an angle of 63° .
The edges of the gate, PQ and RS are each 1.8 m.

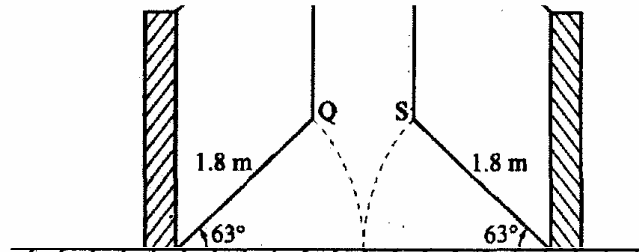

Calculate the shortest distance QS, correct to 4 significant figures. (3 marks)

- 12 Two points P and Q have coordinates $(-2, 3)$ and $(1, 3)$ respectively. A translation maps point P to $P'(10, 10)$.
- (a) Find the coordinates of Q' , the image of Q under the translation. (1 mark)
- (b) The position vectors of P and Q in (a) above are \mathbf{p} and \mathbf{q} respectively. Given that

$$m\mathbf{p} - n\mathbf{q} = \begin{pmatrix} -12 \\ \end{pmatrix}$$

find the values of m and n .

(3 marks)

- 13 The diagram below represents a right pyramid on a square base of side 3 cm. The slant edge of the pyramid is 4 cm.

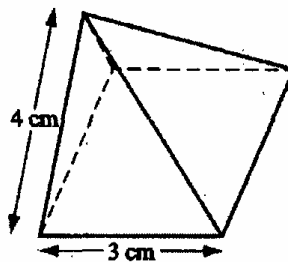

- (a) Draw a net of the pyramid. (2 marks)
- (b) On the net drawn, measure the height of a triangular face from the top of the pyramid. (1 mark)

- 14 Hadija and Kagendo bought the same types of pens and exercise books from the same shop. Hadija bought 2 pens and 3 exercise books for sh 78. Kagendo bought 3 pens and 4 exercise books for sh 108. Calculate the cost of each item. (3 marks)

- 15 The histogram below represents the distribution of marks obtained in a test. The bar marked A has a height of 3.2 units and a width of 5 units. The bar marked B has a height of 1.2 units and a width of 10 units.

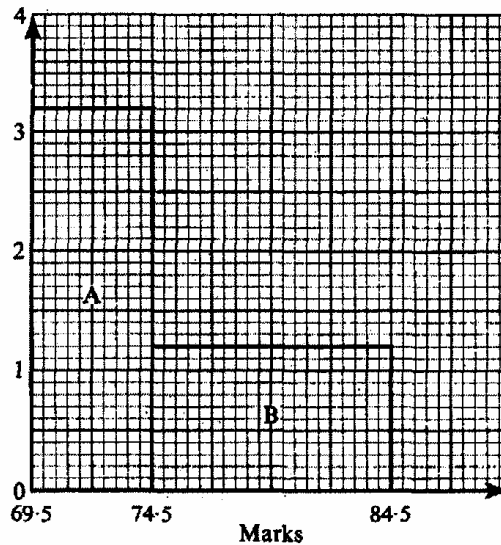

If the frequency of the class represented by bar B is 6, determine the frequency of the class represented by bar A. (3 marks)

- 16 A circle centre O, has the equation $x^2 + y^2 = 4$. The area of the circle in the first quadrant is divided into 5 vertical strips each of width 0.4 cm:
 (a) Use the equation of the circle to complete the table below for values of y correct to 2 decimal places. (1 mark)

x	0	0.4	0.8	1.2	1.6	2.0
y	2.00			1.60		0

- (b) Use the trapezium rule to estimate the area of the circle. (3 marks)

SECTION II (50 marks)

Answer any five questions in this section.

- 17 In the year 2001, the price of a sofa set in a shop was sh 12 000.
 (a) Calculate the amount of money received from the sales of 240 sofa sets that year. (2 marks)

- (b) (i) In the year 2002 the price of each sofa set increased by 25% while the number of sets sold decreased by 10%.

Calculate the percentage increase in the amount received from the sales. (3 marks)

- (ii) If at the end of year 2002, the price of each sofa set changed in the ratio 16:15, calculate the price of each sofa set in the year 2003. (1 mark)

- (c) The number of sofa sets sold in the year 2003 was $P\%$ less than the number sold in the year 2001.

Calculate the value of P , given that the amounts received from sales in the two years were equal. (4 marks)

- 18 On the cartesian plane below, triangle PQR has vertices $P(2,3)$, $Q(1,2)$ and $R(4,1)$ while triangle $P''Q''R''$ has vertices $P''(-2,3)$, $Q''(-1,2)$ and $R''(-4,1)$.

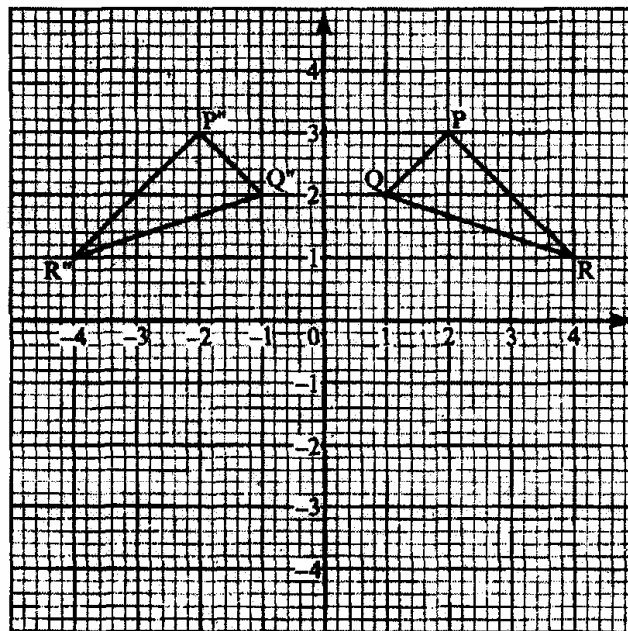

- (a) Describe fully a single transformation which maps triangle PQR onto triangle $P''Q''R''$. (2 marks)
- (b) On the same plane, draw triangle $P'Q'R'$, the image of triangle PQR , under reflection in line $y = -x$. (2 marks)
- (c) Describe fully a single transformation which maps triangle $P'Q'R'$ onto triangle $P''Q''R''$. (2 marks)
- (d) Draw triangle $P'''Q'''R'''$ such that it can be mapped onto triangle PQR by a positive quarter turn about $(0,0)$. (2 marks)
- (e) State all pairs of triangles that are oppositely congruent. (2 marks)

- 19 The diagram below (not drawn to scale) represents the cross-section of a solid prism of height 8.0 cm.

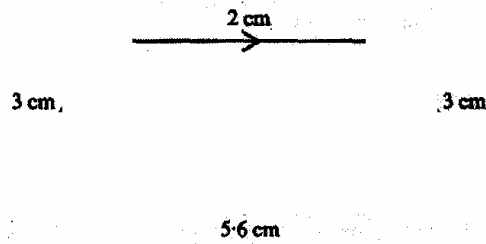

- (a) Calculate the volume of the prism. (3 marks)
- (b) Given that the density of the prism is 5.75 g/cm^3 , calculate its mass in grams. (2 marks)
- (c) A second prism is similar to the first one but is made of a different material. The volume of the second prism is 246.24 cm^3 .
- (i) Calculate the area of the cross-section of the second prism. (3 marks)
- (ii) Given that the ratio of the mass of the first prism to that of the second is 2:5, find the density of the second prism. (2 marks)
- 20 A bus left Mombasa and travelled towards Nairobi at an average speed of 60 km/h. After $2\frac{1}{2}$ hours, a car left Mombasa and travelled along the same road at an average speed of 100 km/h. If the distance between Mombasa and Nairobi is 500 km, determine
- (a) (i) the distance of the bus from Nairobi when the car took off. (2 marks)
- (ii) the distance the car travelled to catch up with the bus. (4 marks)
- (b) Immediately the car caught up with the bus, the car stopped for 25 minutes. Find the new average speed at which the car travelled in order to reach Nairobi at the same time as the bus. (4 marks)
- 21 The figure below represents a quadrilateral piece of land ABCD divided into three triangular plots. The lengths BE and CD are 100 m and 80 m respectively. Angle ABE = 30° , $\angle ACE = 45^\circ$ and $\angle ACD = 100^\circ$.

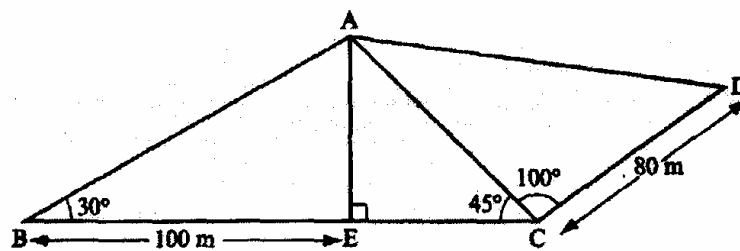

- (a) Find to four significant figures:
- (i) the length of AE (2 marks)
- (ii) the length of AD (3 marks)
- (iii) the perimeter of the piece of land. (3 marks)

- (b) The plots are to be fenced with five strands of barbed wire leaving an entrance of 2.8 m wide to each plot. The type of barbed wire to be used is sold in rolls of length 480 m. Calculate the number of rolls of barbed wire that must be bought to complete the fencing of the plots. (2 marks)

- 22 In the diagram below, the coordinates of points A and B are (1,6) and (15,6) respectively. Point N is on OB such that $3ON = 2OB$. Line OA is produced to L such that $OL = 3OA$.

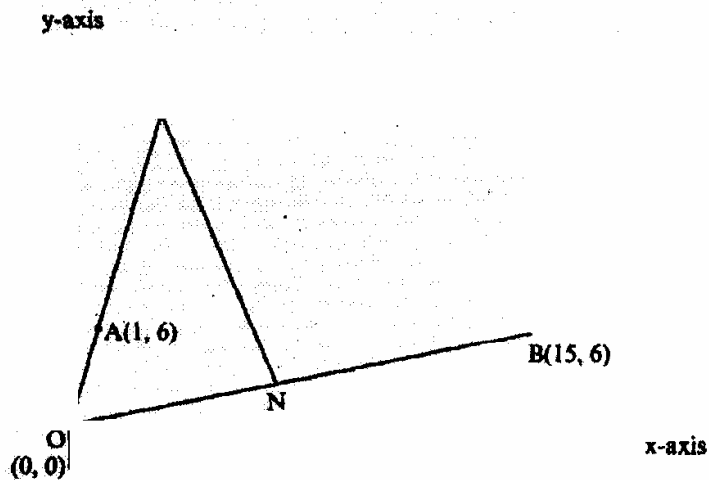

- (a) Find vector LN. (3 marks)
- (b) Given that a point M is on LN such that $LM:MN = 3:4$, find the coordinates of M. (2 marks)
- (c) If line OM is produced to T such that $OM:MT = 6:1$
- (i) Find the position vector of T. (1 mark)
- (ii) Show that points L, T and B are collinear. (4 marks)

- 23 The figure below is a model representing a storage container. The model whose total height is 15 cm is made up of a conical top, a hemispherical bottom and the middle part is cylindrical. The radius of the base of the cone and that of the hemisphere are each 3 cm. The height of the cylindrical part is 8 cm.

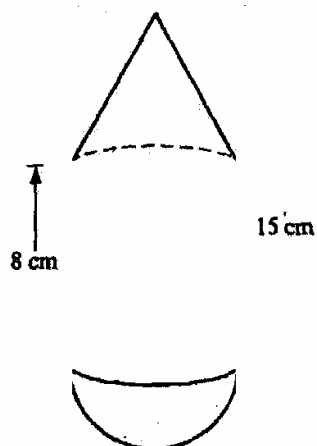

- (a) Calculate the external surface area of the model. (4 marks)

(b) The actual storage container has a total height of 6 metres. The outside of the actual storage container is to be painted. Calculate the amount of paint required if an area of 20 m^2 requires 0.75 litres of the paint. (6 marks)

24 A particle moves along a straight line such that its displacement S metres from a given point is $S = t^3 - 5t^2 + 3t + 4$ where t is time in seconds.

Find:

(a) the displacement of the particle at $t = 5$ (2 marks)

(b) the velocity of the particle when $t = 5$ (3 marks)

(c) the values of t when the particle is momentarily at rest (3 marks)

(d) the acceleration of the particle when $t = 2$. (2 marks)