

NAME.....INDEX NO.....

SCHOOL.....SIGNATURE.....DATE.....

232/3

PHYSICS

PAPER 3

PRACTICAL

JULY/AUGUST 2012

2½ HRS

KISUMU NORTH AND EAST DISTRICT JOINT TEST

Kenya Certificate of Secondary Education 2012

Instructions to candidates;

1. Write your name, index number and name of your school in the spaces provided.
2. This paper consists of two parts A and B.
3. Answer **all** questions in the spaces provided.
4. You are supposed spend the first 15minutes of the 2½ hours allowed for this paper reading the whole paper carefully before commencing your work.
5. Marks are given for a clear record of the observation actually, made, their suitability, accuracy and the use made of them.
6. Candidates are advised to record their observations as soon as they are made
7. Non-programmable silent electronic calculators and KNEC mathematical tables may be used.
8. The paper consists of **9** printed pages
9. Candidates should check the question paper to ascertain that all the pages are printed as indicated and that no questions are missing

For examiners use only

Question 1	a	c	e	f	g
Maximum score	3	7	5	4	1
Candidates score					
Total score					

Total

Total

Grand Total

Question 2	g	j	k
Maximum score	10	8	2
Candidates score			

QUESTION 1

1. You are provided with the following;
- A converging lens on a lens holder.
 - A screen fitted with cross-wires labeled O
 - A mounted white screen labeled S
 - A meter rule
 - Two dry cells
 - A mounted torch bulb
 - Connecting wires and switch
 - A retort stand boss and clamp

Proceed as follows;

- a) Find an approximate value of the focal length f of the converging lens supplied.

$f = \dots\dots\dots$ mm (1mk)

Explain briefly how the value of f was obtained (2mrks)

.....
.....
.....

- b) Arrange the apparatus as shown below

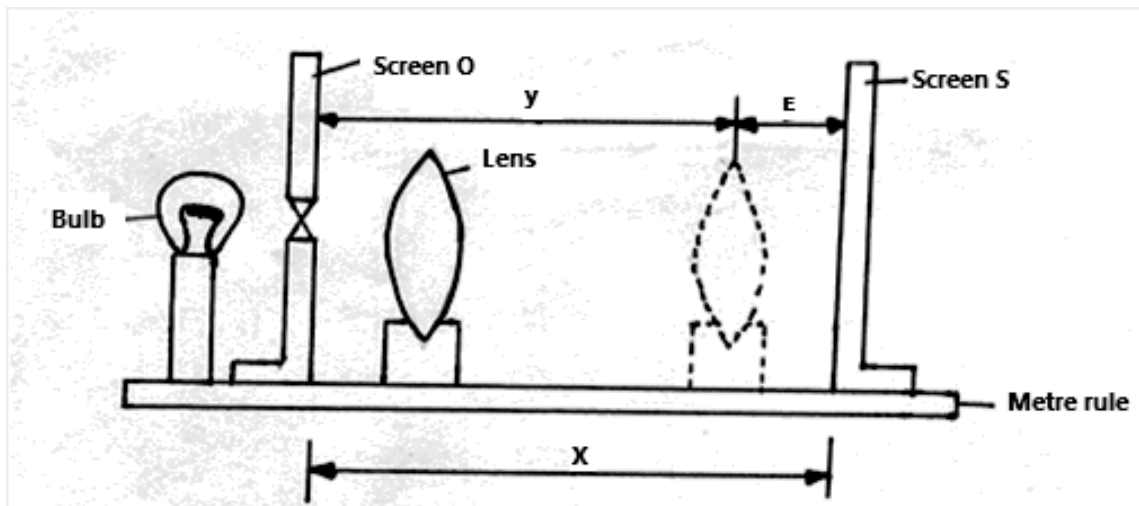

Set up the lens at a distance about $1.2f$ in front of the illuminated object. Adjust the position of the screen until a clear image is produced on the screen. Measure the distance X from the object to the screen. Record the value of X in table 1 below.

c) Move the lens nearer the screen until another clear image of the object is obtained. This image will be diminished. Measure the new distance Z between the lens and the screen and record the value in table 1 below.

Distance from object to lens (mm)	1.2f	1.3f	1.4f	1.5f	1.6f	1.7f	1.8f
	=	=	=	=	=	=	=
X(mm)							
z (mm)							
Y=(X- z) mm							
(y- z) ² (mm) ²							

(7marks)

d) Repeat the experiment to obtain new values of X, Y, z by moving the lens at various distances shown in the table above from the object and complete the table.

e) On the grid provided plot a graph of (X- z)² (y-axis) against X starting the scale of X at 350mm (5marks)

f) From the graph find the value of

i. X when (X- z)²=0 (2marks)

.....

.....

.....

.....

ii. (y - z)² when X =5f (2marks)

.....

.....

.....

.....

g) Use these values of (X- z)² and X to calculate the value of ; (1mark)

$$\frac{4(X - z)^2}{X}$$

.....

.....

GRid

For More Free KCSE past papers visit www.freekcsepastpapers.com

QUESTION 2

2. You are provided with the following;

- A retort stand, boss and clamp.
- Test tube
- Piece of duplicating paper
- A thermometer
- A large beaker containing some water
- A tripod stand and wire gauze
- A cardboard with a hole in the middle
- A burner
- A rubber band
- A stop band
- A stop watch

Proceed as follows;

a) Set up the apparatus as shown below.

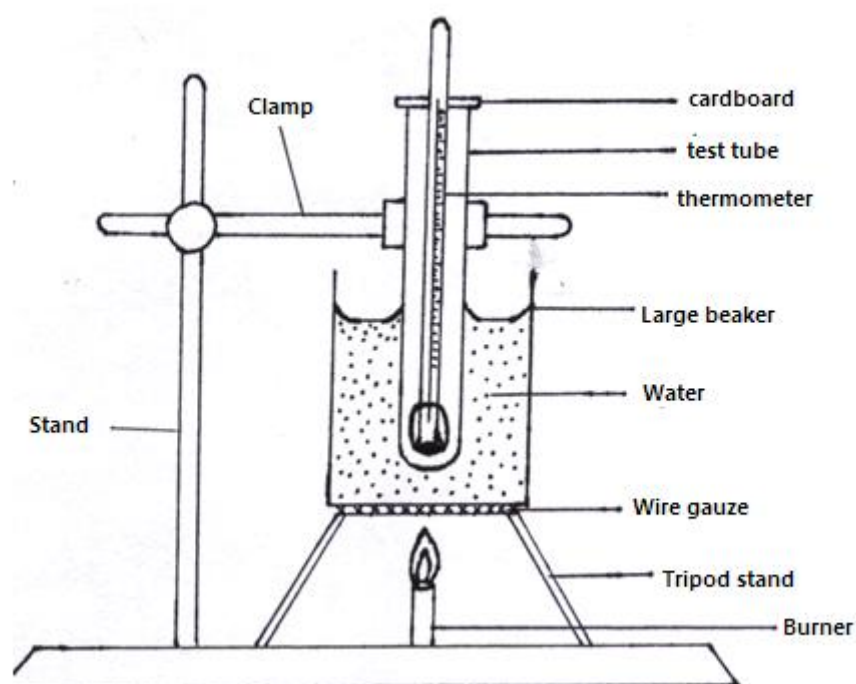

- b) Heat the water in the beaker provided and leave it to boil
- c) Wrap the given piece of duplicating paper round the bulb of the thermometer. Use rubber band to hold the paper in place.
- d) Place the thermometer inside in the dry test tube.

- e) Place the test tube in the water as shown in the diagram above. Make sure that the water does not enter the test tube. Leave the test tube in the boiling water until the thermometer indicates a steady temperature.
- f) Remove the thermometer and immediately start the stop watch.
- g) While holding the thermometer in air record the readings of the thermometer T_1 at intervals of 30seconds for 10 minutes.

Time in minutes	0	0.5	1.0	2.0	2.5	3.0	3.5	4.0	4.5	5.0	5.5
T_1 ($^{\circ}\text{C}$)											
T_2 ($^{\circ}\text{C}$)											

Time in Minutes	6.0	6.5	7.0	8.0	8.5	9.0	9.5	10.0
T_1 ($^{\circ}\text{C}$)								
T_2 ($^{\circ}\text{C}$)								

(10mrks)

- h) Place the wrapped thermometer directly into boiling water. Leave the thermometer in the boiling water until it indicates a steady temperature.
- i) Repeat procedure (f) and (g) and record the reading T_2 of the thermometer in the table at half minute intervals for 5minutes.
- j) Using the same axes on the grid provided, plot a graph of temperature (y-axis) against time for result obtained in (g) and (i) (label the graph T_1 and T_2)

(8mrks)

k) From the graphs determine;

- i. For each graph the time for temperature to fall from 60°C to 40°C . (1mrk)

.....

- ii. Find the ratio of the two times in k (i) above (1mrk)

.....

For More Free KCSE past papers visit www.freekcsepastpapers.com

Grid

For More Free KCSE past papers visit www.freekcsepastpapers.com