

Name..... Index No.....

School..... Date.....

Candidate's signature.....

121/1
MATHEMATICS
PAPER 1
JULY / AUGUST 2012
TIME: 2 ½ HOURS

LOITOKITOK DISTRICT JOINT EVALUATION TEST – 2012
Kenya Certificate of Secondary Education (K C.S.E.)

INSTRUCTIONS TO THE CANDIDATES:

1. Write your name and Index number in the spaces provided at the top of this page.
2. This paper consists of two sections: **Section I and Section II.**
3. Answer all questions in section **I and Section II**
4. Show all the steps in your calculations, giving your answers at each stage in the spaces below each question.
5. Marks may be given for correct working even if the answer is wrong.
6. Non- programmable silent electronic calculators **and KNEC** Mathematical tables may be used.

For Examiners' Use Only

SECTION I

<i>1</i>	<i>2</i>	<i>3</i>	<i>4</i>	<i>5</i>	<i>6</i>	<i>7</i>	<i>8</i>	<i>9</i>	<i>10</i>	<i>11</i>	<i>12</i>	<i>13</i>	<i>14</i>	<i>15</i>	<i>16</i>

SECTION II

<i>17</i>	<i>18</i>	<i>19</i>	<i>20</i>	<i>21</i>	<i>22</i>	<i>23</i>	<i>24</i>

TOTAL

This paper consists of 16 Printed pages.

Candidates should check to ascertain that all pages are printed as indicated and that no questions are missing.

SECTION 1 (50 MARKS)

Answer all the question in this section on the spaces below each Question:

1. Determine the value of subtracting the reciprocal of $\frac{2}{3} - \frac{1}{2}$ of $\frac{3}{4} + 1 \times \left[\frac{5}{7} + \frac{3}{4} \right]$ from 1 (3marks)

2. Solve the equation $15 + 4a - \left[\frac{3a \div 6}{8} - \frac{a + 5}{4} \right] = 0$ (3marks)

3. Find y if $\log_2 y - 2 = \log_2 92$ (3 marks)

4. A square whose vertices are P (1, 1), Q (2, 1), R (2, 2) and S (1, 2) given an enlargement with centre at (0, 0). Find the images of the vertices if the scale factor is 3: (2 marks)

5. The line passing through the point $C(1,3t)$ and $D(t,3)$ is parallel to the line whose equation is $2y - 3x = 9$. Write down the coordinates of C and D. (3mks)

6. In the figure below, ABCD is a cyclic quadrilateral and BD is a diagonal. EADF is a straight line. $\angle CDF = 68^\circ$, $\angle BDC = 45^\circ$ and $\angle BAE = 98^\circ$.

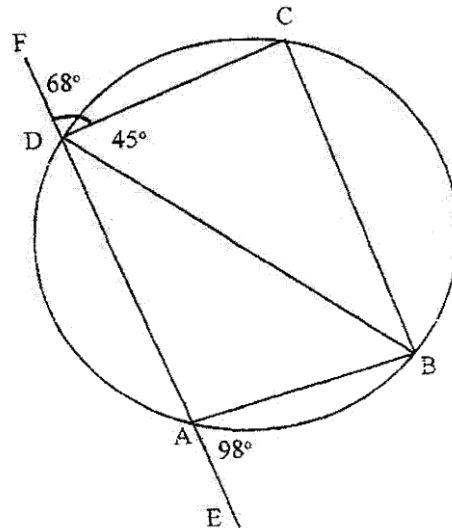

- Calculate the size of
- (a) $\angle ABD$ (2 marks)
- (b) $\angle CBD$ (2 marks)

7. Under a transformation whose matrix is $T = \begin{bmatrix} a-2 & -2 \\ a & a \end{bmatrix}$ a figure whose area is 2.5 cm is mapped onto a figure whose area is 10 cm². Find two possible values of a and hence write down two possible matrices. (4marks)

8. A bus travelling at an average speed of 63 km/h left the station at 8:15 am. A car left the same station at 9:00 am and caught up with the bus at 10:45 am. Find the average speed of the car (3 marks)

9. Given that the equation of the normal to the curve $y = x^2 + 3x + 5$ at point C is $5y + x = 46$ find the coordinates of C. (3marks)

10. Machine A can do a piece of work in 6 hours while machine B can do the same work in 9 hours. Machine A was set to do the piece of work but after 3 5hours, it broke down and machine B did the rest of the work. Find how long machine B took to do the rest of the work. (3marks)

11. Simplify the expression $\frac{12x^2 + ax - 6a^2}{9x^2 - 4a^2}$ (3 marks)

12. A student at a certain college has a 60% chance of passing an examination at the first attempt. Each time a student fails and repeats the examination his chances of passing are increased by 15% Calculate the probability that a student in the college passes an examination at the second or at the third attempt. (4marks)

13. Water and milk are mixed such that the ratio of the volume of water to that of milk are 4:1. Taking the density of water as 1 g/cm^3 and that of milk as 1.2 g/cm^3 , find the mass in grams of 2.5 liters of the mixture. (3 marks)

14. Every week the number of absentees in a school was recorded. This was done for 39 weeks these observations were tabulated as shown below.

Number of absentees	0 -3	4-7	8 -11	12 – 15	16 – 19	20 - 23
(Number of weeks)	6	9	8	11	3	2

Estimate the median absentee rate per week in the school (3mks)

15. In the diagram below, determine vector \vec{OW} in terms of \mathbf{i} , \mathbf{j} and \mathbf{k} . Given that W divides AB in the ratio $2:3$. (3marks)

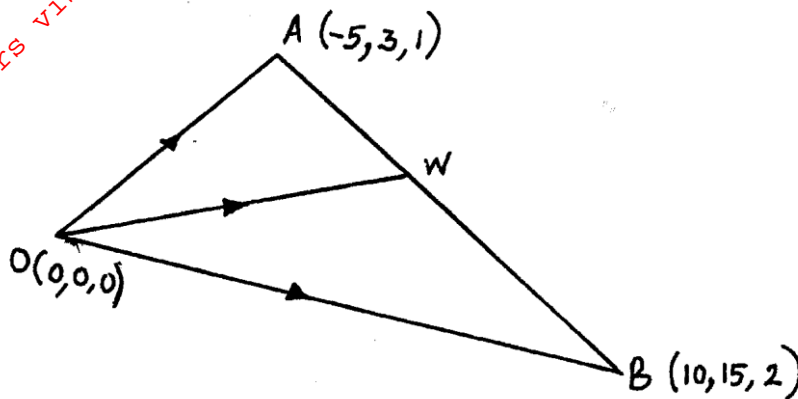

16. Form a quadratic equation in t whose roots are -4 and 7 . (3marks)

SECTION 11 (50 MARKS)

Answer any FIVE questions from this section

17. A slaughter house bought a number of sheep at sh 1200 each and a number of oxen at sh 15000 each. They paid a total amount of sh 135,000. If they had bought twice as many sheep and three oxen less they would have saved sh 15000.
- a) Find the number of each type of animals they bought. (6marks)
- b) The slaughter house sold all the animals at a profit of 30% per sheep and 35% per oxen. Determine the total profit they made. (4marks)

18. The figure below represents a frustum of a solid cone of base radius 48 cm and top radius 16 cm. The height of the frustum is 21 cm. (Taking $\pi = \frac{22}{7}$ calculate:

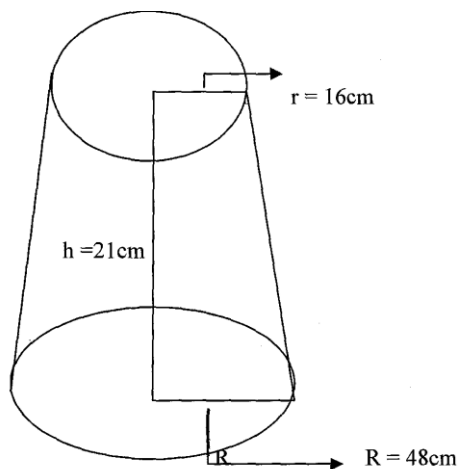

a) The height of the solid cone (2marks)

b) The volume of the solid frustum (3marks)

c) The total surface area of the frustum (5marks)

19. The 2nd 7th and 22nd terms of an arithmetic progression are the first three consecutive terms of a geometric progression. The 10th term of the arithmetic progression is 21 Determine:
- a) The first term and the common difference of the A.P (6 marks)

- b) The sum of the first six terms of the G.P (4 marks)

20. The figure below represents a rectangle PQRS inscribed in a circle centre O and radius 17cm. PQ 16cm.

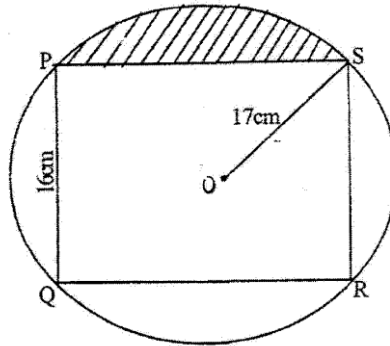

Calculate:

- (a) The length PS of the rectangle (2marks)

- (b) The angle POS (3marks)

- (c) The area of the shaded region (5marks)

21. a) On the grid provided draw the quadrilateral $p(1, 0)$, $Q(4, 0)$, $R(4, 2)$, and $S(1, 2)$ and its image $P^1Q^1R^1S^1$ under the transformation whose matrix is $\begin{pmatrix} -1 & 0 \\ 0 & 2 \end{pmatrix}$ (3marks)

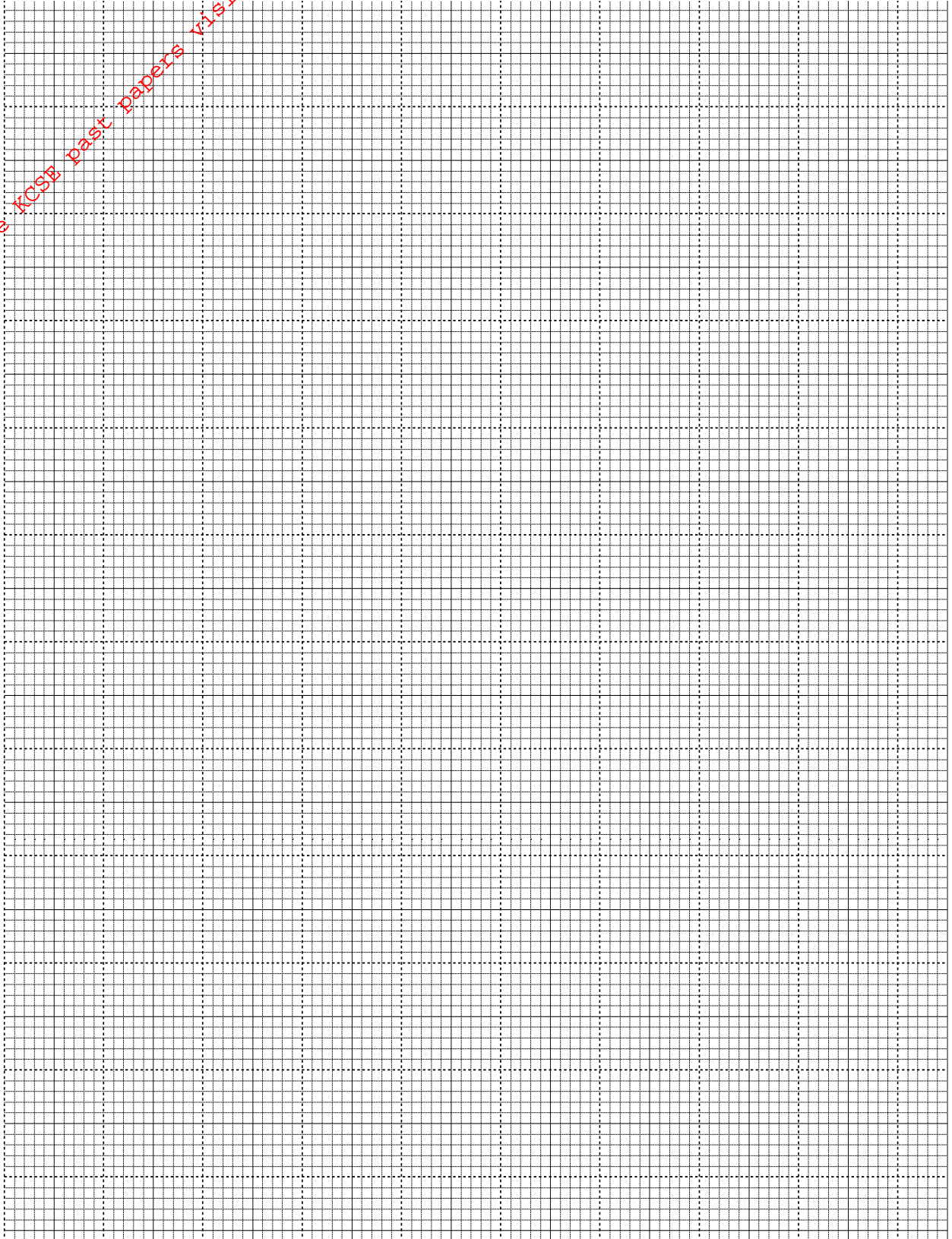

- b) Describe the transformation represented by the matrix in (a) above (2marks)

- c) Find the image of P'Q'R'S' under the transformation whose matrix is $\begin{pmatrix} -1 & 0 \\ 0 & 1 \end{pmatrix}$ and label the image of the figure as P''Q''R''S''. Draw P''Q''R''S'' on the same grid as (a) above. (3marks)

- d) Determine single matrix of transformation which maps on to P¹¹Q¹¹R¹¹S¹¹ onto PQRS (2marks)

22. A pilot fly from P to S through Q and R he distance of Q from P is 820 km on a bearing of 055° . R is 600km on bearing of 030° from Q while S is on a bearing of 240° a distance of a 1000km from R.

a) Using a suitable scale draw a diagram representing the routes of the flight (4marks)

b) On the return journey the pilot flew directly from S to P .What was his direction of flight. (1marks)

c) How long did the flight in (b) above take If the pilot travelled at 650km/h? (2marks)

d) If on reaching S the pilot decided to fly directly to Q what would have been his direction of flight and time taken if he flew at 700km/h? (3marks)

23. During the year 2001 Samora had 40 more goats than sheep and half as many cows as sheep. In the year 2002 his goats increased by 50%, his cows decreased by 10% and his sheep increased by 20%. At the end of 2002 all his animals were 690. Calculate to the nearest whole number the percentage increase in the number of animals during the year 2002. (10marks)

24. The table below shows the values of x and some values of y for the curve $y = x^3 + 3x^2 - 4x - 12$ in the range $-4 \leq x \leq 2$

a) Complete the table by filling in the missing values of y (2marks)

X	-4	-3.5	-3	-2.5	-2.0	-1.5	-1.0	-0.5	0	0.5	1.0	1.5	2.0
Y		-4.1		-1.1		-2.6		-9.4		-13.1		-7.9	

b) On the grid provided draw the graph of $y = x^3 + 3x^2 - 4x - 12$ in the range $-4 \leq x \leq 2$ (4marks)

c) By drawing a suitable straight line on the same grid solve the equation $x^3 + 3x^2 - 5x - 6 = 0$ (4marks)

