

3.20 ELECTRICITY (448)

3.20.1 Electricity Paper 1 (448/1)

SECTION A (48 marks)

Answer **all** the questions in this section.

- 1 (a) List the **three** classes of materials according to their electrical conductivity and for each class give **one** example. (3 marks)
- (b) State the meaning of the term career. (1 mark)
- 2 (a) List **four** characteristics of an entrepreneur. (2 marks)
- (b) For each of the following activities, state **one** safety precaution to be taken when: (2 marks)
- (i) removing a 470 $\mu\text{F}/240\text{V}$ capacitor from a television set circuit during repair;
 - (ii) handling rotating parts of electrical machines.
- 3 With the aid of graphical symbols, describe the difference between a potentiometer and a Rheostat. (5 marks)
- 4 The average daily power consumption of a domestic consumer is as follows:
- Lighting 0.5kw for 6 hours
 - Water heating 3.0kw for 2 hours
 - Cooking 5.0kw for 2 hours
 - Other appliances 3.5kw for 3 hours
- (a) Determine the daily consumption in kWh. (3 marks)
- (b) If the monthly standing charge is Ksh.100.00, calculate the bill for a month of 30 days. (3 marks)
- 5 (a) State **four** factors that determine the strength of an electromagnet. (2 marks)
- (b) **Figure 1**, shows the direction of force on a current carrying conductor in a magnetic field. Sketch the magnetic flux lines to create the force. (2 marks)

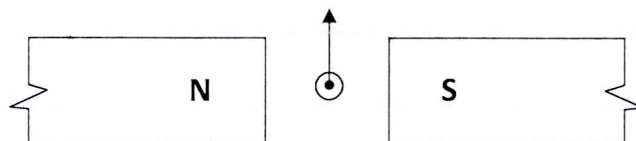

Figure 1

6

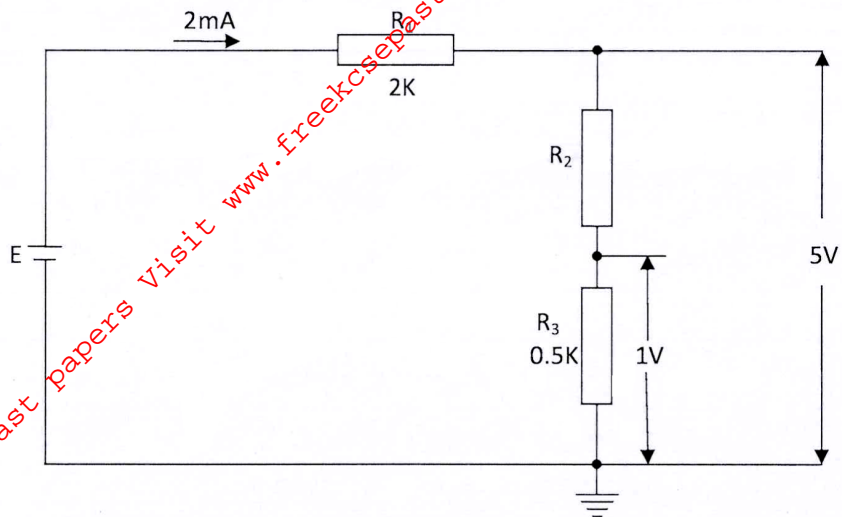

Figure 2

From the circuit shown in **figure 2** calculate the values of: (3 marks)

- (a) E
- (b) R_2

7 (a) Name **four** accessories used in domestic lighting installation. (2 marks)

(b) State **one** difference between MIMS and PVC sheathed cables. (2 marks)

8 (a) Name **two** types of D.C generators. (1 mark)

(b) With the aid of a diagram, describe the operation of a simple A.C. generator. (5 marks)

9 (a) Perform each of the following number conversions. (2 marks)

(i) 101101_2 to decimal

(ii) 46_{10} to binary

(b) **Figure 3**, shows a symbol of a logic gate.

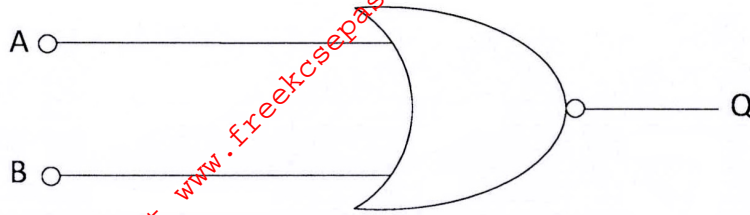

Figure 3

(i) Name the gate.

(1 mark)

(ii) Draw and complete the truth table for output Q of the logic gate.

(2 marks)

(c) **Figure 4**, shows a basic regulator circuit.

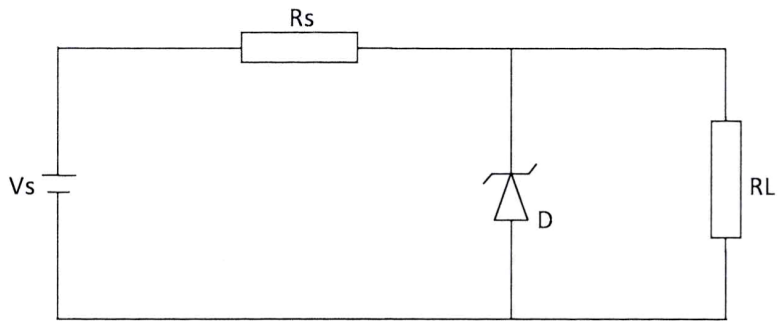

Figure 4

State the effect on voltage across R_L when:

(2 marks)

(i) Zener diode is shorted.

(ii) Zener diode open.

10 **Figure 5**, shows orthographic views of a block drawn in first angle projection.

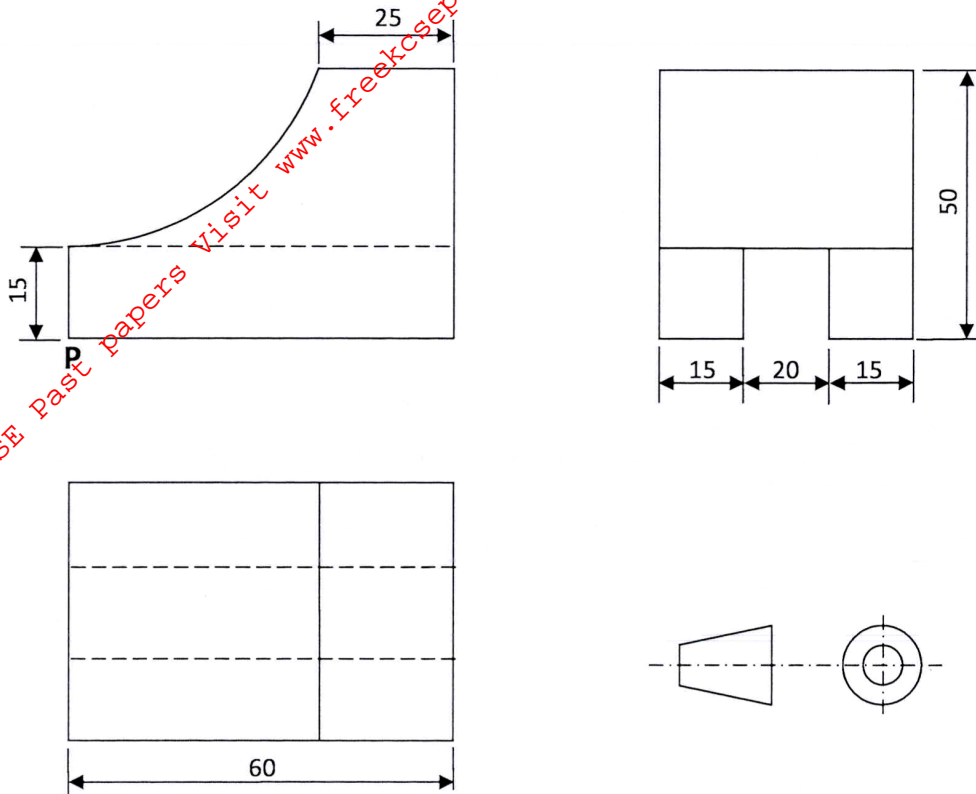

Figure 5

On the isometric grid paper provided, draw the block in isometric projection with P as the lowest point.

(5 marks)

SECTION B (52 marks)

Answer any **four** questions from this section, in the spaces provided.

11 (a) With reference to Sinusoidal waveforms, explain each of the following terms: (3 marks)

- (i) Amplitude;
- (ii) Period;
- (iii) Frequency.

(b) A Sinusoidal voltage trace displayed on an oscilloscope has peak to peak voltage of 24 V and a period of 40 ms. Draw the waveform and calculate: (10 marks)

- (i) Frequency;
- (ii) Average value;
- (iii) RMS value.

12 (a) With the aid of a labelled diagram, explain the operation of a split-phase AC motor. (8 marks)

(b) An ideal transformer is used to step down 480 V to 240 V. The 240 V output is connected to a 24 KW resistive load. Determine the: (5 marks)

- (i) load current;
- (ii) input current;
- (iii) transformer ratio.

13 (a) Draw a wiring diagram of a final circuit of one lamp controlled from **three** different points. (4 marks)

(b) With the aid of a labelled diagram, explain the operation of a switch start fluorescent lamp. (9 marks)

14 (a) Describe each of the following processes of making a permanent magnet: (4 marks)

- (i) heating;
- (ii) stroking.

(b) With the aid of a labelled diagram, explain how a relay operates a high current load. (9 marks)

15 (a) Draw and label a schematic symbol for each of the following **two** input logic gates. (3 marks)

- (i) OR
- (ii) NAND

(b) Construct a truth table for a **two** input NAND gate. (4 marks)

(c) An electric kettle suddenly stops heating water yet there is power in the socket outlet. Outline the procedure for identifying the possible faults using an ohmmeter. (6 marks)

3.20.2 Electricity Paper 2 (448/2)

1 EXERCISE 1

Use the circuit, equipment and component provided to perform the following tasks.

- Connect the resistor labelled A across point X and Y of the circuit.
- Set the stopwatch to zero.
- Press switch S until voltage reading settles at about 10V.
- Release push button switch S and time the duration it takes for the voltage to drop to about 3-7 V and record the time in **Table 1**.

Table 1

Resistor	A	B	C	D	E
Time (s)					

- Repeat tasks (a) to (d) for each of the resistors B, C, D and E. (12 marks)
- Use schematic symbols to draw the circuit and label the components. (6 marks)
- From the results obtained, calculate the value of resistor labelled E. (2 marks)

2 EXERCISE 2

Using the materials, tools and equipment provided, fabricate the candle stand shown in figure 1. Its dimensions are given in the layout. (20 marks)

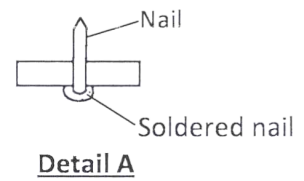
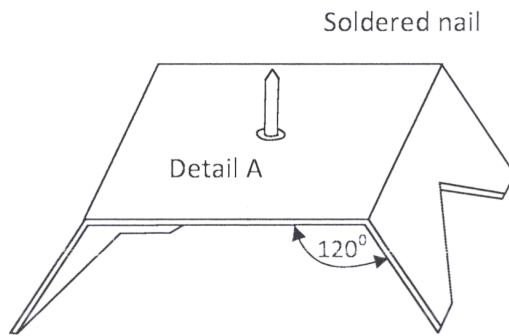
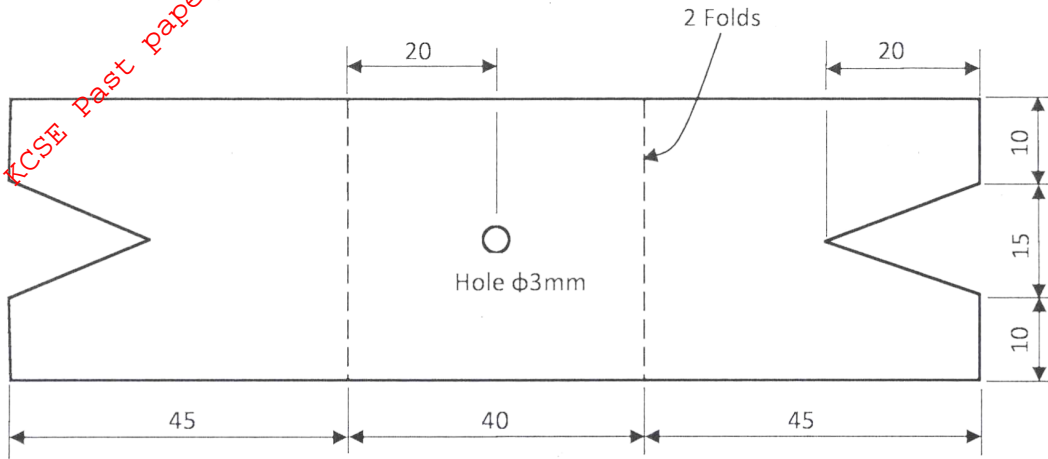

Figure 1

3 EXERCISE 3

Using the components, materials and equipment provided, perform the following tasks.

- (a) Connect the circuit shown in **figure 2** and let the examiner check your work.

(6 marks)

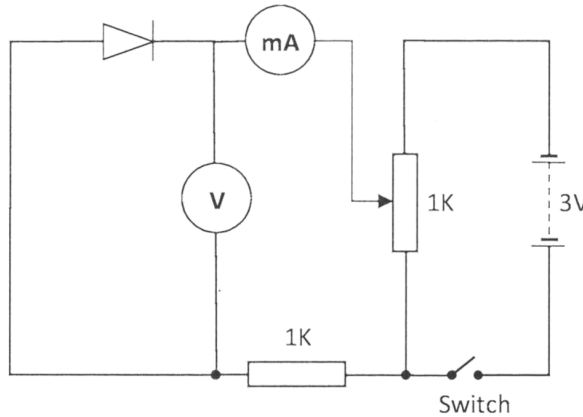

Figure 2

- (b) Close the switch. Adjust the potentiometer to obtain voltage reading shown in **Table 2**. For each voltage obtained, measure and record the corresponding current values.

(5 marks)

Table 2

Voltage (V)	0	0.5	0.7	0.9	1.3	1.7
Current (mA)						

- (c) Plot a graph of current against voltage. (6 marks)

- (d) From the graph:

(i) determine the resistance when the voltage is 1.3 V;

(ii) give a reason for the shape of the graph.

(3 marks)

4 EXERCISE 4

Using the pre-fabricated circuit provided in figure 3, perform the following tasks:-

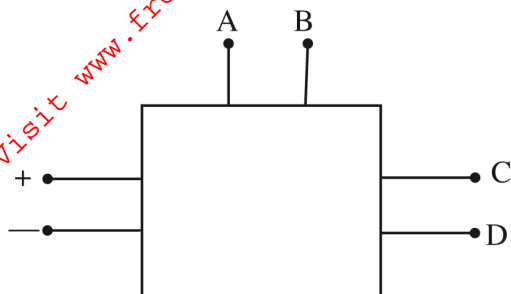

Figure 3

(a) With the switch open:

- (i) connect the milliammeter between **A** and **B**.
(observe the polarity).
- (ii) connect the voltmeter between **C** and **D**.
(observe the polarity).

(2 marks)

(Let the examiner check your work)

(b) Close the switch

Adjust the variable resistor to obtain the current values in Table 3 and in each case measure and record the corresponding voltage values.

(10 marks)

Table 3

Current (mA)	2	4	6	8	10
Voltage (V)					

(c) (i) Plot the graph of current against voltage.

(ii) Use the graph to determine the value of current when the voltage is 5.5 V.

(8 marks)

5 EXERCISE 5

Figure 4 shows a lighting circuit. Using materials, tools and equipment provided, instal the circuit such that the switch controls the lamp. (20 marks)

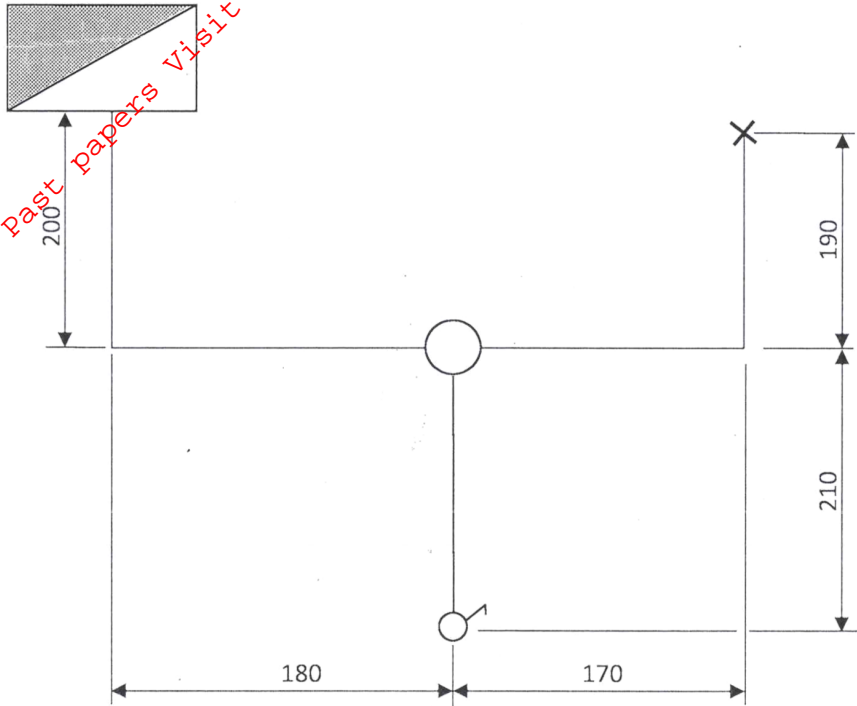

Fig. 4