

### 3.17 METALWORK (445)

#### 3.17.1 Metalwork Paper 1 (445/1)

#### SECTION A (40 marks)

Answer **ALL** questions in this section in the spaces provided.

- 1 (a) Outline a problem that is likely to occur as a result of:
- (i) scribing a line using a dot punch; (1 mark)
  - (ii) dot punching using a scriber.. (1 mark)
- (b) Outline **three** methods of extracting a broken tap from a hole. (3 marks)
- 2 (a) State **two** uses of a template. (2 marks)
- (b) With the aid of a sketch outline the procedure of locating the centre of a round bar using an oddleg callipers. (2 marks)
- (c) With reference to finishing of metal surfaces:-
- (i) state **two** reasons for painting; (1 mark)
  - (ii) list **two** methods of applying paint. (1 mark)
- 3 (a) List **two** uses of a drift in forging. (1 mark)
- (b) State **two** precautions to be observed when twisting a metal bar to avoid uneven twist. (1 mark)
- 4 (a) Give **two** reasons for using hollow metals in making furniture. (1 mark)
- (b) State **four** safety precautions to observe when using a grinding machine. (2 marks)
- 5 (a) List **four** specifications to consider when buying a rivet. (2 marks)
- (b) State **three** factors to consider when selecting spelter for brazing. (3 marks)
- 6 (a) List **four** methods of holding a work piece on a lathe machine. (2 marks)
- (b) State **two** reasons for knurling. (1 mark)

- 7 (a) Outline **three** functions of an electrode flux during the arc welding process. (3 marks)
- (b) List **two** broad uses of metals. (1 mark)
8. (a) List **four** sources of information related to career choice in a school setting. (2 marks)
- (b) A metal work company is to be established in a new premises. Outline **four** considerations to be taken into account during this process. (2 marks)
- 9 (a) Explain the purpose of annealing metals. (1 mark)
- (b) Outline the annealing process. (2 marks)
- 10 (a) Use sketches to show:
- (i) a double hem edge; (1 mark)
- (ii) a false wire edge. (1 mark)
- (b) State **one** resulting property of alloying steel with each of the following elements:-
- (i) Manganese
- (ii) Chromium
- (iii) Nickel (3 marks)

SECTION B (60 marks)

Answer question **11** and any other **three** questions in the spaces provided.

Candidates are advised to spend **NOT MORE THAN 25 MINUTES** on question **11**.

**11** Figure 1 shows orthographic views of a machined block drawn in first angle projection.

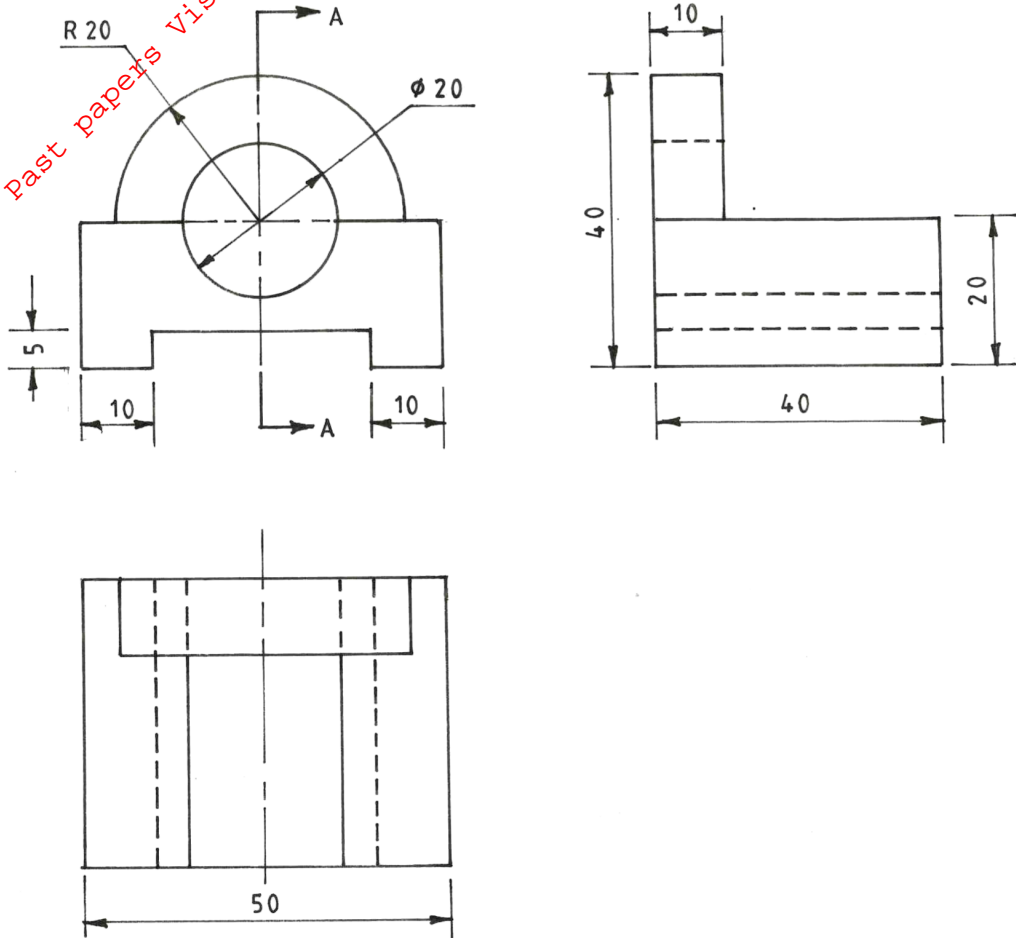

Fig. 1

Draw full size, the following;

- (a) the oblique view of the block; (10 marks)
- (b) the sectional end elevation through A-A. (5 marks)

**12** (a) With reference to brazing outline:-

- (i) **four** points to consider in order to obtain a strong brazed joint; (4 marks)
- (ii) **four** safety precautions to be observed while brazing. (2 marks)

(b) With respect to arc welding:-

(i) state **three** points to consider when selecting an electrode; (1½ marks)

(ii) Name and illustrate **two** methods of starting an arc. (6 marks)

(iii) List **three** methods of inspecting the quality of a weld. (1½ marks)

13 With the aid of labelled sketches, outline the following lathe procedures:

(a) Drilling (8 marks)

(b) Parting off (7 marks)

14 Figure 2 shows an iron box stand made of mild steel plate.

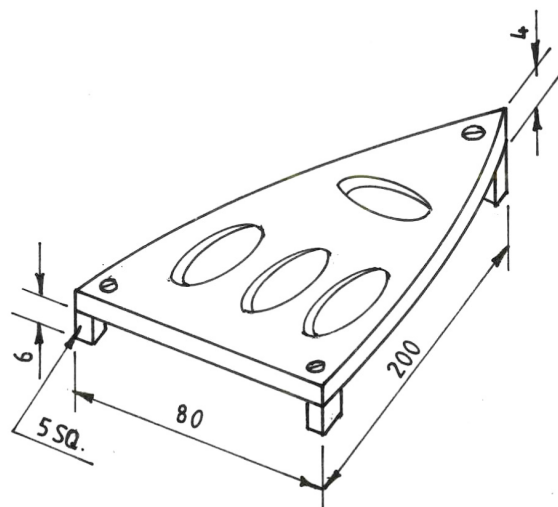

Fig. 2

(a) Prepare a cutting list for the stand. (3 marks)

(b) Outline the procedure of:-

(i) making the stand; (9 marks)

(ii) case hardening the stand. (2 marks)

(c) Name **two** appropriate methods of finishing the stand. (1 mark)

15 (a) With the aid of sketches outline the procedure of making a grooved seam. (6 marks)

(b) Outline the procedure of soldering a grooved seam. (6 marks)

(c) Give **two** examples where a grooved soldered seam is used. (1 mark)

(d) Outline the procedure of cutting a 100 mm diameter hole on a sheet metal using curved snips. (2 marks)