

INTRODUCTION TO AGRICULTURE

K.C.S.E PAST PAPERS

1. 1996: What is plantation farming system?
2. 1997: State the main characteristics of shifting cultivation.
3. 1997: Differentiate between olericulture and pomoculture
4. 1997: State three characteristics of shifting cultivation.
5. 2001: State six reasons why agriculture is important in Kenya's economy
6. 2002: State two ways in which agriculture contributes directly to the development of industries.
7. 2004: Give the limitations of pastoral Farming.
8. 2004: State any two disadvantages of pastoral nomadism system of farming.

FACTORS INFLUENCING AGRICULTURE

K.C.S.E PAST PAPERS

1. 1995: List four environmental factors that affect crop distribution in Kenya.
2. 1996: State two ways by which wind affects the growth of crops.
3. 1997:
 - a) State two ways by which wind affects the growth of crops.
 - b) Give two roles of micro-organisms in the soil that are beneficial to crops
 - c) State three properties of soil that are influenced by its texture.
4. 1999: List down the four aspects of rainfall that affect agriculture.
5. 1999: Describe the environmental conditions that may lead to low crop yields.
6. 2000: Outline three effects of soil organisms which benefit crop growth.
7. 2001: State two causes of hard pan in a crop yield.
8. 2002:
 - a) Name two processes of rock weathering.
 - b) Differentiate between soil texture and soil structure.
 - c) State three benefits of good soil structure in crop production.
9. 2003:
 - a) List two aspects of light that influence crop growth.
 - b) The diagram below shows an experiment set up using soil types G, H and J and observations made after 24 hours. Study the diagram and answer the questions that follow.

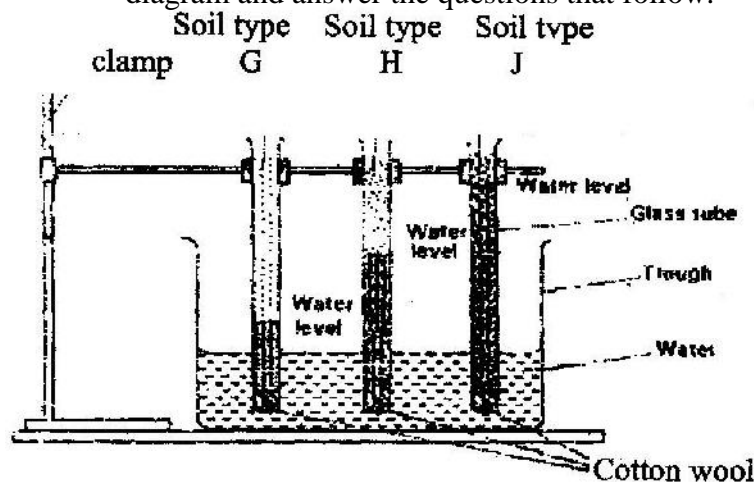

- i) What is the experiment represented above designed to study?
- ii) Name the three soil types G, H and J.
- iii) What is the characteristic texture of soil types G and J?
- iv) State how a farmer would improve the structure of soil type G.

10. 2004: a) Give 3 reasons why soil is important to crops.
 b) State two benefits of optimum soil temperature in crop production.
 c) Give 3 factors of soil that influence soil productivity.
11. 2004: Give three reasons why soil is important to crops.
12. 2004: a) Give four reasons why a well drained soil is suitable for crop production.
 b) State two benefits of optimum soil temperature in crop production.
 c) Give three soil factors that influence soil productivity.
13. 2005: State three advantages of adding organic matter to sandy soil.
14. 2005: a) State two roles of good soil aeration in crop growth.
 b) Give two roles of micro-organisms in the soil that are beneficial to crops.
 c) State three properties of soil that are influenced by its texture.

FARM TOOLS AND MACHINERY

1. 1995: Give one use of each of the following hammers;
 i) Ball pein hammer ii) Sledge hammer
 State two maintenance practices that should be carried out on a wheelbarrow.
2. 1996 The diagram labeled N I, N II, N III below represent some tools used in farms.



N I-----

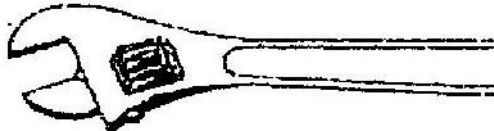

N II



N III

- i) What functional advantage does the tool labeled N II have over the tool labeled N III?
 ii) What is the function of tool labeled N I iii) Give the maintenance practice of N I
3. Study the photographs below carefully and answer the questions that follows:



- a) i) Identify 1-----
2-----
- ii) Give the land preparation stage when 2 is used
- b) i) Which of the tools is suited for a field with roots, trash and other obstacles?
- ii) Give a reason for your answer in b(i)
4. 1996: State one use of each of the following tools;
(i) Spoke shave (ii) Plumb bob
5. 1997: Name two tools used for cutting galvanized iron pipes.
6. 1998: State four maintenance requirements of a jack plane.
7. 1998: List four tools used for laying concrete blocks when constructing a wall.
8. 1999: a) What is the difference between a tenon saw and a crosscut saw?
b) What safety measure should be taken when using a crosscut saw?
c) Give three maintenance practices that should be carried out on crosscut saws.
9. 2000: Give the factor, that are considered when selecting a garden tool for primary cultivation.
- 10: 2000 (a) State one use of each of the following tools, (i) sickle
ii) Secateurs.
- b) Give two reasons for proper maintenance of farm implements.
- c) State three factors that should be considered when selecting gardener tools for primary cultivation.
12. 2001: L, M, N and O are diagrams of farm tools. Study them and answer the questions that follow.

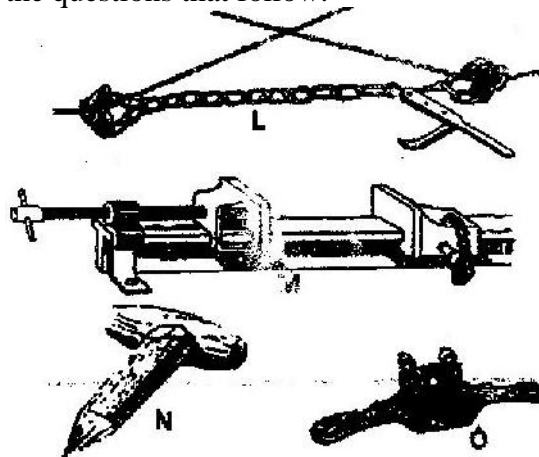

- i) Identify the farm tools; L, AA>N and O. (ii) State the use of each tool L, AA, N and O.
13. 2001: List the tool used for each of the following
i) Tightening barbed wires during fencing,
ii) Smoothing concrete floors during plastering.
iii) Administration of liquid medicine to livestock through the mouth.
iv) Processing butter-----
14. 2003: List five tools used when constructing a wooden fence.
15. 2003: a) Diagrams M, N, P and Q represents some farm tools.

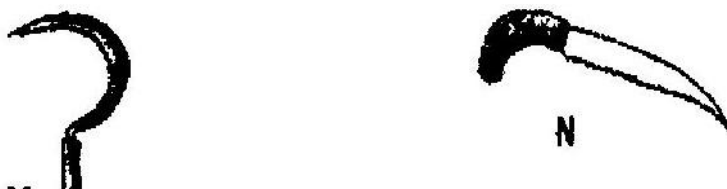

- i) Identify the tools; M,N,P and Q.
 - ii) Give the use of each of the tools named above.
 - iii) State two maintenance practices that should be carried out on tool M.
- (b) The diagram below shows a farm equipment. Study it and answer the questions that follow.

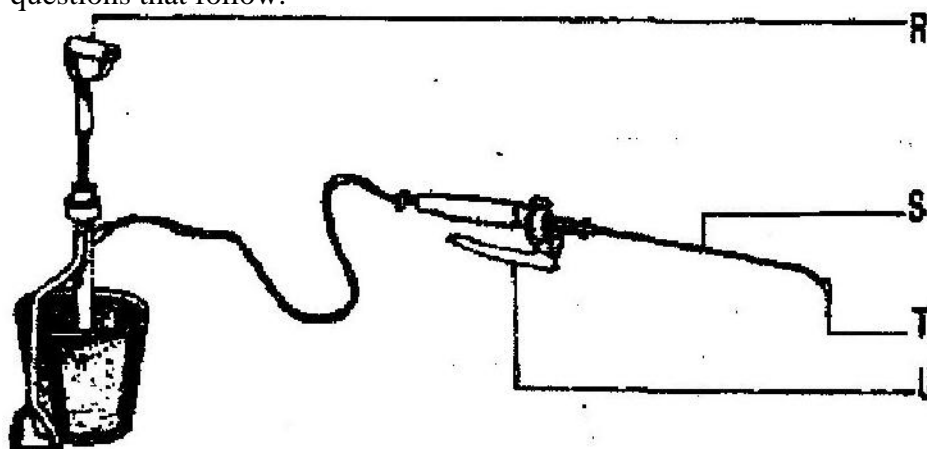

- i) Identify the equipment.
- ii) Name the parts labeled R, S, T and U.

CROP PRODUCTION – LAND PREPARATION

K.C.S.E PAST PAPERS

1. 1994: State 4 reasons for primary cultivation.
2. 1997: State four reasons for primary cultivation.
10. 1999: State four factors which determine the depth of ploughing.
3. 2000: (a) Give two reasons why the use of fire should be discouraged in clearing land during seedbed preparation.
b) Give two reasons for secondary cultivation.
c) State two benefits of minimum tillage in crop production.
4. 2000: List four implements used to carry out secondary cultivation
5. 2001: State two causes of hard pans in a crop field.
6. 2001: Give the maintenance practices of a disc plough.
7. 2002: State reasons why use of fire in clearing land is discouraged.
8. 2003: Outline the main reasons for secondary tillage.
9. 2004: State the main benefits of minimum tillage
10. 2005: a) State one condition under which a farmer would prefer to use an ox-cart instead of tractor – drawn trailer.
b) Give three maintenance practices carried on an ox – plough.
11. 2004: Give four farming practices that may help in achieving minimum tillage.

WATER SUPPLY AND IRRIGATION

K.C.S.E PAST PAPERS

1. 1994: Give the main methods of conveying water from place to place.
2. 1995: State two methods of storing water on a farm.
3. 1995: State two ways of overcoming the problem of water logging in crop production.
4. 1996: State four methods of treating water for domestic use.
5. 1997: (a) Give two ways of conserving water for livestock use.
6. State two means by which water can be conveyed from the place of Storage to where it is needed on the farm.
7. 1998: Name four types of water pumps which can be used on the farm.
8. 1998: List two features of plastic pipes a farmer should consider before buying the pipes.
9. 1998: a) State three factors to be considered before deciding on irrigation in crop production.
b) State three advantages of overhead irrigation compared to surface irrigation.
10. 1998: Give four features of plastic pipes a farmer should consider before buying the pipes.
11. 1998: Name four types of water pumps which can be used on a farm.
12. 1998: Which of these factors would you consider in deciding on irrigation in crop production.
13. 2000: In what way is water useful for agriculture activities?
14. 2000: a) Explain the reasons for treating water on the farm.
b) State the uses of water in the farm.
c) Describe the process involved in water treatment using a chemical treatment system.
15. 2001: Give two factors that influence the quantity of water used in the farm.
16. 2001: State three farming activities which may cause pollution to water sources.
17. 2002: State three advantages of crop irrigation in a farm.
18. 2003: Study the illustration below carefully and answer the questions which follow.

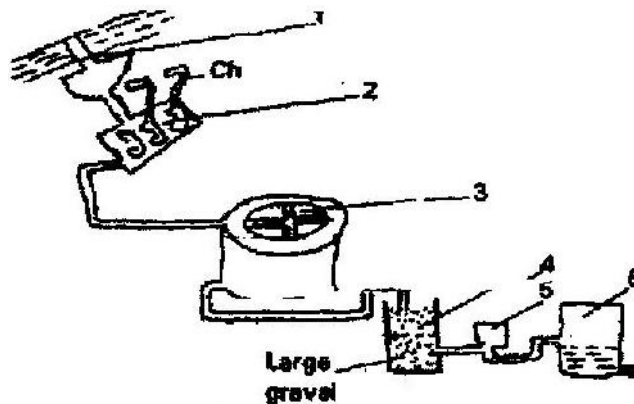

- a) Identify the illustration
- b) Explain part 1 -6
19. 2003: Outline two routine maintenance practices carried out on water storage tanks.

20. 2003: List three types of surface irrigation in crop production.
21. 2003: List four methods used to drain farm land.
22. 2004: a) List three surface water sources found in a farm.
b) Give two reasons for treating water before use in a farm.
23. 2004: Give the reasons why water treatment is important.

SOIL FERTILITY – ORGANIC MANURES

K.C.S.E PAST PAPERS.

1. 1995: How is green manuring carried out on a farm?
1995: (a) Give four reasons why it is advantageous to use farm yard manure instead of straight fertilizer.
(b) State four factors that determine the quality of farm yard manure.
2. 1998: State four ways by which plant nutrients may be lost from the soil.
3. Outline the various benefits of F. Y. M in the farm.
4. 1999: a) Define soil fertility
b) List the major characteristics of a fertile soil.
5. The diagram below is a presentation of a cross section through a compost heap studies it and answer the questions which follow.

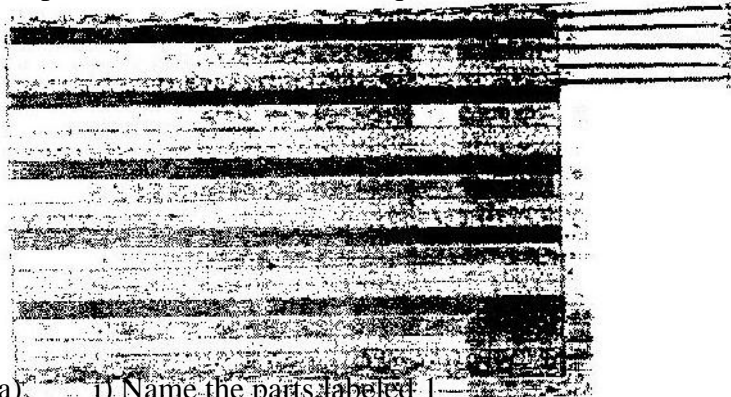

- a) i) Name the parts labeled 1, 2, 3, 4, 5.
Give the importance of 5, 4, 3
- b) Why is it advisable that
 - i) A long sharp pointed stick driven into the heap at an angle.
 - ii) Compost pits be preferably alone in more drier area / weather.
9. 1999: Give four ways by which soil loses its fertility
10. 2000: State four characteristics that make a crop suitable for green manuring.
11. 2002: State three factors that determine the quality of compost manure.
12. 2003: State four characteristics of a fertile soil.
13. 2003: Name three farming practices which may lead to soil erosion.
14. 2005: State three factors which should be considered when sitting a compost heap.
15. 2005: State three advantages of adding organic matter to sandy soil.

LIVESTOCK PRODUCTION – (COMMON BREEDS)

K.C.S.E PAST PAPERS

2. 1996: i) Name the breed of camel that is used for provision of quicker mode of transport and is & better adapted for arid conditions.
ii) Give two reasons why this species of camel is well adapted

- to North par of Kenya.
3. 1998: i) Give two reasons why jersey breeds is better suited for marginal areas than Friesians breed.
 3. 1999: Name the major characteristics of indigenous cattle breeds.
 4. 1999: Give the major features of exotic beef breeds
 1. 2000: Name the exotic cattle with
 - i) Highest butter fat content
 - ii) Lowest butter fat content
 5. 2001: State two characteristics of goats that make them adaptable to arid areas of Kenya.
 6. 2001: Give three ways used to improve & production in indigenous cattle.

AGRICULTURE ECONOMICS – BASIC CONCEPTS AND FARM RECORDS

KCSE PAST PAPERS

1. 1994: List any four types of records a farmer should keep.
2. 2001: State four reasons for keeping health records in livestock production
3. 2005: State the conditions under which the opportunity cost is Zero in a farming enterprise.

SOIL FERTILITY II – INORGANIC FERTILIZERS

KCSE PAST PAPERS

1. 1995/2001: State four characteristics of Nitrogenous fertilizers (2mks)
2. 1996: Calculate the amount of K₂O contained in 400kg of a compound fertilizer 25:10:5. (2mks)
3. 1996: State four functions of Potassium in plant growth. (2mks)
4. Give two symptoms of potassium deficiency in crops (2mks)
5. 1998: State four ways by which plant nutrients may be lost from the soil (2mks)
6. 2001 a) State three functions of nitrogen in crops (2mks)
b) State two symptoms of nitrogen deficiency in a growing maize crop (2mks)
7. 2003: State four effects of excessive application of Nitrogenous fertilizers on crop growth. (2mks)
8. 2004: Give two functions of sulphur in crops (2mks)
9. 2004: Give four deficiency symptoms of phosphorous in crops. (2mks)
10. 2005: List four ways of applying fertilizers in crops (2mks)
11. 2005: a) Differentiate between macro – nutrients and mirco – nutrients (2mks)
b) State four functions of Calcium in plant growth and development (2mks)

CROP PRODUCTION II – PLANTING

KCSE PAST PAPERS.

1. 1995: State four benefits of using vegetative propagation in orange production.(2mks)
2. 1995: (a) Give two advantages of growing cereal crops in rows instead of broadcasting.(2mks)
(b) Give two reasons for planting crops at correct spacing (2mks)
(c) Give two factors that determine the depth at which seeds should

- soil (1mk)
8. 2001: (a) What is crop rotation? (1mk)
 (b) State three advantages of crop rotation. (1mk)
 (c) State three factors considered when designing a crop rotation programme (2mks)

CROP PRODUCTION (V) – VEGETABLES

KCSE PAST PAPERS

1. 1996/2005: (a) Give one cause of blossom end rot in tomatoes
 (b) State two methods of controlling blossom end rot in tomatoes (2mks)
2. 1996/2005: State four factors to consider when grading tomatoes for fresh market.

LIVESTOCK HEALTH – INTRODUCTION

KCSE PAST PAPERS

1. 1996/1997: (a) State three advantages of keeping a herd of dairy cattle health. (3mks)
2. 1997: (a) State two reasons for maintaining livestock in good health. (2mks)
 (b) Name two noticeable diseases in cattle. (2mks)
3. 1999: state two ways by which proper feeding contribute to disease control in livestock. (1mk)
4. 2000: Explain measures used to control livestock diseases. (12 marks)
5. 2002: Give four ways in which diseases can spread from one animal to the other within the farm.

LIVE STOCK HEALTH – PARASITES

KCSE PAST PAPERS

1. 1995: (a) Which livestock disease is transmitted by each of the following ticks? (2mks)
-)
- (i) Blue tick (*Boophilous decoloratus*)
 (ii) Brown ear tick (*Rhipicephalous appendicula tus*)
- (b) How many hosts does the red-legged tick (*Rhipicephalous averts*) require to complete its life cycle? (1mk)
2. 1998: (a) State four signs of infestation by external parasites in livestock? (2mks)
3. (a) State four signs of infestation by external parasites in livestock? (2mks)
 (b) Name the intermediate host for each of the following internal parasites. (2mks)
- Tape worm (*Taenia solium*) (ii) Liver fluke (*Fasciola hepatica*)
4. 200: describe the life cycle of a three- host tick. (8mks)
5. 2003: State four non-chemical methods of controlling ticks in cattle. (2mks)
6. 2004: Give four measures that should be taken to control tapeworms on the farm. (2mks)
-)

LIVE STOCK PRODUCTION (II) – NUTRITION

KCSE PAST PAPERS

1. 1995/2002: What is a production ration as used in animal nutrition? (1mk)
2. 1995: Name two groups into which vitamins are classified. (1 mk)
3. 1996: State 3 factors that influence the amount of water intake by a farm Animal. (1¹/₂ mks)
4. 1996: (a) Differentiate between a roughage and a concentrate feed in animal nutrition. (2mks)
(b) State three ways in which a production ration may be utilized by cattle. (3 mks)
5. 1998: Give four characteristics of a livestock roughage feedstuff.
6. 1998: Outline four functions of proteins in the body of an animal. (2mks)
7. 1999/2002: Outline four factors that determine the nutritional requirements in cattle (2mks)
8. 2000: Give 4 functions of calcium in dairy cow. (2mks)
9. 2001: State four factors that are considered when formulating a livestock ration (2 marks)
10. 2002: (a) Explain the term “production ration” as used in livestock productions. (1mk)
b) State four factor which determine the amount of feed an animal can consume. (4mks)
11. 2004. State three reasons for feeding livestock. (1¹/₂mks)

LIVE STOCK PRODUCTION (III) - SELECTION AND BREEDING

KCSE PAST PAPERS.

1. 1994: (a) How does crossbreeding improve livestock production.
2. 1994: State six signs that are likely to be observed when a cow is on heat
3. 1996: State four disadvantages of natural mating as a method of breeding in dairy cattle management.
4. 1997: Define the term out crossing in animal breeding.
5. The diagram below shows the reproductive system of a cow. Study it carefully and answer the questions that follow.



- a) i) Name the parts labeled A B and C.
ii) State the function of each of the parts labeled a and b
- b) (i) Give two methods of mating in cattle
(ii) How long is the oestrus cycle in cattle?
6. 1998: Explain the term hybrid vigour as used in livestock production.
7. 1999: Describe the factors a farmer should consider when selecting a young female pig (Guilt) for breeding.
8. 2003:
(a) Define the following terms as used in livestock breeding.

- (i) Inbreeding
- (ii) Out crossing
- (b) Outline three disadvantages of artificial insemination in cattle management
- (c) State three desirable characteristics to be considered when selecting a heifer for milk production.

LIVESTOCK PRODUCTION (IV) – REARING PRACTICES

KCSE PAST PAPERS

1. **1994:** Name two kinds of livestock which can be castrated using a rubber ring.
2. **1994:** Give four reasons why bees may swarm from a hive.

3. **1996:** Below is a diagram of a sheep with some parts labeled A, B, and C. Study the diagram and answer the questions that follow.

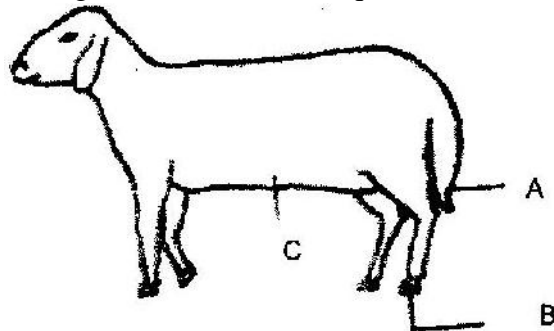

- (i) What operation is usually carried out on the part labeled A during a sheep's early stages of life?
- (ii) Why is it necessary to carry out the operation in (i) above?
- (iii) At what stage of sheep should the operation in (i) above be carried out?
- (iv) Give two methods of carrying out the operation in (i) above,
- (v) Which operation is usually carried out on part labeled B
- (vi) What problem would occur if the operation in (V) above is not carried out?
- (vii) How should the sheep be held when shearing wool around part labeled C?
4. **1998:** Why should smoke be used during harvesting of honey?
5. **1998:** state four reasons for culling breeding sows.
6. **1998:** (a) Define the term colostrums.
(c) Explain three qualities that make colostrums suitable for newly born calves.
(d) Give three methods of feeding colostrums to a newly born calf.
6. **1999:** Give six signs a cow would show just before parturition.
7. **2000:** State four reasons for castrating male piglets.
8. **2000:** Give two qualities of creep feed that makes it suitable for piglets.
9. **2000:** State two reasons why it is necessary to place sugar syrup close to a beehive.
10. **2000:** State four routine management practices that should be carried out on a lactating ewe.

11. **2001:** State six management practices in fish rearing.
12. **2002:** Give five signs, which indicate that a sow is about to farrow.
13. **2002:** State four conditions which would make it necessary to feed bees.
14. **2003:** State four management practices that should be carried out during the mating season in sheep.
15. **2005:** Name four species of fresh water fish reared in Kenya.

FARM STRUCTURES.

1. **1994:** The diagram below represents a calf pen. Study it to answer the questions that follow.

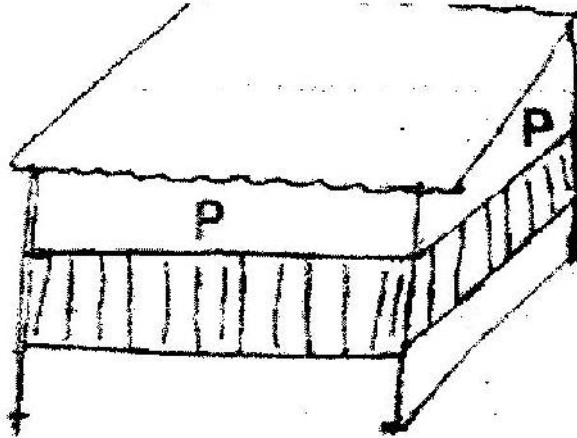

- (i) How high should the floor be above the ground level?
(ii) Why should the floor of the calf pen be raised?
(iii) Why should the parts of the pen marked p be open?
(iv) State three factors that should be considered in sitting a calf pen?
2. **1995:** State two advantages of using wood in the construction of farm buildings
3. **1995:** Describe the construction of a rabbit hutch under the following sub-headings.
4. **1996:** Give two reasons for treating timber to the used in construction of farm buildings.
5. **1996:** State one advantage and one disadvantage of using barbed wire instead of plain wire for fencing paddocks.
6. **1996:** State two functions of ventilation in an animal house.
7. **1996:** a) One of the recommended ratio of mixing ingredients for making Concrete block is 1:3:4, Name ingredients represented by the numbers 1, 3 and 4 in the mixture.
b) If stronger concrete blocks were to be made, name the ingredient that would be increased.
c) State three properties of concrete that make it suitable for constructing farm buildings.
d) In addition to concrete, name three other materials that would be required to construct the floor of milking shed.
8. **1997:** State four features of a good maize granary.
9. **1998:** State two reasons why maintenance of farm structures is important.
10. **1998:** a) State any four factors that would influence the sitting of a calf pen.
b) State four factors to consider when selecting materials for constructing a calf pen.
c) Give four maintenance practices that should be carried out on a permanent calf pen.
11. **1999:** Give two practices, other than use of preservatives, that can be carried out on wooden fencing posts to make them last long.
12. **1999:** State six features of an ideal calf pen.
13. **1999:** Outline any four maintenance practices that should be carried out in a deep litter poultry house.

14. **2001:** Give two advantages of concrete blocks over timber as building materials.
15. **2001:** a) State the uses of fences in farms.
b) What factors would be considered when sitting a farm structures.
16. **2002:** a) State four advantages of a hedge in a farm.
17. **2003:** State four advantages of using a Kenya Top Bar Hive ove log hive.
18. **2003:** Outline two routine maintenance practices carried out on water tanks.
19. **2004:** a) Explain the uses of various hand tools in the construction a Kenya Top Bar Hive
b) Describe the procedure of erecting wooden posts for fencing.
20. **2005:** State three disadvantages of using steel in construction of farm buildings.

SOIL AND WATER CONSERVATION

KCSE PAST PAPERS

1. **1995:** Give one way through which check dams control soil erosion.
2. **1997:** State two ways by which trees help in soil conservation.
3. **1997:** State two reasons for carrying out soil conservation in a farm.
4. **1998:** State two ways by which grass cover help to conserve soil.
5. **2003:** State two ways by which inorganic mulch help to conserve water in the Soil.
6. **2004:** Define the terms;
a) Forestation
b) Re-a forestation
7. **2005:** Outline three factors, which may influence soil erosion.

WEEDS AND WEED CONTROL

KCSE PAST PAPERS

1. **1998:** State four reasons why timely weed control is advisable in crop production.
2. **2000:** Give four ways of controlling weeds in a maize field. (2mks)
3. **2000:** PP2: Diagram & and H show weeds.
i) Identify the weeds. (2mks)
ii) State the economic importance of the weed shown in diagram G (2mks)
iii) Why is it difficult to control weed in diagram G? (1mk)
4. **2001:** State six disadvantages of weeds in crop production (3mks)
5. **2004:** (i) State four factors that contribute to the competitive ability of weeds. (2mks)

6. **2004:** The diagram below represents a weed.



- i) Identify the weed (1/2 mrks)
- ii) Classify the weed according to its life span. (1/2 mark)
- iii) State one harmful effect of the weed to livestock. (1mk)

AGRICULTURE ECONOMICS (II)- LAND TENURE AND REFORMS

KCSE PAST PAPERS

1. **1997:** State four disadvantages of communal land tenure system.
2. **1999:** Give two ways in which land consolidation helps to improve farm management.
3. **2003:** State four objectives of land settlement which have been undertaken in Kenya
4. **2005:** Give two forms of collective land tenure system in

CROP PESTS AND DISEASES

KCSE PAST PAPERS

1. **1994: PP2**
Below is a diagram of a bird labeled A. Which is a crop pest?



- i) Identify the pest
 - ii) State two ways by which the bird causes loss in crops.
 - iii) State four methods, which are used to control the pests.
2. **1995:** The diagram labeled D below shows a Kale crop invested by a pest

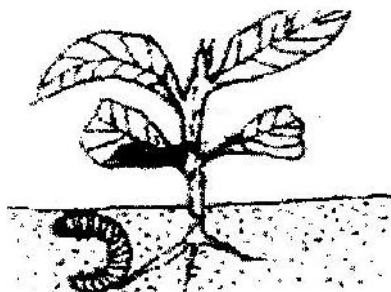

- i) Identify the pest.
- ii) What damage does the pest cause the crop?
- iii) State two methods of controlling the pest
- 3. **1995:** Give two methods of controlling the pest?
- 4. **1995:** State two cultural methods of controlling bollworms in a crop of cotton.
- 5. **1996:** Give two ways of controlling bacteria blight in cotton.
- 6. **1998/1999:** State four factors that affect the effectiveness of a pesticide.
- 7. **1999:** a) State two feeding habits of field insect pests.
b) State two cultural methods of pest control in stored grains.
- 8. **1999:** Explain how various practices carried out in the field help to control crop diseases.
- 9. **2003:** State three cultural ways of controlling nematodes in a field of bananas.
- 10. **2003:** a) Define the term "Economic Injury Level" of a crop.
b) Give two ways by which pesticides kills crop pests.
c) State four disadvantages of chemical pest control in crop production.
- 11. **2004:** Give three harmful effects of pests in crop production
- 12. **2005:** State two cultural methods in controlling bollworms in a tomato crop.
- 13. **2005:** Give two possible causes of swelling on the roots of bean plants.

CROP PRODUCTION (VI) FIELD PRACTICES (II)

KCSE PAST PAPERS.

- 1. **1994:** Name two field pests and two diseases of millet.
- 2. **1996:** Why is it advisable to apply a straight nitrogenous fertilizer to a crop of maize at a height of 30 – 45cm.
- 3. **1996:** Which disease causes a mass of dark spores on the flowering parts of maize?
- 4. **1996:** State any four non – chemical methods of controlling storages pests in a maize granary.
- 5. **1996:** List four insect pests of maize in storage.

- 6. **1996:** PP2 The diagram below labeled G, H, J and K shows different stages of cotton fruit.



- i) Rearrange the label G, H, J, and K to show the correct sequence in which the cotton fruit develops.
 - ii) What would be the effect of attack by cotton boll worms at the stage labeled K?
 - iii) State two conditions that should be observed when harvesting to ensure that cotton picked is of high quality.
 - iv) Name the two products which are obtained after processing cotton.
7. **1997:** State four practices used to control maize streak in the field.
8. **1998:**
- i) State two cultural methods of controlling pests in an established field of sorghum.
 - ii) List any four insect pests that attack maize in the field.
9. **2000:** Give four ways of controlling weeds in a field of maize.
10. **2000:** Give four control measures of maize streak virus.

FORAGE CROPS

KCSE PAST PAPERS.

- 1997 / 1995:** State two advantages of establishing a mixed grass legume pasture instead of planting a pure grass pasture.
2. **1996:** Give two disadvantages of overstocking in cattle production.
3. **1997:** State two roles of additives in silage making.
4. **1997:**
- a) Define the following term, (i) Under sowing (ii) Over sowing
 - b) State three methods of controlling weeds in a pure grass pasture.
 - c) Give three benefits of top dressing in the management of grass pastures.
5. **1998:** State four ways by which a farmer can make efficient use of a pasture crop.
6. **1999 / 2004:** Give four factors that determined the nutrient content of hay.
7. **2000:** State four advantages of under sowing in pasture production
8. **2003:** Describe field production of Napier elephant grass under the following sub-headings.
- i) Seedbed preparation
 - ii) Planting
 - iii) Fertilizer application
 - iv) Weed control
 - v) Utilization
9. **2004:**
- (a) List three pasture legumes grown in medium altitude zones.
 - (b) Give three advantages of rotational grazing.
 - (c) State three ways by which overheating can be prevented in the process of making silage.
10. **2005:** State two advantages of proper stocking pasture management.
11. **2005:** Explain the following terms as used in pasture establishment.
- a) Seed Inoculation
 - b) Over sowing

LIVE STOCK HEALTH (III) – LIVESTOCK DISEASES

KCSE PAST PAPERS.

1. **1994:** List six routes through which pathogens can enter the body of an animal.
2. **1995:** State two methods of controlling rinder pest disease in cattle.

3. **1994/1996:** Give four symptoms of Newcastle disease in poultry.
4. **1996:** State four predisposing factors to the occurrence of mastitis in dairy cattle.
5. **1996:** State any three symptoms of mastitis in dairy cattle.
6. **1997:** Name two notifiable diseases in cattle.
7. **1996/2004:** State two measures that should be taken to prevent an outbreak of Newcastle disease in poultry.
8. **1997: PP2:** The diagram below shows the head of a chicken having symptoms of a poultry disease.
 - i) Identify the disease
 - ii) Give two reasons why the disease is of economic importance to the farmer.
 - iii) State any two methods of controlling the disease.
9. **1999:** State four symptoms of foot rot in sheep.
10. **2009:** Name the causal agents for each of the following disease,
 - i) Coccidiosis
 - ii) Black quarter
11. **2000:**
 - i) State two predisposing factors of foot rot in sheep.
 - ii) Give three symptoms of anaplasmosis disease.
12. **2000:** Explain measures used to control livestock diseases. (12mks)
13. **2001:** Give two signs that would indicate that a cow has died of anthrax.
14. **2001:**
 - a) Name the causal organism of brucellosis in cows (1mks)
 - b) Give two symptoms of brucellosis in cows.
 - c) State four measures that should be taken to control brucellosis in cattle.
15. **2002:** Give three methods of controlling rinderpest in cattle.
16. **2004:** Mention four symptoms of East Coast Fever in cattle.
17. **2005:**
 - a) State the cause of milk fever in dairy cows. (1mks)
 - b) Give four symptoms of milk fever in dairy cows.
 - c) State two methods of controlling milk fever.

LIVESTOCK PRODUCTION – POULTRY

KCSE PAST PAPERS

1. **1995:** Give three methods of controlling cannibalism in a flock of layers in deep litter system.
2. **1995:** List four factors that should be considered when grading eggs for marketing.
3. **1998:**
 - a) Describe the artificial rearing of layer chicks from day old up to the end of brooding.
 - b) Describe the characteristics of a poor layer, which should be considered during culling
4. **1999:** Outline any four maintenance practices, which should be carried out in a deep litter poultry house. (2mks)
5. **2000:** Give four conditions that reduce the quality of eggs for hatching. (2mks)
6. **2001:** Give four measures that can control egg eating by hens in a deep litter system (2mks)
7. **2002:**
 - a) State four observations on the behaviour of chicks which would indicate that the temperature of a brooder is too high. (4mks)
 - b) Give four advantages of deep litter system of poultry keeping. (4mks)

8. **2005:** List six qualities of eggs suitable for incubation (3mks)
9. **2005:** Describe the steps to be taken in maintaining hygiene in a deep litter poultry house. (5mks)

LIVESTOCK PRODUCTION (VI) – CATTLE

KCSE PAST PAPERS.

1. **1995:** (a) The diagram below is a cross section of part of a cows udder

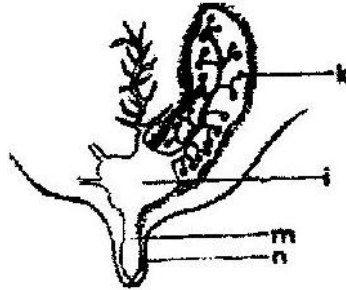

Label on the diagram the parts marked k, l, m and n.
(2mks)

- (b)
 - i) What is milk let down? (1mk)
 - ii) Which hormone stimulates milk let down.(1mk)
 - (c) State three practices which are carried out to control mastitis in lactating cows.
2. **1995:** Describe the management of a dairy heifer calf from birth until it is mature for first service. (20mks)
 3. **1997:**
 - a) Name any two characteristics of good quality whole milk. (1mk)
 - b) State three advantages of artificial calf rearing. (3mks)
 4. **1998:** State four qualities of clean milk. (2mks)
 - a) Define the term colostrums (1mk)
 - b) Explain three qualities that make colostrums suitable for newly born calves. (3mks)
 - c) Give two methods of feeding colostrums to a newly born calf. (1mk)
 5. **1999:** State any six practices that would ensure clean milk production (3mks)
 6. **2000:** State six marketing problems affecting dairy farming in Kenya. (3mks)
 7. **2001:** Describe the management of a dairy calf using artificial rearing method from birth to weaning (20 mks)

FARM POWER AND MACHINERY

KCSE PAST PAPERS

1. **1995:**
 - (a) States four advantages of farm mechanization (2mks)
 - (b) Give the functions of each of the following parts of a mould board plough. (4mks)
 - (i) Mould board
 - (ii) Share
 - (iii) Frog
 - (iv) Landslide.
 - (c) Give two daily maintenance practices that should be carried out on a mould board plough. (2mks)
2. **1995:** The diagram below is a tractor drawn implement hitched at the rear of the



tractor.

- (i) Identify the implement (1mk)
 - (ii) What is the method of power transmission for operating the implement? (1mk)
 - (iii) State three maintenance practices that should be carried out on the implement. (3mks)
3. **1996** a) Compare the use of an ox-drawn mould board plough with that of a tractor-drawn mould board plough. (9mks)
- b) Describe the maintenance practices that should be carried out on an ox-drawn mould board plough (6mks)
- c) What are the advantages and disadvantages of using tractor hire service farming instead of owning and using your own tractors. (5mks)
4. **1997** a) State two reasons of applying oil and grease on a rotary mower. (2mks)
- b) State four maintenance practices required on a rotary mower besides oiling and greasing. (2mks)
- c) State four factors that a farmer should consider before buying a tractor for use as the source of power on the farm. (2mks)
5. **1999** a) Give two uses of ox –drawn harrow (2mks)
- b) Give two maintenance practices of a ox-drawn tine harrow. (2mks)
- c) State two advantages of an ox- drawn harrow over tractor-drawn harrow. (2mks)
6. **2000:** Out line four maintenance practices of a disc harrow. (2mks)
7. **2001** a) State one method of increasing ploughing depth when using a disc plough. (1mk)
- b) State two reasons for maintaining a disc plough, (2mks)
- c) State three advantages of farm mechanization. (3mks)
8. **2003** a) State two functions of a coulter in a mould board plough. (2mks)
- b) Give three maintenance practices carried out on an Ox-drawn trailer. (3mks)
9. **2004** a) State two problems associated with tractor hire service that farmers

- encounter. (1mk)
- b) List four implements used to carry out secondary cultivation. (2mks)
10. **2005** a) State one condition under which a farmer would prefer to use an ox-cart instead of a tractor-drawn trailer.
- b) Give three maintenance practices carried out on an ox-plough., (3mks)

AGRICULTURE ECONOMIC III- PRODUCTION ECONOMICS

1. **1995:** (a) State four ways of improving the labour productivity of farm labour. (2mks)
- (b) What is increasing returns in a production? (1m ark)
- (c) What are three classifications of farm credits according to the repayment periods? (1 ½ mks)
2. **1996:** a) Define the term opportunity cost as used in economics. (1mk)
- b) What is working capital in a farming situation (1mk)
- c) Define the term utility of a commodity as used in agriculture economics. (1 mk)
3. **1997:** (a) State any two sources of capital for farming
- (b) Explain the advantages of budgeting in farm business. (5mks)
4. **1998:** a) Explain the difference between fixed costs and variable costs in farming.
- b) Give four variable costs in the production of coffee in an established field of coffee. (2mks)
- c) Give 3 advantages of planning in a farm business. (3mks)
5. **1999:** Give two uses of gross margin analysis in farm business.

6. **1999:** a) Below is a graphical representation of The law of admonishing returns.

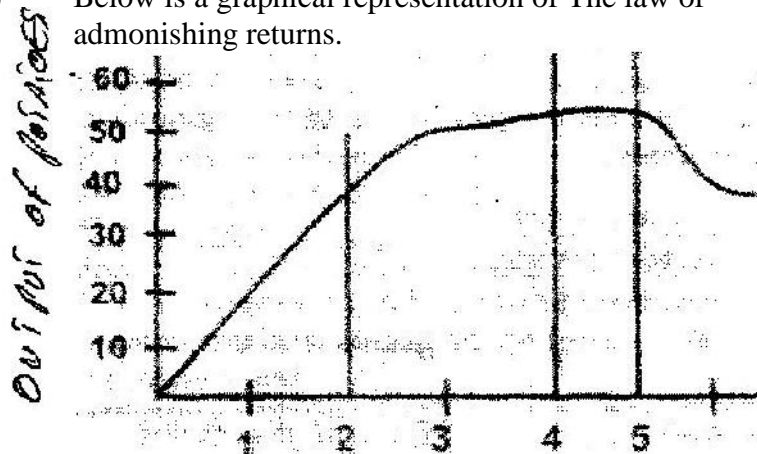

- a) Explain what happens in each of the Zones marked I, II and III in relation to output.(3mks)
- b) Which of the three is a rational zone of production? (1mks)

- c) State any three precautions a potatoes farmer would take to minimize risks in the production of potatoes. (2mks)
7. **2000:** a) State three ways of improving labour productivity in a farm.
 b) Give two changes that would indicate improvement of labour efficiency in farm. (2mks)
 c) State two ways of determining the rate of payment of casual labour in a farm. (3mks)
8. **2001:** a) State four factors that influence the supply of casual labour in a farm.(2mks)
 b) State six ways by which a farmer can risk and uncertainties.
 c) State six reasons why agriculture is important in Kenya economy.(3mks)
9. **2002:** State 2 reasons for choosing the right enterprise combination in farming business. (1mks)
10. **2003:** a) Give four examples of joint products in livestock production.
 b) List four variable inputs in poultry production.
 c) A farmer can combine dairy meal and home made in

Dairy meal (kg)	Home made feed (kg)	Marginal rate of substitution
1	48	O
2	39	V
3	32	7
4	27	W
5	23	4
6	21	X
7	20	1
8	19	y

- i) Given the above information, calculate the marginal rate of substitution and give values of V, W, X and X (4mks)
- ii) Given that the pride of dairy meal is Ksh. 8.00 per kilogram and that of homemade feeds in Ksh. 2.00 per kilogram, calculate the least cost combination. (1mks)
11. **2004:** a) Name three – product relationship in agriculture economics.
 b) Explain the following terms as used in agriculture economics.
 i) Production function
 ii) Equi–marginal returns.
12. **2005:** Name five sources of agriculture credit in Kenya (1 ½ mks)
13. Give two examples in each case of the following costs incurred in the production of milk.
 a) Variable costs (1mk)
 b) Fixed costs (1mks)
14. **2005:** a) Differentiate between partial budget and complete budget. (2mks)
 b) Explain how factors may adjust uncertain rules in farming business (2mks)

The cost of fertilizer is Kshs. 1500 per unit and the price of maize in Ksh. 1200 per bag.

- i) At what unit of fertilizer input should the farmer be advised to stop applying any more fertilizer to the maize.
- ii) Give two reasons for your answer in b (i) above.
- iii) Calculate the marginal return at the point of optimum production.

AGRICULTURAL ECONOMICS

(FARM ACCOUNTS)

1. **1996:** a) List four types of financial books farmers should keep. (2mks)
- 1996:** State two uses of a balance sheet. (2 mks)
2. **1998:** Study the following information which was extracted from Mr. Rambo's farm record on 31 -12 – 95 and answer the question below.

	Kshs.
Loans payable to bank	300,000
Five milking cows	250,000
400 layers	80,000
20 goats	30,000
Debts payable to cooperative	20,000
Buildings and structures	600,000
Bonus payable to workers	19,000
Cattle feed in store	10,000
Animal drugs in store	4,000
Debts receivable	18,000
Breakages to repair	30,000
I cash at hand	20,000
I Cash in bank	30,000
Spray equipment	12,000

Prepare a balance sheet for Rambo's farm using the information above 7 mks

3. **2001:** a) Explain the following terms as used in farm account.
 - i) Cash account
 - ii) Ledger
 - iii) Balance sheet
 - iv) Purchase order.

Name two types of inventories used in farm accounts. (2mks)
4. **2002:** On 5 – 1- 2001 Tamu farm purchased on credit the following items from a K. F. A shop.
 - 20 bags of dairy meal, 70kg each @ sh. 1,100 per bag.
 - 16 bags of bran, 70kg each @ sh. 700 per bag.
 - 18 bags of D.S.P fertilizer, 50kg each @ sh. 1,500 per bag.
 - 45 bags of seed maize, each 2kg @ Ksh. 300 per bag.
 - 8 shearing knives (medium size) @ sh. 300 per knife.
 - i) Prepare the purchase order that Tamu farm made to K.F.A. (6mks)
 - ii) Calculate the value of each item purchased and the total value of the order.(3mks)
5. **2004:** The following accounts information is from Mrs. Mbuta's farm for the year ended 31 – 12 – 2003.

Opening valuation	Ksh. 6,000/=
Paid wages	Ksh. 5000/=
Bought equipment worth	Ksh. 8,000/=
Bought pig feeds worth	Ksh. 4,000/=
Sold mature pigs worth	Ksh. 7,000/=
Bought drugs worth	Ksh. 3,200/=
Sold maize worth	Ksh. 3,000/=

- Closing valuation Ksh. 4,000/=
- i) Using the information above, prepare a profit and loss account for Mrs. Mbuta's farm.
 - ii) From the calculations in (i) above, state whether Mrs. Mbuta made a profit or a loss. (1mk)
6. **2005:**
- a) What is opening valuation as used in farm account? (1mks)
 - b) State the use of each of the following financial documents (3mks)
 - i) Cash receipt
 - ii) Purchase order.
 - Mi) Delivery note.

AGRICULTURAL ECONOMICS

(AGRICULTURAL MARKETING AND ORGANIZATION)

1. **1995:**
 - a) What is the minimum number of people required to form a co-operative society? (1mks)
 - b) State four factors that may influence the supply of a commodity in a market? (4mks)
 - c) State four problems that farmers are likely to face when marketing their produce. (4mks)
 - d) Name two marketing organizations for coffee in Kenya. (1mk)
2. **1996:**
 - a) Differentiate between market and marketing? (2mks)
 - b) What is an imperfect market? (1mk)
 - c) How will the price of mangoes in the short run be affected if the quantity of mangoes supplied in a market is increased
 - d) State any four problems a dairy farmer is likely to face in marketing milk. (2mks)
3. **1997:**
 - a) State the law of demand. (1mk)
 - b) State four factors that determine the demand of a commodity in a free market economy. (4mks)
 - c) What is elasticity of demand for a commodity? (1mk)
 - d) Explain the functions of agricultural marketing boards. (15 mks)
4. **1998:**
 - a) Give four benefits a farmer would derive from being a member of a dairy co-operative society. (2mks)
5. **1999:**
 - a) Explain the problems farmers face in marketing of agricultural produce. (9mks)
 - b) Describe the various agencies and institutions involved in marketing of a agricultural produce. (5mks)
6. **2000:**
 - a) State six factors that influence demand for a commodity in a market. (3mks)
7. **2003:**
 - a) Given that at a price of Ksh.100 per bag, 20 bags of maize are demanded, but when the price changes to Ksh.800 per bag, 22 bags of are demanded. Calculate the elasticity of demand. Show your working. (3mks)
8. **2003:**
 - a) Describe the functions of agricultural marketing (10mks)
 - b) Explain the role of agricultural co-operatives in Kenya. (10mks)
9. **2004:**
 - a) State six problems experienced by farmers in marketing agricultural produce. (3mks)

K.C.S.E AGRICULTURE PAPER 1 2006
SECTION A (30 marks)

Answer all the questions in this section in the spaces provided

1. Differentiate between Olericulture and pomoculture as used in crop production (1 mk)
2. State three ways by which biological agents can enhance the process of soil formation (1 ½ mk)
3. State four advantages of drip irrigation (2 mks)
4. State four advantages of adding organic manure to a sandy soil (2 mks)
5. State two factors that would determine the amount of fertilizer to be top dressed to a crop in the field (1 mk)
6. State four advantages of applying lime as a measure of improving soil condition (2 mks)
7. Give four reasons for using certified seeds for planting (2 mks)
8. Give four reasons for planting crops at the correct spacing (2 mks)
9. State three effects of soil erosion (2 mks)
10. Name four methods used to control weeds in pastures (2 mks)
11. State two benefits of conserving forage crops (2 mks)
12. Mention four practices that should be carried out to maintain grass pasture (1 ½ mks)
13. Define the following terms as used in agriculture economics
 - (a) Gross domestic product (GDP) (1 ½ mks)
 - (b) Per capita income (½ mks)
14. What is profit maximization in agriculture economics? (½ marks)
15. State four benefits of budgeting to a farm manager (2 mks)
16. Give two reasons why farmers keep farm accounts
17. State activities carried out by young farmers club in Kenya (2 mks)
18. State four ways by which afforestation helps in land reclamation (2 mks)
19. State three advantages of multiple stem pruning over single stem pruning in coffee (1 ½ mks)

SECTION B (20 mks)

Answer ALL the questions in this section in the spaces provided

20. Two maize pests are shown in the diagram below. Study them and answer the questions that follow,

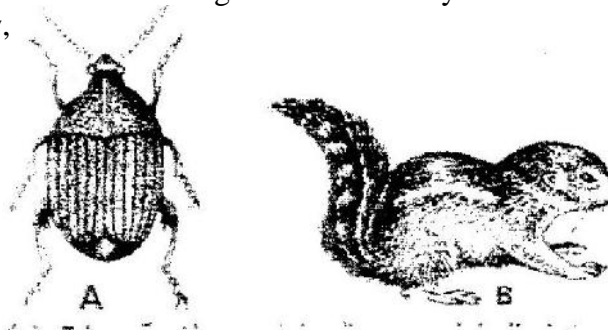

- (a) Identify the pests in the diagram labeled A and B (1 mk)
- (b) at what stage of maize production does each damage the crop?
- (c) Give one way of controlling each of the pests in the field
- 21 (a) state the law of diminishing returns in a production process
- (b) Use the information on the table below to answer the questions that follow

Fertilizer input (units)	Maize yield (bags)	Marginal productions (bags)
0	50	12

1	62	12
2	66	4
3	68	2
4	69	1
5	69	0

The cost of fertilizer is Kshs 1500 per unit and the price of maize is Kshs 1200 per bag.

- (i) At what unit of fertilizer input should the farmer be advised to stop applying any more fertilizer to the maize? (1mk)
- (ii) Give a reason for your answer in (b) above
- (iii) Calculate the marginal return at the point of optimum production (1mk)

22. (a) Describe the procedure which should be followed in spraying a crop in tomatoes using a fungicide in powder form, water and a knapsack sprayer. (3 mks)

- (b) Name one fungal disease of tomatoes that can be controlled using the above procedure. (1mks)
- (c) State four safety measures that should be taken while spraying the crop with the fungicide. (2mks)

23. The diagram below shows a weed



- a) Identify the weed (1mk)
- b) State two reasons for controlling the weed. (2mks)
- c) Name two herbicides that can be used to control the weed in a field of maize (1mk)
- d) At what stage of growth of maize should the weed be controlled using a post emergence herbicide?

SECTION C (40 MARKS)

Answer any TWO questions in this section in the spaces provided at the end of the section.

24. Describe the establishment of kales under the following sub – headings:
 - a) Nursery preparation

- b) Establishment in the nursery
 - c) Management of seedlings in the nursery.
 - d) Transplanting of seedlings.
- 25.
- a) Outline the factors necessary for proper functioning of farmers' co-operative societies in Kenya. (5mks)
 - b) Explain how farmers overcome risks and uncertainties in a farming business.
 - c) Describe the steps farmers should follow when planning a farm business
- 26.
- a) List various methods of harvesting water in a farm
 - b) Outline farming activities which may encourage soil erosion.
 - c) Explain how various farming practices would help to conserve soil in a farm.

K.C.S.E. 2006 PAPER 2
SECTION A (30 MARKS)

Answer ALL the questions in this section in the spaces provided.

1. Name a breed of sheep with a Lambing percentage of above 125 and whose fleece may be inferior due to black fibres.
(1mk)
2. List two appropriate hand tools needed to finish off the handle of a fork-jembe.
(1mk)
3. What is “cropping” in fish farming? (1mk)
4. State four functions of lubrication system in a tractor. (2mks)
5. Give four maintenance practices carried out on the water cooling system of a tractor. (2mks)
6. State reasons why a farmer would choose to use a disc plough rather than a mould board plough.
(2mks)
7. State four construction features necessary in a fish pond. (2mks)
8. Give four ways in which disease causing organisms can gain access into a newly born calf (2mks)
9. State four ways of controlling tsetse flies. (2mks)
10. Give two predisposing factors of foot-rot in sheep. (1mk)
11. State four factors which should be considered when selecting dairy goats for breeding. (2mks)
12. Give four reasons why camels are suited to living in arid areas. (2mks)
13. Name two functions of the crop in the digestive system of chicken. (1mk)
14. State four methods of dehorning (2mks)
15. Mention six causes of stress to a flock of layers. (3mks)
16. State four functions of the worker bees in a bee colony. (2mks)
17. State four features of a good pig house. (2mks)

SECTION B (20 MARKS)

Answer ALL the questions in this section in the spaces provided.

18. (a) A diagram of a planter is shown below. Study it and answer the questions that follow.

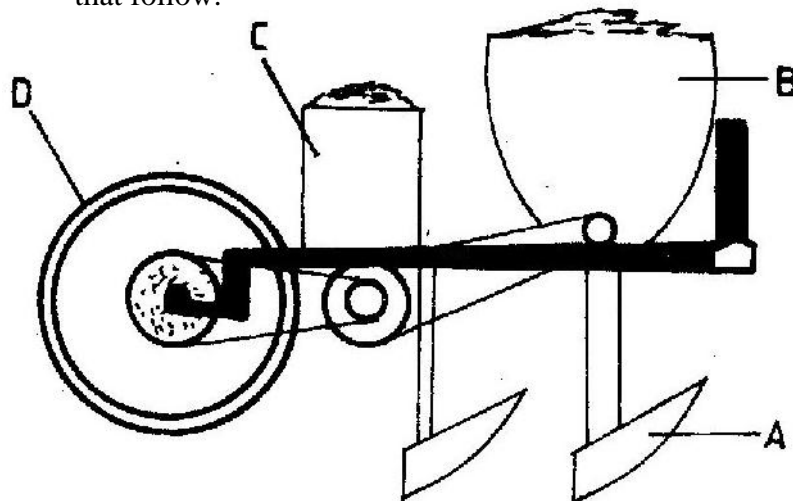

- (i) Identify the parts labelled A, B, C, and D, (2mks)

- A _____
- B _____
- C _____
- D _____

(ii) State two maintenance practices carried out on the planter. (2mks)

b) Study the diagrams of workshop tools shown below



(i) Identify the tools labeled E and F (1mk)

- E _____
- F _____

(ii) What functional advantage does tool E have over tool F? (1mk)

19. The diagram below represents a calf pen. Study the diagram and answer the questions that follow.

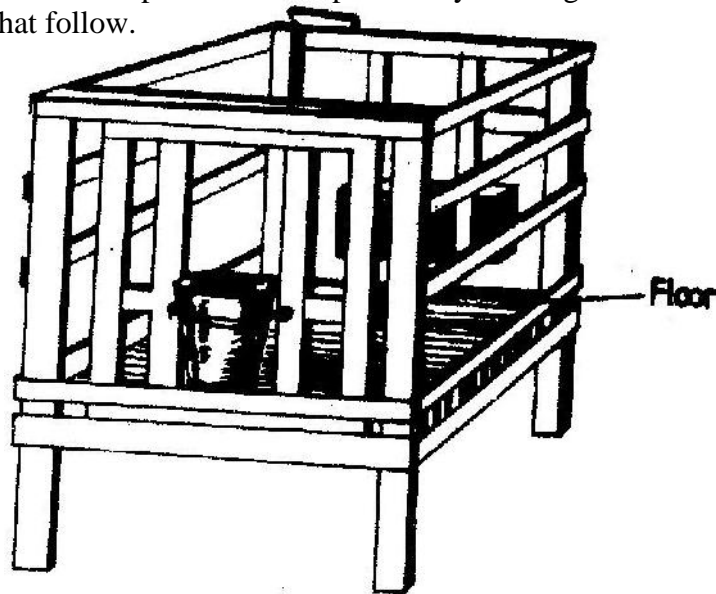

(a) (i) Identify the type of floor. (½ mk)

(ii) How high should the floor be raised above the ground level? (1mk)

(b) (i) Give one reason for having the floor of the calf pen raised. (1mk)

(ii) State three factors that should be considered in sitting the calf pen. (3mks)

20. (a) Define the term digestible Crude Protein (DCP) (½ mk)

- (b) A farmer wanted to prepare a 200kg of calf rearing ration containing 20% DCP. Using the Pears Square Method, calculate the amount of Maize containing 10% DCP and Sunflower containing 35% DCP the farmer would need to prepare the ration. (Show your work)
(4mks)

21. A diagram of a cow is shown below. Study it and answer the questions that follow.

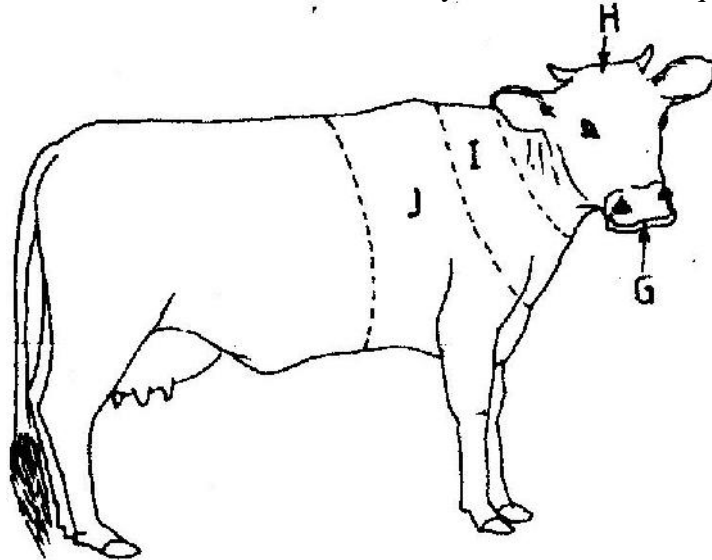

- (a) Name the parts labeled G, H, I and J.

G _____

H _____

I _____

J _____

- (b) Name four parts of the animal preferred by a two host tick.
(2mks)

SECTION C (40 MARKS)

Answer any TWO questions in this section in the spaces provided at the end of the section.

22. a) Outline the procedure followed when hand spraying cattle to ensure effective use of acaricides to control ticks. (10mks)
- b) Discuss Foot and Mouth disease under the following headings:
- (i) Casual organisms. (1mk)
 - (ii) Livestock species attacked. (2mks)
 - (iii) Symptoms of attack. (4mks)
 - (iv) Control measures. (3mks)
23. a) Describe the management practices that a farmer should carry out to improve milk production in a low yielding herd of dairy cattle.(15mks)
- b) Describe the management practices that would ensure maximum yield of fish in a fish pond. (5mks)
24. a) What are the advantages of farm mechanization? (6mks)
- b) Explain the differences between a two stroke and a four stroke cycle engine. (6mks)
- c) Outline the daily maintenance practices that should be carried out on a farm tractor (8mks)

K.C.S.E 2007 AGRICULTURE PAPER 1
SECTION A [30 MARKS]

Answer ALL the questions in this section in the spaces provided.

1. Give **four** conditions of the land which may make it necessary to carry out reclamation practices. [2marks]
2. List **three** physical weathering agents in the soil formation process [1½]
3. State **two** mechanical methods of separating soil particles according to size during soil analysis [1marks]
4. Give **two** benefits of possessing a land Title Deed to a farmer. [1 mark]
5. Give four advantages of crop rotation [2 marks]
6. State four factors that should be considered when classifying crop pest
7. State **three** functions of boron in crop development. [1½]
8. Outline **four** observable indicators of economic development of a nation [2marks]
9. Give three factors that may influence the price of an agricultural commodity.[1½]
10. Name three examples of leguminous fodder crops. [1½]
11. Give two factors that may determine the size of a pit for silage making [1mark]
12. Give three reasons for controlling weeds in pastures. 1½
13. State six characteristics of a productive soil. (3 mks)
14. State any five qualities that should be considered when selecting seeds for planting (2 ½ mk)
15. (a) State four practices which encourage soil erosion (2 mks)
(b) Name two forms of gully erosion (1 mk)
16. (a) State four advantages of land consolidation (2 mks)
(b) Give two advantages of leasehold tenure system in farming (1 mk)

SECTION B (20 MARKS)

Answer all the questions in this section in the spaces provided

17. The table below shows the demand and supply of potatoes at UKULIMA market.

Price (Kshs)	Quantity demanded (in bags)	Quantity supplied (in bags)
1200	50	250
1000	90	200
800	150	150
600	225	70
400	335	0

- (a) Using suitable scales, draw and label a graph showing the relationship between the demand and supply of the potatoes at UKULIMA market. (5 mks)
- (b) What is the equilibrium price of the potatoes? (1 mk)
- (c) From the graph determine:
 - (i) The number of bags of potatoes that would be bought if the price per bag is Kshs 900/= (1 mk)
 - (ii) The price of a bag of potatoes if 180 bags are supplied (1 mk)

18. The diagrams labeled A₁, A₂, A₃, and B below illustrate materials and methods of vegetative propagation. Study them and answer the questions that follow.

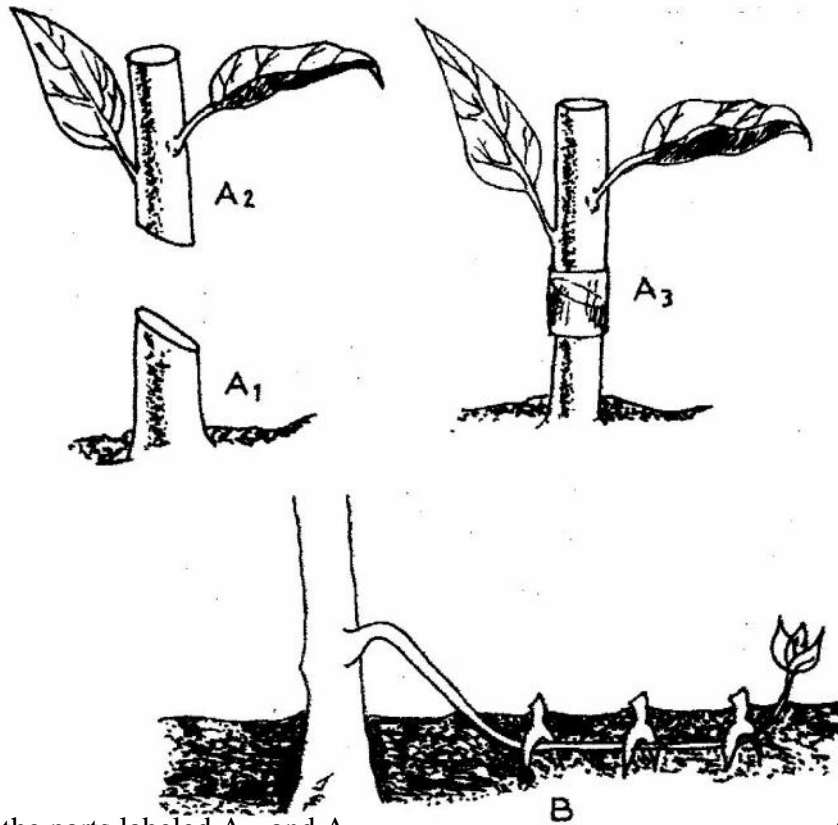

- (a) Name the parts labeled A₁, and A₂ (2 mks)

A₁

A₂

- (b) Name the methods of propagation illustrated in diagrams A₃ and B (2 mks)

A₃

B

19. Study the crop illustrated in the diagram below and answer the questions that follow

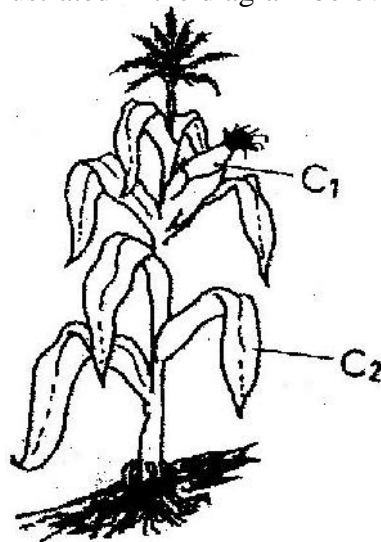

- (a) Name one insect pest which attacks the part labeled C₁ and one disease which attacks the part labeled C₂ (2 mks)

C₁

C₂

20. A member of young farmers club was advised to apply a complete fertilizer 30:20:10 in a tomato plot measuring 10m long by 5m wide at the rate of 300kg per hectare
- (a) State the percentage of P_2O_5 in the complete fertilizer (1 mk)
 - (b) Calculate the amount of fertilizer the member would require for the plot (2 mks) (Show your working)

21. The diagrams labeled D and E below are illustrations of coffee established using two different formative pruning systems. Study them and answer the questions that follow.

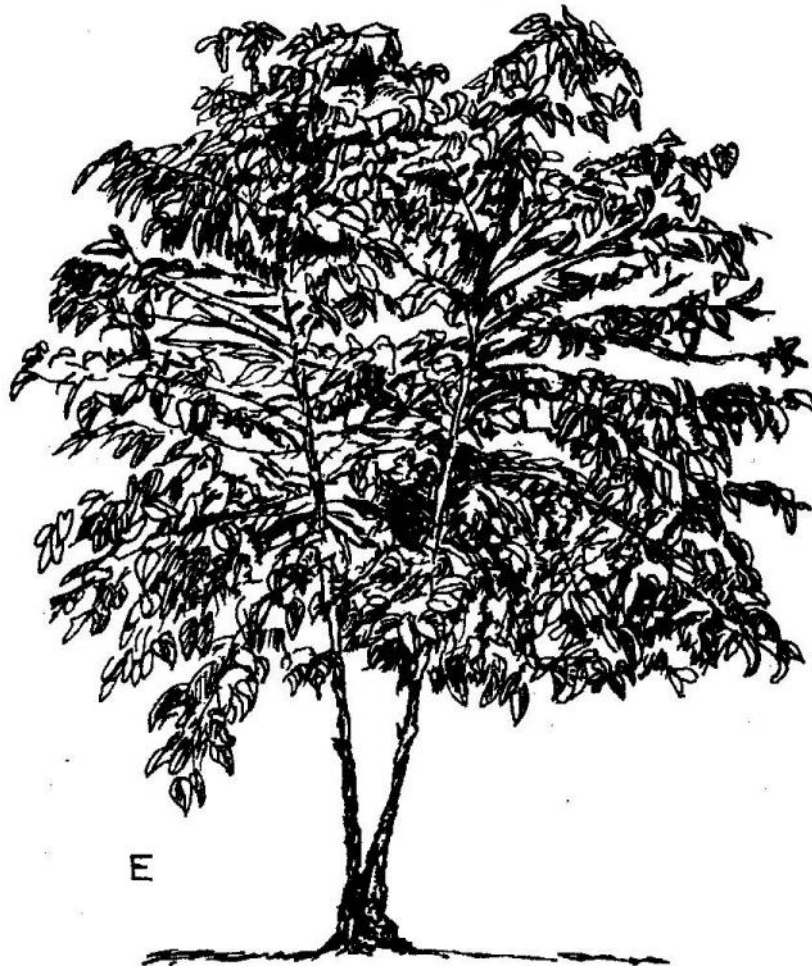

- (a) Name the system of pruning illustrated in diagram D above (1mk)
(b) Outline how the pruning system illustrated in diagram E is carried out (2 mks)

SECTION C (40 MARKS)

Answer any two questions in this section in the spaces provided after questions 24

22. (a) Describe the field production of irrigated rice under the following sub-headings

- (i) Land preparation (7 mks)
- (ii) Water control (6 mks)
- (b) Describe the management of trees grown under various agro- forestry systems (7 mks)
- 23. (a) Describe the problems of marketing of agricultural produce (10 mks)
- (b) Discuss the importance of budgeting in agricultural production (10 mks)
- 24. (a) Discuss the importance of irrigation in farming (12 mks)
- (b) Explain the factors that influence the type of irrigation to be used in a farm (8 mks)

K.C.S.E 2007 AGRICULTURE PAPER 2

SECTION A (30 marks)

Answer ALL the questions in this section in the spaces provided.

1. Give two reasons for using litter in a poultry house. (1mk)
2. Name two diseases of poultry that are controlled by vaccination. (1mk)
3. State two factors that could lead to failure to conceive in sows after service. (1mk)
4. Give two causes of scouring in calves. (1mk)
5. State three factors that would determine the amount of concentrate fed to dairy cattle. (1 ½ marks)
6. Give three ways of stimulating milk let-down in a dairy cow. (1 ½ marks)
7. State two reasons for dehorning cattle. (1mk)
8. List two equipment used in handling cattle during an agricultural exhibition. (1mk)
9. State three signs of anthrax infection disease observed in the carcass of cattle. (1 ½ mks)
10. Give three effects of external parasites that are harmful to livestock. (1 ½ mks)
11. State four factors to consider when siting a fish pond. (2mks)
12. State three adjustments that should be carried out on a tractor – mounted mouldboard plough in preparation for ploughing. (1 ½ mks)
13. a) Name four breeds of dairy goats. (2mks)
b) Mention two distinguishing characteristics of the Bactrian camel breed. (1mk)
14. State five methods of maintaining good health in livestock. (2 ½ mks)
15. List four sources of farm power which are environmental friendly. (2mks)
16. State three maintenance practices that should be carried out on a feed trough. (1 ½ mks)
17. Name four systems of a tractor engine. (2mks)
18. List three types of calf pens. (1 ½ mks)
19. State four conditions that would encourage hens to eat eggs in poultry production (2mks)

SECTION B (20 MKS)

Answer ALL the questions in this section in the spaces provided.

20. The diagrams labeled A and B below show the teeth arrangements in hand workshop tools.

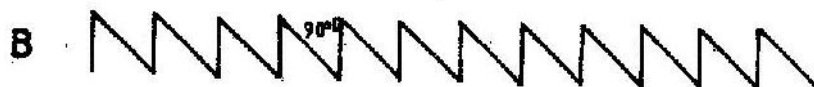

- a) Identify the tools represented with by the teeth arrangements A and B. (1mk)
A
- B
- b) State one functional difference between tools represented by the teeth arrangements A and B.
A
- B

c) Give two maintenance practices for the tools represented by the teeth arrangement shown above. (2mks)

21. a) The diagram below illustrates a method of identification in livestock production. Study the diagram and answer the Questions that follow.

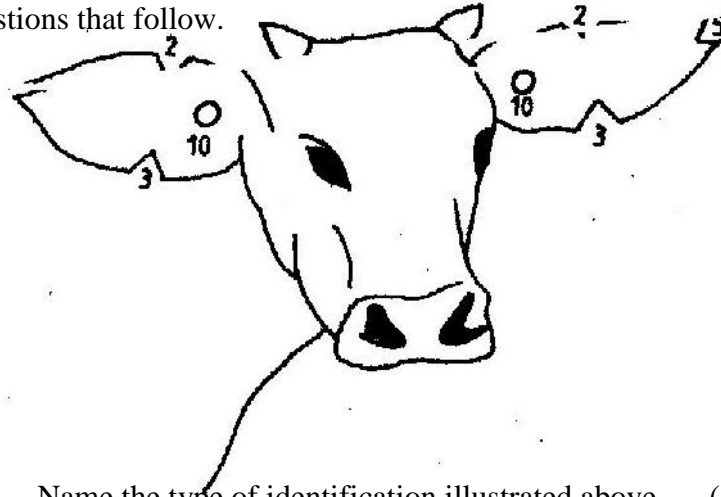

i) Name the type of identification illustrated above. (1mks)

ii) Give the identification number of the animal illustrated in the diagram above. (1mk)

iii) Using diagrams illustrate how you can identify animals Nos 24 and 36 using the above method. (2mks)

Animal No. 24

Animal No. 36

(b) If a sow was successfully served on 27th September, 2006, state the date she is likely to have farrowed. (1mks)

22. The diagram below shows a type of a farm gate. Study the diagram and answer the questions that follow.

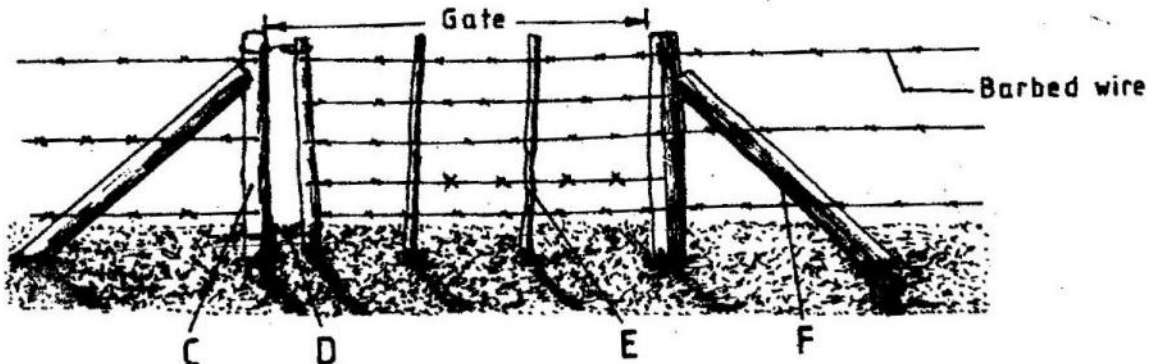

a) Identify the type of gate shown (1/2 mk)

b) Name the parts labeled C, D and E. (1 1/2 mks)

C

D

E

c) i) State one function of the part labeled F. (1mk)

F

ii) State two functions of the gate illustrated above. (2mks)

23. The diagram below shows a farm implement. Study it and answer the questions that follow.

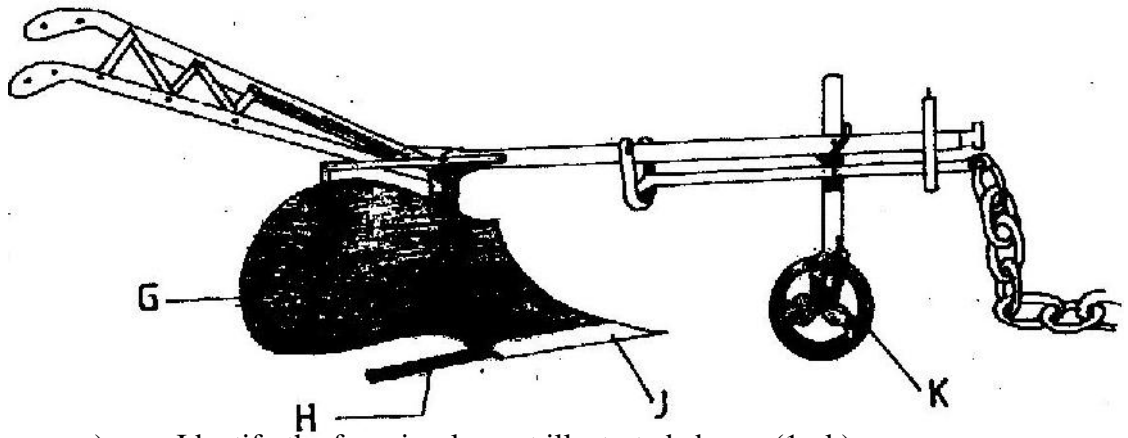

- a) Identify the farm implement illustrated above. (1mk)
- b) Name the parts labeled G, H, J and K.
- G
- H
- J
- K
- c) State four functions of the farm implement illustrated above. (2mks)

SECTION C (40 marks)

Answer any TWO questions in this section in the spaces provided after question 26.

24. a) Describe the advantages of the battery system of rearing layers. (10mks)
- b) Outline the factors to consider when selection livestock for breeding.
25. a) Name the strokes in a four stroke engine and describe how each operates.(12mks)
- b) Describe the functions of the gear box in a tractor. (8mks)
26. a) Name and describe the features of an ideal calf pen. (9mks)
- b) Discuss pneumonia in calves under the following sub – headings:
- i) Predisposing factors (3mks)
- ii) Symptoms (5mks)
- iii) Control measures (3mks)

K.C.S.E YEAR 2008
PAPER 1

SECTION A (30 marks)

Answer ALL the questions in this section in the spaces provided.

1. Give two factors which characterize small scale farming. (1 mark)
2. State two effects of HIV/AIDS on agricultural production. (1 mark)
3. Give two reasons why farmers are encouraged to practice organic farming. (1 mark)
4. Distinguish between soil structure and soil texture (1mark)
5. State two effects of siltation in dams (1mark)
6. List two examples of working capital in crop production (1 mark)
7. (a) Define the term **land reform**. ($\frac{1}{2}$ mark)
(b) Give three methods of land reforms practiced in Kenya. ($1\frac{1}{2}$ marks)
8. State **three** ways by which land as a factor of production could be made more productive. ($1\frac{1}{2}$ marks)
9. State **three** functions of the Coffee Board of Kenya. ($1\frac{1}{2}$ marks)
10. Differentiate between the following terms as used in agricultural economics:
 - (a) Fixed input and variable input, (1 mark)
 - (b) Journal and Ledger book (1 mark)
11. Give **two** methods used for seed treatment of tree species before planting in agroforestry. (1 mark)
12. Give two benefits of border planting form of agro forestry to a farmer. (1 mark)
13. State **three** factors which may affect the quality of hay. ($1\frac{1}{2}$ marks)
14. Give four factors to consider when choosing a nursery site (2 marks)
15. State **three** methods of controlling insect pests in a crop nursery. ($\frac{1}{2}$ marks)
16. Name **one** vegetative material used to propagate each of the following crops:
(2 marks)
 - (a) Bananas.....
 - (b) Pineapples.....
 - (c) Irish potatoes.....
 - (d) Pyrethrum
17. Give **four** disadvantages of broadcasting as a method of planting. (2 marks)
18. State **four** factors that would determine the number of operations to be carried out on a seedbed before planting. (2 marks)
19. State **two** ways by which soil pH may affect crop production-. (1 mark)
20. Give two conditions under which blossom end rot disease may occur in tomatoes.
(1 mark)
21. State four factors that contribute to the competitive ability of weeds. (2 marks)

SECTION B (20 marks)

Answer ALL the questions in this section in the spaces provided.

The diagram below illustrates a feature observed after digging the soil several metres deep. Study the diagram carefully and answer the questions that follow.

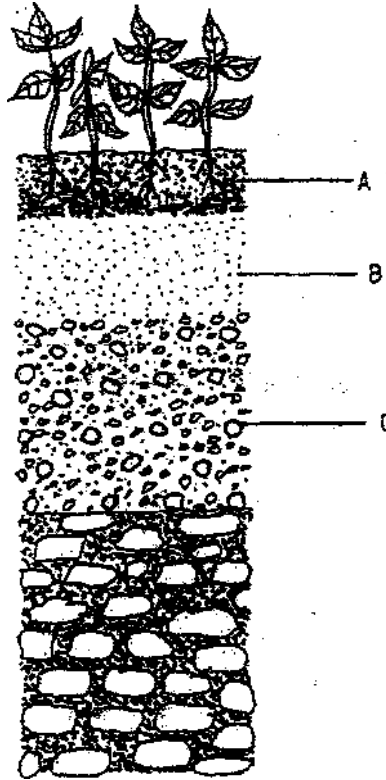

- (a) Identify the feature that the diagram above represents in the study of soil. (1 mark)
- (b) Name the parts of the diagram labelled A, B and C (1½ marks)
- (c) State **two** ways in which the knowledge of the above feature would be of benefit to a farmer, (2 marks)

23 The diagram below illustrates a cereal crop plant and its produce. Study the diagram carefully and answer the questions that follow.

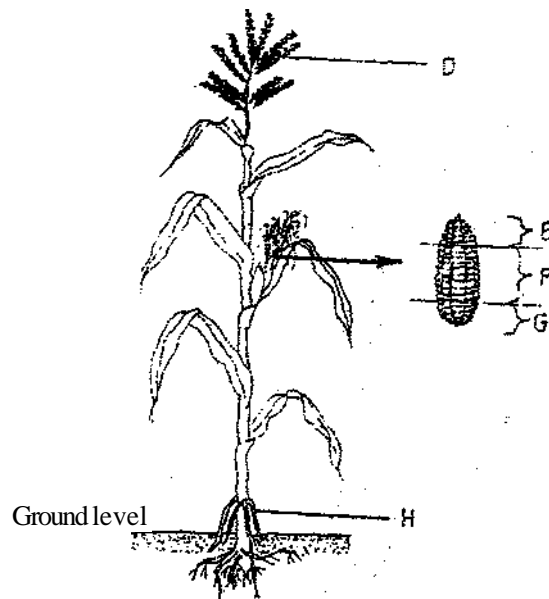

- (a) Name one disease that attacks the part of the plant labelled **D** in the diagram. (1 mark)
- (b) From which section of the produce labelled **E**, **F** and **G** should seeds for planting be obtained? ($\frac{1}{2}$ mark)
- (c) Give **one** reason for the answer given in (b) above. (1 mark)
- (d) State two functions of the part labelled **H** in the diagram
- (e) A farmer has a piece of land measuring 90 m by 60 m to plant seeds selected in (b) above at the rate of one seed per hole and a spacing of 90 cm by 30 cm. Calculate the plant population in the whole field if all the seeds germinated, (show your working). ($1\frac{1}{2}$ marks)

- 24 The diagram below illustrates a parasitic weed. Study the diagram carefully and answer the questions that follow.

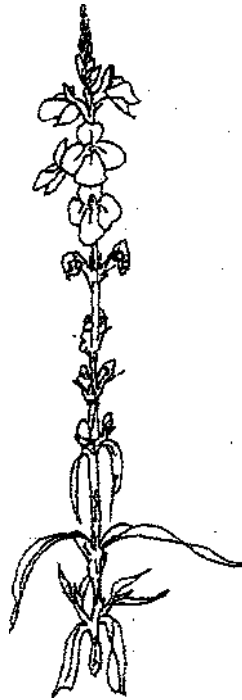

- (a) Identify the weed illustrated above. (1 mark)
- (b) Name two crops the weed illustrated above commonly attacks (1mark)
- (c) State one reason why the weed is referred to as a parasitic weed. (1mark)

- (d) State two methods for controlling the weed illustrated above. (1mark)

25. The following is a farm record Mrs Sanda had kept as at 30* June 2006. Study it carefully and answer the questions that follow.

	Ksh
Cash in hand	20000
Cash at bank	66000
Buildings	50 000
Disc ploughs	16 000
Debtors	16000
Working tools	12000
Bank overdraft	24 000
Creditors	20 000
<i>loan</i>	50000
Cattle	40000
Land	80000

- (a) Prepare the balance sheet from the above information for Mrs Sanda's farm. (6 marks)
- (b) State two benefits of the balance sheet to Mrs Sanda. (1 mark)

SECTION C (40 marks)

Answer any TWO questions in this section in (he spaces provided in this booklet.

2. (a) State and explain five roles of agriculture in economic development of Kenya. (10marks)
- (b) Describe measures which should be taken to minimize water pollution on a farm. (10marks)
27. State and explain:
- (a) Five ad vantages of crop rotation. (10marks)
- (b) Five factors which may influence the spacing of crops. (10marks)

28. (a) Explain why settlement schemes were established in Kenya soon after independence. (30 marks)
- (b) State and explain the various land tenure systems practiced in Kenya. (10 marks)

K.C.S.E AGRICULTURE PAPER 1 2009

SECTION A (30 MARKS)

Answer ALL the questions in this section in the spaces provided

1. List three methods of treating water for use on the farm (1 ½ mks)

2. Give two example for each of the following categories of water pipes
 - (a) Metal pipes (1 mk)

 - (b) Hose pipes (1 mk)

3. State four disadvantages of communal land tenure system (2 mks)

4. List four sites on which agro forestry trees can be established on a farm (2 mks)

5. State four financial documents that should be kept on a farm (2 mks)

6. Give two ways in which check dams control soil erosion (1 mk)

7. List two methods of building that are used in propagation of plants (1 mk)
8. Give two reasons for locating a nursery bed at a well sheltered place (1 mk)
9. State four ways in which burning of vegetation may lead to lose of soil fertility
(2 mks)
10. Give two forms in which nitrogen is absorbed from the soil by plants (1 mk)
11. Why is it necessary to allow freshly cut sorghum (Columbus grass) to wilt before feeding it to livestock?
(1 mk)
12. Give two roles of soil micro- organisms that are beneficial to crops (1 mk)
13. distinguish between the terms hybrid and composite as used in maize breeding
(1 mk)
14. Give three reasons for growing crops under optimum temperature conditions
(1 ½ mks)

15. State two harmful effects of strong wind on crop production (1 mk)

16. Give two ways in which cover crops help to conserve water in the soil

(1 mk)

17. Give a reason for carrying out each of the following management practices on a tree nursery

(a) Pricking out

(1 mk)

(b) Root trimming

(1 mk)

18. Outline two ways of controlling damping of disease on vegetable seedling in a nursery

(1 mk)

19. State four effects of pests with both piercing and sucking mouth parts on crops

(2 mks)

20. Name four natural factors that may influence soil erosion (2 mks)

21. Give two conditions in agricultural production under which opportunity cost is zero

(1 mk)

SECTION B (20 MARKS)

Answer ALL the questions in this section in the spaces provided

22. The diagram below illustrates a maize cob attacked by a disease. Study it carefully and answer the questions that follow.

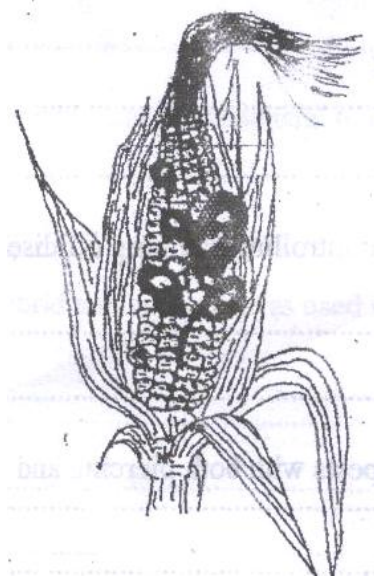

- (a) Identify the disease (1 mk)
- (b) Apart from maize, give two other crops that may be attacked by the disease (1 mk)
- (c) State two methods of controlling the diseases (2 mks)

23. The diagram below illustrates an experiment on soil. Study it carefully and answer the questions that follow

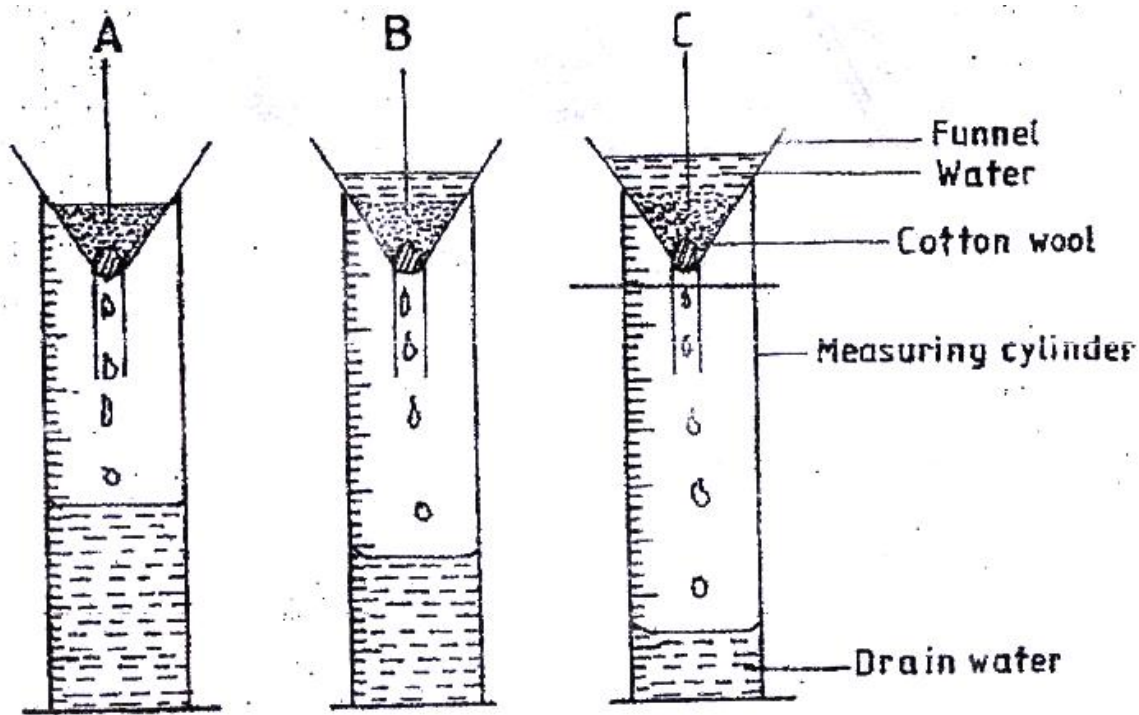

(a) State the aim of the experiment

(1 mk)

(b) If the volume of

water illustrated in the measuring cylinders was observed after one hour, identify the soil samples labeled A and B.

A (½ mk)

B (½ mk)

(c) State two ways in which the soil structure of the soil sample labeled C above can be improved.

(2 mks)

24. The diagram below illustrates a final seedbed after tertiary operation done during land preparation.

Study it carefully and answer the questions that follow.

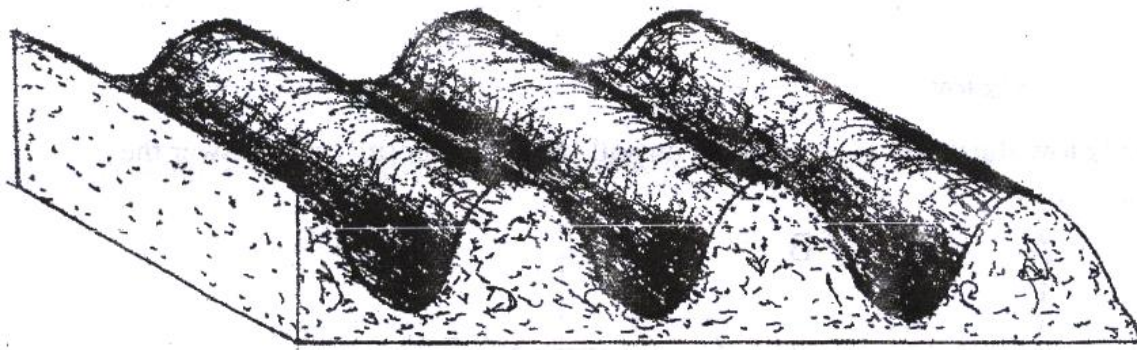

(a) Name
the tertiary
operation
carried out
on the

seedbed (½ mk)

(b) Describe how the tertiary operation named in (a) above is carried out

(1 ½ mks)

(c) Give two advantages of planting crops on the final seed bed illustrated above

(2 mks)

25. What is the function of each of the following ingredients in the preparation of compost manure?

(a) Wood ash (1 mk)

(b) Top Soil (1 mk)

26. Name the deficient nutrient element in plants showing the following symptoms

(a) Stunted growth, die back of plant tips, leaves roll up and chlorosis along margins of younger leaves (½ mk)

(b) Yellowing of leaves appears first lower leaves turn brown and fall prematurely, stunted growth (½ mk)

(c) Leaf curling, yellowing of leaves, tips and edges of leaves are scorched and have small mottles (½ mk)

(d) Purpling of leaves, stunted growth, slender stalks and lateral buds remain dormant (½ mk)

27. (a) Why is the use of the following items essential during the harvesting of tea?

(i) Plucking stick (1 mk)

(ii) Woven basket (1 mk)

(b) Describe ten safety precautions that should be taken when using herbicides to control weeds (10 mks)

28. (a) Explain five advantages of mulching in crop production (5 mks)

(b) Outline five activities that may be undertaken in organic farming (5 mks)

(c) Discuss ten benefits a farmer is likely to get using vegetative propagation in production of oranges (10 mks)

29. (a) Explain ten roles of a farm manager in agricultural production (10 mks)

(b) Describe five roles of agricultural based women groups in farming (5 mks)

(c) Describe land preparation and planting in carrot production (5 mks)

Year 2009 Agriculture Paper 2

Section A (30 marks)

Answer all the questions in this section in the spaces provided

1. Study the table below and fill in the missing words (3 mks)

Description	Cattle	Pigs	Poultry
Young from birth/ hatching to weaning	Chick
Young female before first parturition	Gilt
Mature male for breeding	Bull

2. Name two viral diseases that affect each of the following livestock:

(a) Cattle (1 mk)

(b) Poultry (1 mk)

3. Name one intermediate host for each of the following livestock parasites

(a) Liver fluke (*Fasciola* spp) (½ mk)

(b) Tapeworm (*Taenia* spp) (½ mk)

4. Give four reasons for breeding a lamb on colostrums (2 mks)

5. State four advantages of artificial calf rearing in dairy cattle management

(2 mks)

6. State four harmful effects of tsetse flies (*Glossina* spp) in livestock (2 mks)

7. Why is riddling essential in sheep management (1 mk)

8. Give four reasons for steaming up in dairy cattle management (2 mks)

9. State four limitations of using hydroelectric power on the farm (2 mks)

10. Give two reasons for maintaining a wheelbarrow in good working condition
(1 mk)

11. Differentiate between the following tools

(a) Bastard file and rasp file (1 mk)

(b) Copying saw and hacksaw (1 mk)

12. Name two livestock diseases that are caused by protozoa (1 mk)

13. State four ways of restraining cattle during routine management (2 mks)

14. What is meant by the following terms as used in livestock health:

(a) Incubation period (1 mk)

(b) Mortality rate (1 mk)

15. State two conditions that may inhibit milk let- down during milking

(1 mk)

16. Give four reasons for rearing indigenous cattle in marginal areas of Kenya

(2 mks)

17. Why are the following conditions maintained during artificial incubation of eggs in poultry production?

(a) Proper ventilation (1 mk)

(b) Relative humidity at 60% (1 mk)

SECTION B (20 MKS)

Answer ALL the questions in this section in the spaces provided

18. The diagrams labeled A and B below illustrate two different milking techniques
Study them and answer the questions that follow

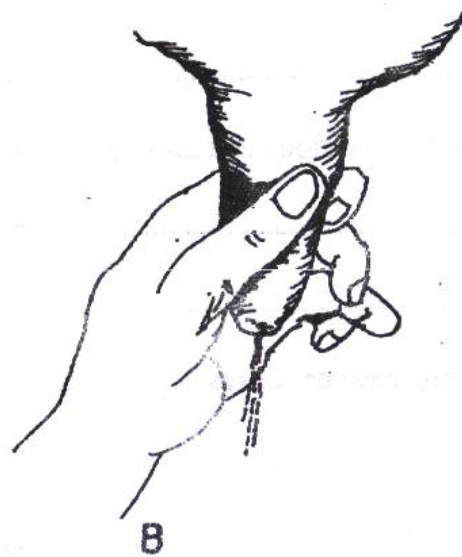

(a) Identify the appropriate techniques for milking

(1 mk)

(b) Describe the procedure of milking technique in (a) above

(2 mks)

(c) State two disadvantages of using a wrong milking technique

(2 mks)

19. The diagram below is an illustration of an egg. Study it carefully and answer the questions that follow.

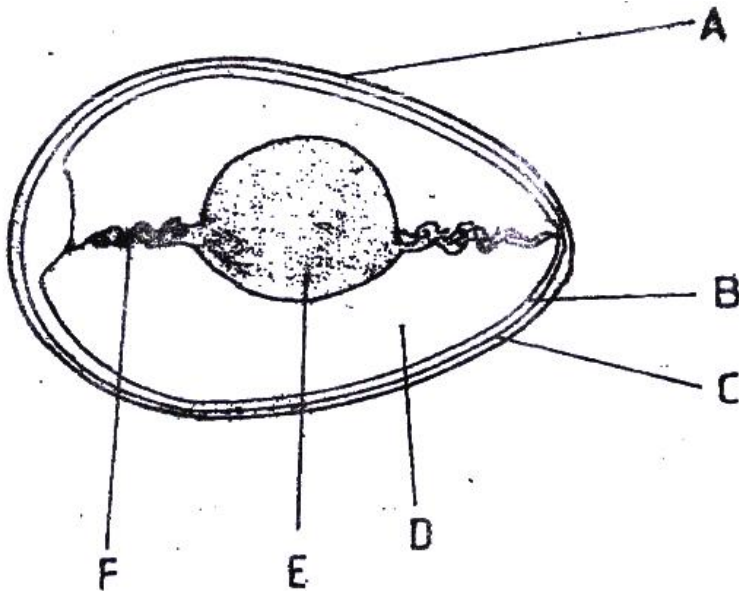

(a) Name the parts labelled B, C, D and F (½ mk)

B (½ mk)

C (½ mk)

D (½ mk)

F (½ mk)

(b) State two qualities of the part labeled A that should be considered when selecting eggs for incubation (2 mks)

(c) What is the function of the part labelled E in a fertilized egg? (1 mk)

20. The diagram below illustrates a hoof of a sheep. Study it carefully and answer the questions that follow



(a) Name the routine management practice that should be carried out on the hoof illustrated above

(1 mk)

(b) State two reasons for carrying out the management practice in (a) above

(2 mks)

21. The following diagram illustrates a symptom of a disease in poultry. Study it carefully and answer the questions that follow.

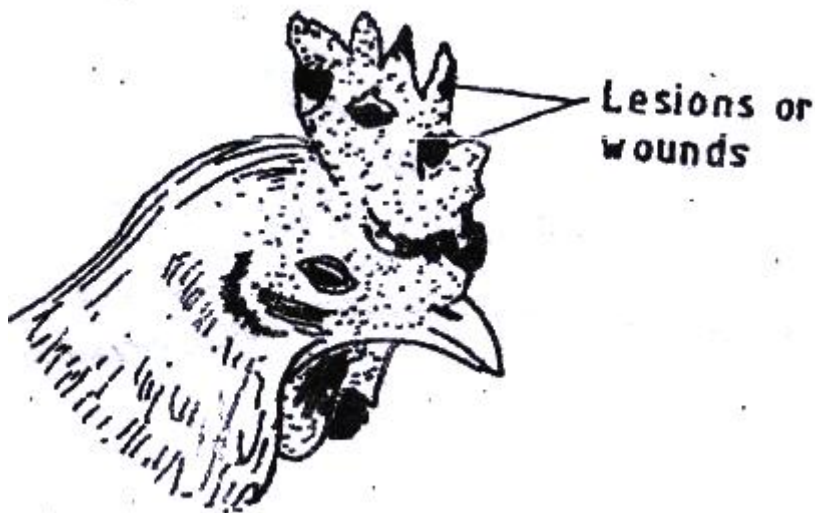

(a) Identify

(i) The disease; (½ mks)

(ii) The causal organism (½ mks)

(b) Apart from lesions, state two other symptoms of the disease (2 mks)

(c) State two control measures for the disease (2 mks)

22. Below is an illustration of livestock management equipment. Study the diagram and answer the questions that follow.

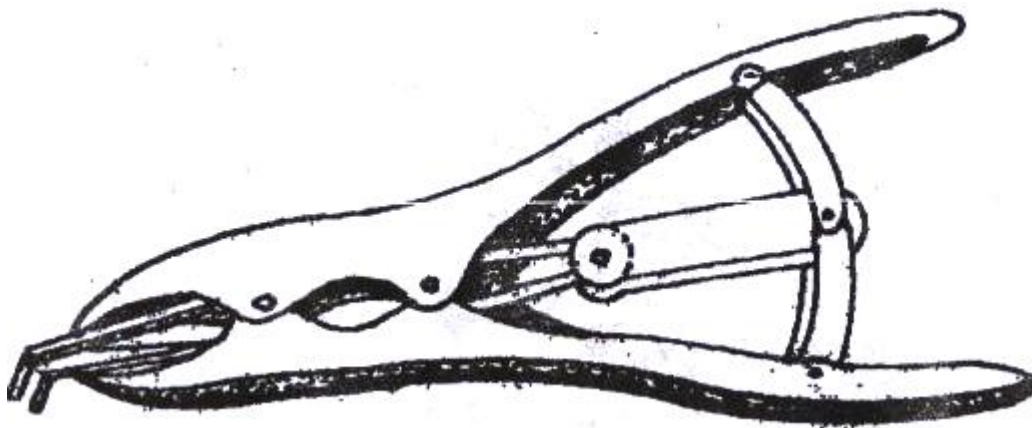

(a) Identify the equipment

(1 mk)

(b) State the use of the equipment

(1 mk)

SECTION C (40 MARKS)

Answer any TWO questions from this section in the spaces provided after questions 25

23. (a) Describe ten signs of ill-health in livestock (10 mks)
- (b) Describe the process of digestion in the following sections in the alimentary canal of a non-ruminant animal:
- (i) Mouth; (1 mk)
 - (ii) Stomach (3 mks)
 - (iii) Small intestines (6 mks)
24. (a) Outline five benefits of using biogas as a source of power on the farm (5 mks)
- (b) Give five advantages of using a sub soiler in seedbed preparation (5 mks)
- (c) Explain five factors that a farmer should consider when sitting a bee hive to prevent swarming of bees (10 mks)
25. (a) Describe the life cycle of a named tapeworm (Taenia spp) (10 mks)
- (b) Describe the process of egg formation in the reproduction system of hen (10 mks)

K.C.S.E YEAR 2010 PAPER 1

SECTION A (30 marks)

Answer *all* the questions in this section in the spaces provided.

- 1 Give **two** disadvantages of intensive system of fanning. (1 mark)
- 2 List **four** methods of farming. (2 marks)
- 3 Give the meaning of the following terms:
 - (a) Nitrogen fixation into the soil; (1 mark)
 - (b) Phosphorus fixation in loss of soil fertility. (1 mark)
- 4 Give **four** reasons-for keeping livestock health records on the farm. (2 marks)
- 5 Explain the relationship between scarcity and choice as used in agricultural economics. (2 marks)
- 6 State two reasons for land fragmentation in Kenya. (1 mark)
- 7 Give **four** advantages of individual owner operator tenure system as practised in Kenya. (2 marks)
- 8 State **four** features that should be considered when choosing water pipes for use on the farm. (2 marks)
- 9 Give **four** reasons for treating water for use on the farm. (2 marks)
- 10 Name **four** statutory boards that are involved in the marketing of crop produce in Kenya. (2 marks)
- 11 State **four** marketing functions of Kenya Co-operative Creameries (K.C.C.). (2 marks)
- 12 Give **two** reasons for carrying out each of the following operations in land preparation:
 - (a) rolling; (1 mark)
 - (b) levelling. (1 mark)
- 13 Name **three** recommended practices that should be carried out when clearing the bush during land preparation. (1 ½ marks)
- 14 State **five** advantages of zero grazing. (2 ½ marks)
- 15 Give **four** factors that would determine the stage at which a crop is harvested. (2 marks)
- 16 Name **two** classes of weeds on the basis of each of the following:
 - (a) growth cycle; (1 mark)
 - (b) plant morphology (1 mark)

SECTION B (20 marks)

Answer *all* the questions in this section in the spaces provided.

Below is a diagram of a weed. Study the diagram carefully and answer the questions that follow.

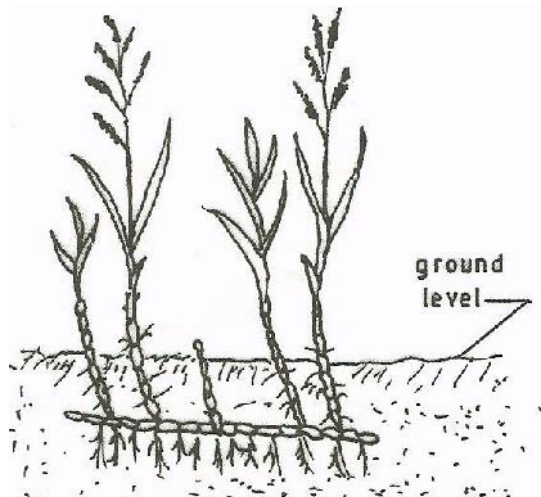

- (a) Identify the weed illustrated above. (1/2 mark)
 (b) Why is the weed illustrated above difficult to control? (1 marks)
 (c) State **four** ways in which the weed can be controlled in a field of maize. (2 marks)

18. The table below shows pH values of different soil samples. Study it and answer the questions that follow.

<u>Soil Sample</u>	<u>pH value</u>
S ₁	3
S ₂	4
S ₃	5
S ₄	6
S ₅	7
S ₆	8
S ₇	9
S ₈	10

- (a) Which soil sample has the highest acidity? (1/2mark)
 (b) State **two** ways in which the pH value of sample S can be lowered. (1 mark)
 (c) Which of the above soil samples is suitable for growing tea? (1/2

mark)

19 Explain how agro forestry tree seeds should be prepared after collection in readiness for planting. (4 marks)

20. (a) The diagrams below represent two ways in which a crop was pruned. Study them carefully and answer the questions that follow.



- (i) Which diagram represents the correct way of pruning? (1/2 mark)
 (ii) Give a reason for your answer in (i) above. (1 mark)
 (b) State **two** ways in which pruning assists in controlling crop diseases. (1 mark)

21 On 1st January 2009, Kaburu Farm started farm operations with Ksh 30,000 cash. During the month, the farm made the following transactions. Study the transactions and prepare a cash analysis for Kaburu Farm for the month of January. (5 VT. marks)

<u>Date</u>	<u>Transaction</u>	<u>Amount (Ksrri)</u>
05/01/09	Livestock sales	80,000
08/01/09	Crop sales	50,000
15/01/09	Bought seed for planting	7,500
20/01/09	Paid K.F.A. for fertilizer	16,400
25/01/09	Bought livestock feeds	50,000
30/01/09	Paid wages for planting & weeding	56,000
31/01/09	Received cash from K.C.C. for milk delivery	120,000

31/01/09

Paid transport charges for milk
delivery

9,000

- 22 (a) What do the figures 18:46:10 on a fertilizer bag represent? (11 marks)
(b) Calculate the quantity of filler materials in the fertilizer in (a) above. (1 mark)

SECTION C (40 marks)

Answer any two questions in this section in the spaces provided after question 25.

- 23 (a) Explain eight factors that can encourage soil erosion. (8 marks)
(b) Describe the seven management practices that should be carried out on a vegetable nursery after sowing seeds until the seedlings are ready for transplanting. (7 marks)
(c) State **five** soil factors that should be considered when selecting a crop to grow in an area
- 24 (a) Outline **five** ways in which high temperature affects agricultural production in Kenya. (5 marks)
- (b) (i) Explain **four** precautions that should be observed when harvesting cotton. (4 marks)
(ii) Describe the harvesting of sugar cane. (3 marks)
(c) Explain **eight** factors that should be considered when planning to set up a farm business. (8 marks)
- 25 (a) Explain **six** physical methods that can be used to control crop pests on the farm. (6 marks)
(b) Describe the production of bulb onions under the following sub-headings:
(i) field management; (4 marks)
(ii) harvesting. (3 marks)
(c) Explain **seven** factors that influence seed rates in crop production. (7 marks)

K.C.S.E YEAR 2010 PAPER 2

SECTION A (30 marks)

Answer all the questions in this section in the spaces provided

- 1 Name the causal agent of anaplasmosis disease in cattle, (1/2 mark)
- 2 List four materials that can be used in constructing a Kenya Top Bar Hive. (2 marks)
- 3 (a) Name two breeds of dairy cattle that originated from the Channel Islands. (1 mark)
(b) Give the distinguishing colour for each of the following breeds of livestock:
 - (i) chinchilla rabbit; (1/2 mark)
 - (ii) toggenburg goat. (1/2mark)
- 4 State four reasons for castration in pig production. (2 marks)
- 5 State **four** characteristics of roughage livestock feeds. (2 marks)
- 6 State two functions of the crop in poultry digestive system. (1 mark)
- 7 State **four** roles of worker bees in a colony. (2 marks)
- 8 Give **four** reasons for controlling livestock diseases. (2 marks)
- 9 State **two** control measures for fowl pox disease in poultry.
- 10 State **one** function for each of the following:
 - (a) shovel; (1/2 mark)
 - (b) strip cup. (1/2mark)
- 11 Give **three** reasons for carrying out maintenance practices on a mower (1 1/2 marks)
- 12 Give **three** limitations of using solar power on the farm. (1/2 marks)
- 13 Why is it important to have a thermostat on a cooling system of a tractor engine? (1 mark)
- 14 Give two advantages of using a disc plough over a mouldboard plough in primary cultivation. (1 mark)
- 15 Name **four** tools that are used when laying concrete blocks during construction of a wall.(2 marks)
- 16 Why is it necessary to have guard rails in a farrowing pen? (1 mark)
- 17 Give **two** reasons for having a footbath in a cattle dip. (1 mark)
- 18 Distinguish between the following practices as used in livestock production;
 - (a) crutching and ringing in sheep management; (2 marks)
 - (b) cropping and harvesting in fish farming. (2 marks)
- 19 Give three ways in which infectious diseases can spread from one livestock to another within a farm. (1 Vi marks)

SECTION B (20 marks)

Answer all the questions in this section in the spaces provided,

- 20 The following illustrations show the behaviour of chicks in a brooder. Study them carefully and answer the questions that follow.

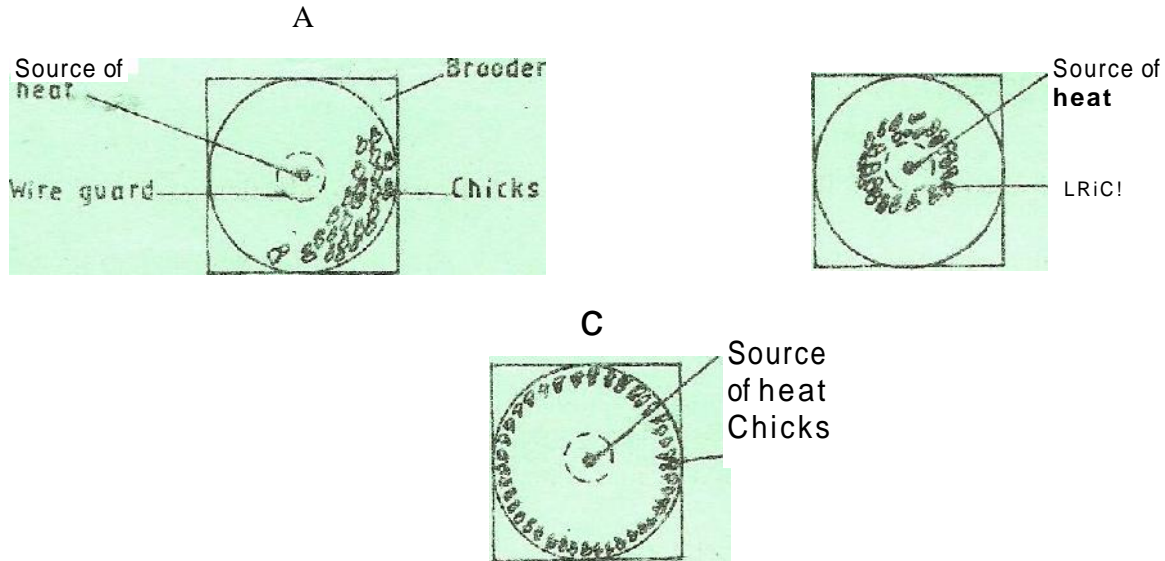

- (a) Explain the cause of behaviour observed in chicks for each of the illustrations labeled A, B and C. (3 marks)
- (b) Give a reason for making the brooder wail round in shape. (1 mark)
- 21 The diagram below shows the reproductive system of a cow. Study it carefully and answer the questions that follow.

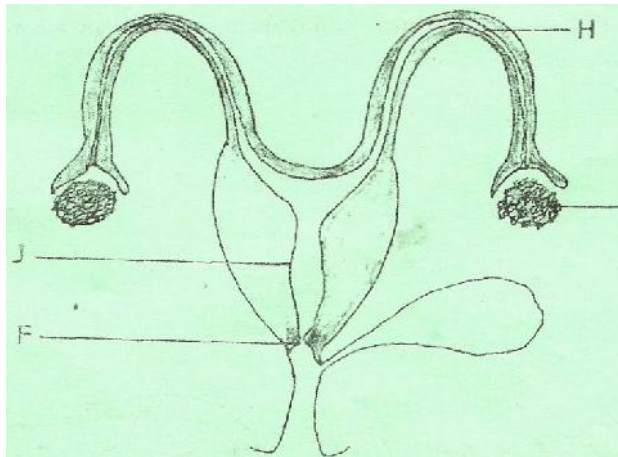

- (a) Name the parts labelled F and H, (2 marks).
- (b) Give **two** functions of the part labelled G (2 marks).
- (c) **Give** the role of the part labelled J. (2 marks)

Below are diagrams of internal parasites. Study them carefully and answer the questions that follow.

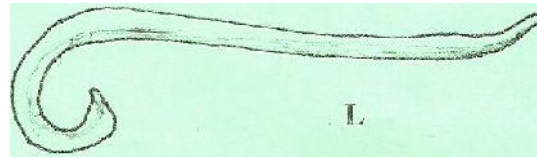
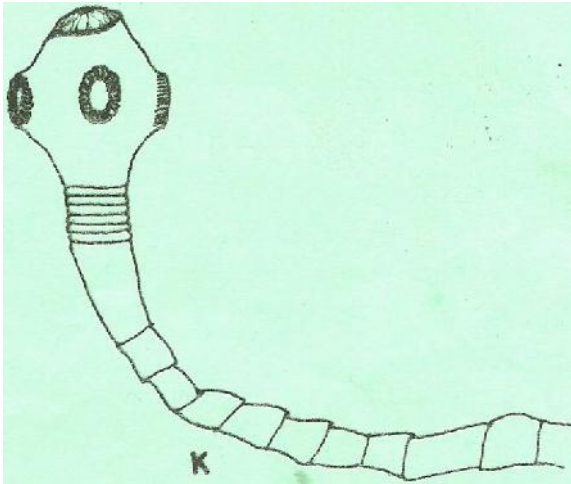

- (a) Identify the parasites labelled K and L. (1/2 mark)
- (b) Name the developmental stage of the parasite labelled K in cattle muscles. (2 1/2 marks)
- (c) Outline the procedure of handling a heifer when administering a liquid deworming drug to control the parasites illustrated above. (1/2 mark)
- 23 Below is a diagram of a farm structure for storing grains. Study it carefully and answer the questions that follow.

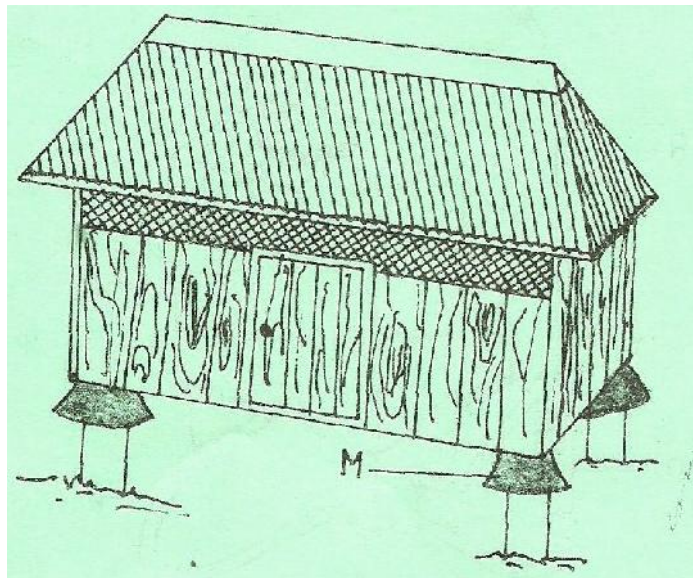

- (a) Identify the farm structure illustrated above. (1/2 mark)
- (b) State the function of the part labelled M. (1 mark)
- (c) State two maintenance practices that should be carried out on the farm structure illustrated above in readiness for grain storage. (1 mark)

23. Below is a diagram of a knapsack sprayer. Study it carefully and answer the questions that follow.

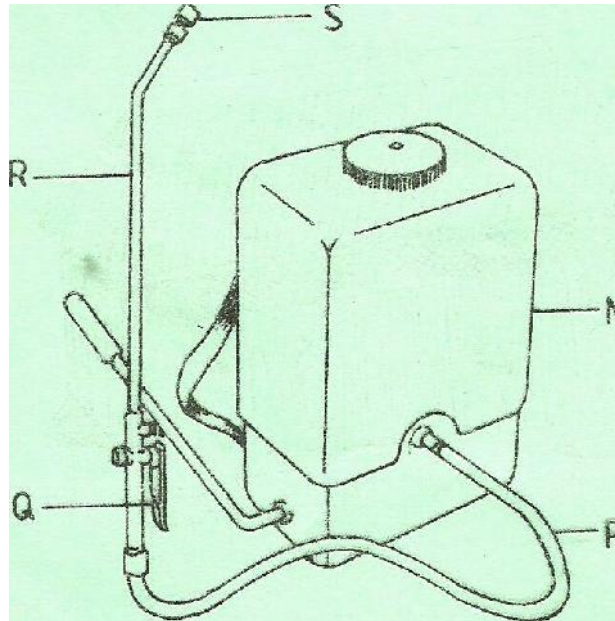

- (a) Name the parts labelled N, P, Q and R.(2 marks)
- (b) State one function of the part labelled S(1 mark)

25. The diagram below illustrates the general shape of a cattle breed. Study it carefully and answer the questions that follow.

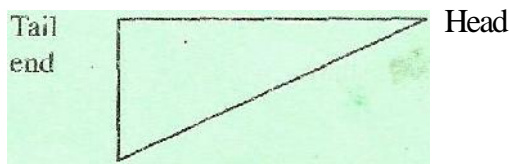

- (a) Identify the type of breed illustrated by the above shape (1/2 mark)
- (b) Give an example of a breed in (a) above. (1/2 mark)
- (c) State four physical characteristics of the type of breed identified in (a) above.(2 marks)

SECTION C (40 marks)

Answer any **two** questions from this section in the spaces provided after question 28.

- 26 (a) Outline **five** advantages of artificial insemination in cattle management. (5 marks)
- (b) Describe **ten** signs of trypanosomiasis (Nagana) disease in livestock. (10 marks)
- (c) Explain **five** functions of water in nutrition. (5 marks)
- 27 (a) State the function of any **six** parts of a zero grazing unit in dairy farming. (6 marks)
- (b) Explain how the power transmitted from a tractor engine is made available for use on the farm under the following subheadings:
 - (i) propeller shaft; (2 marks)
 - (ii) power take off (P.T.O) shaft; (2 marks)
 - (iii) hydraulic system. (2 marks)

- (c) Explain **eight** ways in which ticks can be controlled on a livestock farm. (8 marks)
- 28 (a) Describe **ten** physical characteristics a poultry farmer would use to identify poor layers from a flock of hens. (10 marks)
- (b) (i) Outline **three** characteristics of clean milk. (3 marks)
- (ii) Explain **seven** factors that affect milk composition in dairy fanning. (7 marks)

2011

THE KENYA NATIONAL EXAMINATIONS COUNCIL

Kenya Certificate of Secondary Education

AGRICULTURE

Paper 1

2 hours

SECTION A (30 marks)

Answer all the questions in this section in the spaces provided.

- 1 (a) Name two field management practices that are carried out to obtain optimum plant population in a crop field. (1 mark)
- (b) Explain how each of the practices named in (a) above achieves optimum plant population. (1 mark)
2. Give two examples for each of the following types of costs incurred in broiler production.
- (a) variable costs; (1 mark)
- (b) fixed costs. (1 mark)

State four disadvantages of mono cropping in crop production. (2 marks)

Give three reasons for early seedbed preparation. (1 ¹/₂ marks)

State two ways in which crop rotation controls weeds. (1 mark)

Outline four qualities of a mother plant from which vegetative propagation materials should be obtained. (2 marks)

7 Give three factors that should be considered when choosing the type of labour to use on the farm. (1¹/₂ marks)

8 State the use of each of the following in farm accounting:

(a) balance sheet; (1/2 mark)

(b) inventory; (1/2 mark)

(c) cash book. (16 mark)

9 State four functions of Agricultural Society of Kenya (A.S.K.). (2 marks)

10 How does leaching lead to loss of soil fertility? (1/2 mark)

11 Give two reasons for imposing quarantine on imported planting materials. (1 mark)

12 State four ways of controlling bean anthracnose disease.

13 List four post-harvest practices that are carried out in maize production. (2 marks)

- 14 Name two types of non-competitive markets. (1 mark)
- 15 Name four settlement schemes that the Kenyan government started as a result of the success of the Million Acre Scheme. (2 marks)
- 16 Give a weed for each case, which has the following effect on cattle:
- (a) Poisoning; (1/2 mark)
- (b) Tainting milk when eaten before milking. (1/2 mark)
- 17 Apart from training and extension services, state four other agricultural support services the Kenyan government provides to a maize farmer. (2 marks)
- 18 State three methods of harvesting trees in agroforestry. (1/2 marks)

- 19 Give three maintenance practices for trees in agroforestry. ($\frac{1}{2}$ marks)

SECTION B (20 marks)

Answer all the questions in this section in the spaces provided,

20. The diagram below illustrates a seed potato prepared for planting. Study it carefully and answer the questions that follow:



- (a) Name the practice used in preparing the seed potato above for planting. (1 mark)
- (b) Describe the procedure followed in preparing seed potatoes for planting. (3 marks)
- 21 The diagrams below show a set up of an experiment to study an aspect of soil. The set up was left undisturbed for five hours. Study it and answer the questions that follow.

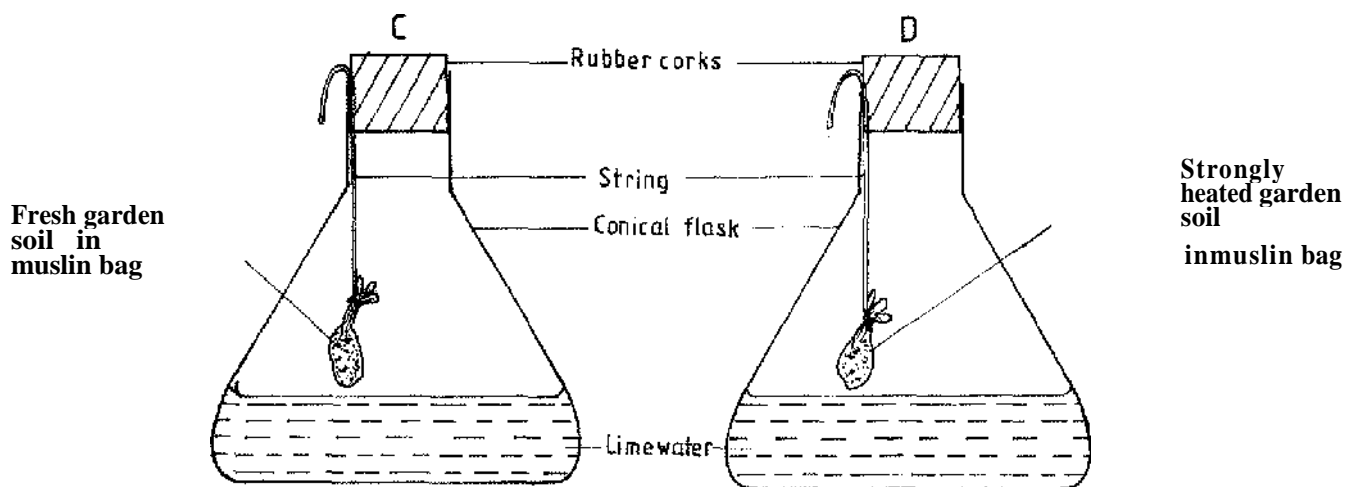

- (1 mark)
- (a) What was the aim of the experiment?

(b) State one observation that was made in each of the flasks labelled C and D.
 C..... (1/2 mark)

D..... (1/2 mark)

(c) Give a reason for each of your answers in (b) above.
 C..... (1 mark)

D..... (1mark)

22 Below is a graphical representation of a law in agricultural economics. Study the graph carefully and answer the questions that follow:

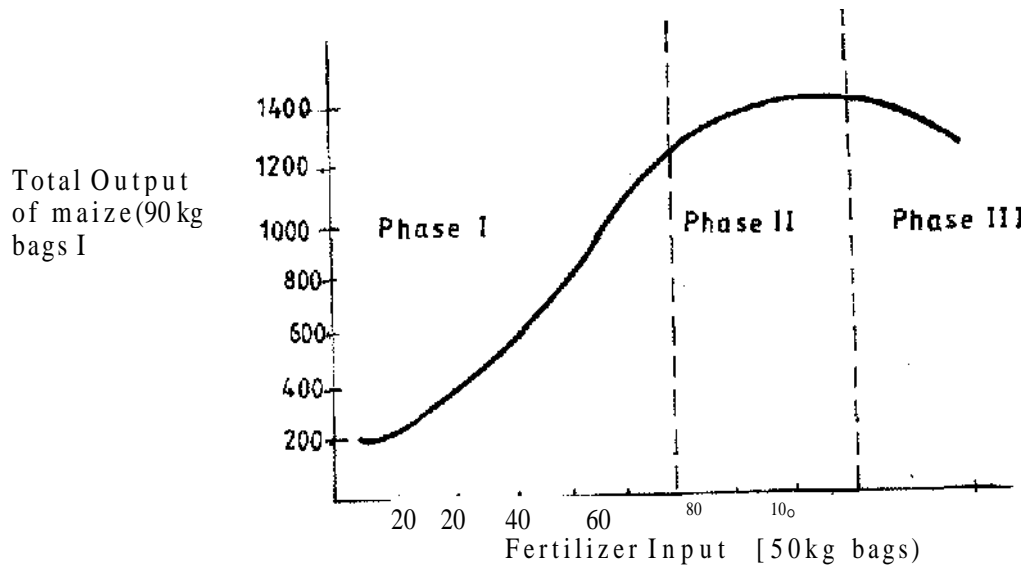

(a) Identify the law illustrated by the graph.

(b) Explain how each additional unit of fertilizer input relates to the total output of maize in phases II and III.

Phase II..... (1 mark)

Phase III..... (1 mark)

(c) State the importance of the law identified in (i) above to the maize farmer. (1 mark)

23 The following information was extracted from Makueni Farm Records for the financial year ending on 30th June 2009. Study it and prepare a profit and loss account for the farm.

(3 marks)

• Rent received	Sh. 10,000
• Egg sale	Sh. 60,000
• Repair of tractor	Sh. 30,000
• Opening valuation	Sh. 80,000
• Interest on Bank loan	Sh. 20,000
• Tax paid	Sh. 40,000
• Closing valuation	Sh. 90,000
• Purchase of farm inputs	Sh. 90,000
• Debts receivable from fanners co-op society	Sh. 100,000
• Maize sales	Sh. 55,000

24 The diagram below illustrates a grazing system. Study it carefully and answer the questions

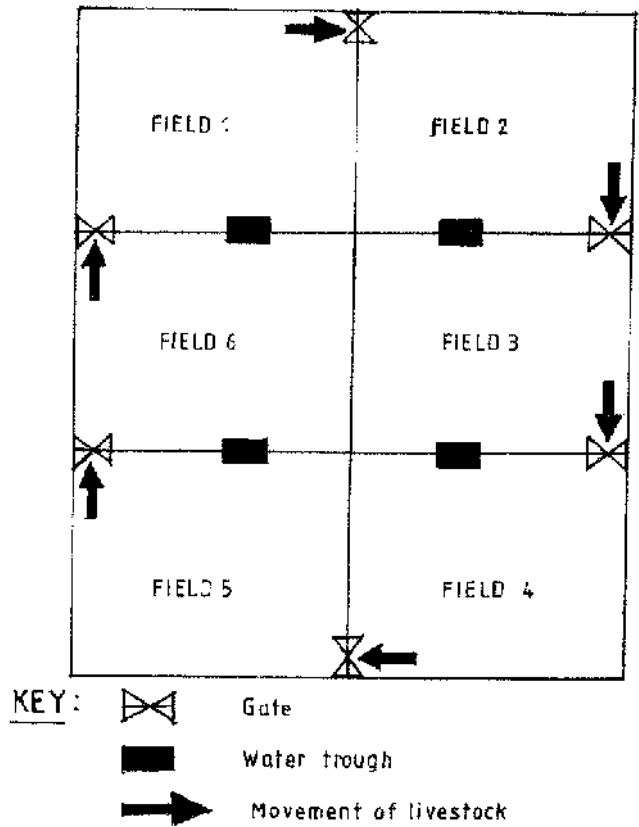

that follow

- (a) Identify the grazing system illustrated above. (1/2 marks)
- (b) State five advantages of the grazing system illustrated above. (3 marks)

25 The diagram below is an illustration of a weed. Study it and answer the questions that follow.



(a) Identify the weed. (1/2 marks)

(b) State two harmful effects of the weed illustrated above. (2 marks)

SECTION C (40 marks)

Answer any two questions from this section in the spaces provided after question 28.

26 (a) Describe how water is treated to remove solid impurities.

(

5 marks)

(b) Give a reason for each of the farm records kept on a dairy farm.

(

5 marks)

(c) Describe the production of cabbages under the following sub-headings:

(i) seedbed preparation;

(

3 marks)

(ii) transplanting of seedlings.

(7 marks)

27 (a) Describe the effects of pests on maize in the field.

(

6 marks)

(b) (i) Describe the procedure of harvesting pyrethrum.

(

4 marks)

(ii) Explain the precautions that should be observed during the harvesting of pyrethrum. (3 marks)

(c) Describe the cultural methods of controlling soil erosion.

(

7 marks)

28 (a) Explain five ways in which biotic factors influence crop production in agriculture.

(5 marks)

(b) Describe how the stem cuttings for propagating tea are prepared.

(

9 marks)

(c) Describe the properties of nitrogenous fertilizers.

Agriculture paper 2 2011

SECTION A 30 marks)

Answer all the questions in this section in the spaces provided.

1. State **four** maintenance practices for a disc plough. (2 marks)

2. Name three methods that are used in selection of breeding stock in livestock production. (1½ marks)

3. State four advantages of using animals instead of tractors as a source of power on the farm. (2 marks)

4. Name one livestock disease that is transmitted by each of the following parasites:
 - (a) blue ticks; (½ marks)

 - (b) brown ear ticks; (½ marks)

 - (c) tsetse flies. (½ marks)

5. State four methods of controlling round worms (*Ascaris sp*) in livestock. (2 marks)

6. Give the meaning of the following terms as used in livestock health:
 - (a) disease; (1 mark)

- (b) vaccination. (1 mark)
- 7 State three maintenance practices for a tractor battery. (1½ marks)
- 8 Name the type of breed into which each of the following breeds of cattle are classified:
- (a) Aberdeen Angus; (½ marks)
- (b) Guernsey; (½ marks)
- (c) Sahiwal; (½ marks)
- (d) Redpoll. (½ marks)
9. Give **two** ways in which proper nutrition helps to control livestock diseases. (1 mark)
- 10 List **four** categories of livestock diseases. (2 marks)
- 11 Name **two** breeding systems that can increase the frequency of **high milk** production genes in indigenous cattle. (1 mark)
- 12 Name **two** bloodless methods of castration in lambs. (1 mark)

13 Give the meaning of the following terms as **used in** livestock breeding:

(a) recessive gene;

(1 mark)

(b) epistasis.

(1 mark)

14 State four signs that indicate that a doe is about to kindle.

(2 marks)

15 Name two developmental stages of a liverfluke (*Fasciola sp.*) which occur in the fresh water snail (*Limnaea sp.*).

(1 mark)

16 Name the strokes in a four stroke cycle engine.

(2 marks)

17 State four signs of mite attack in poultry.

(2 marks)

18 State three advantages of natural feeding in calf rearing.

(1½ marks)

SECTION B (20 marks)

*Answer **all** the questions in this section in the spaces provided.*

- 19 A dairy farmer is required to prepare 100 kg of dairy meal containing 20% Digestible Crude Protein (D.C.P.). Using the Pearson's Square Method, calculate the quantity of soya bean (40% **D.C.P.**) and rice (16% D.C.P.) the farmer requires for the dairy meal. (4 marks)

- 20 Below is an illustration of a camel. Study it and answer the questions that follow.

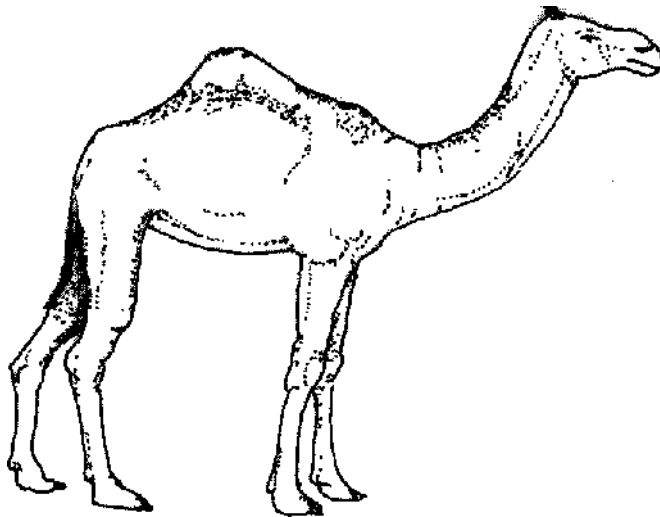

- (a) Identify the camel species illustrated above. ($\frac{1}{2}$ marks)
- (b) Name **three** products that farmers obtain from the camel species illustrated above. ($1\frac{1}{2}$ marks)

- (c) Give two reasons why the camel species illustrated above is able to survive in its natural habitat. (2 marks)

21 The diagram below represents farm tools and equipment. Study them and answer the questions that follow.

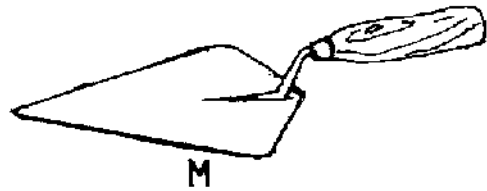
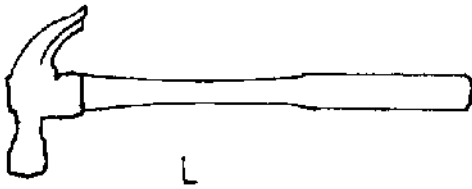
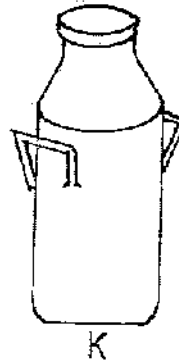
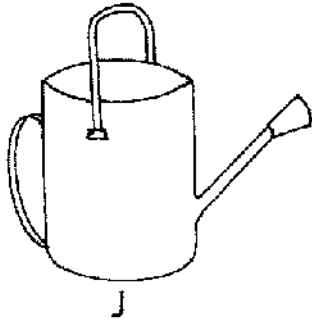

(a) Identify the tool / equipment labelled **J**, **K** and **M**. **K**.

J (1/2 marks)

K (1/2 marks)

M (1/2 marks)

(b) State one use for each of the tool / equipment labelled **K** and **L**.

K (1 mark)

L (1 mark)

(c) Give two maintenance practices for the equipment labelled **K**. (1 mark)

22 The illustration below shows a practice carried out to prevent mastitis infection in a dairy cow.

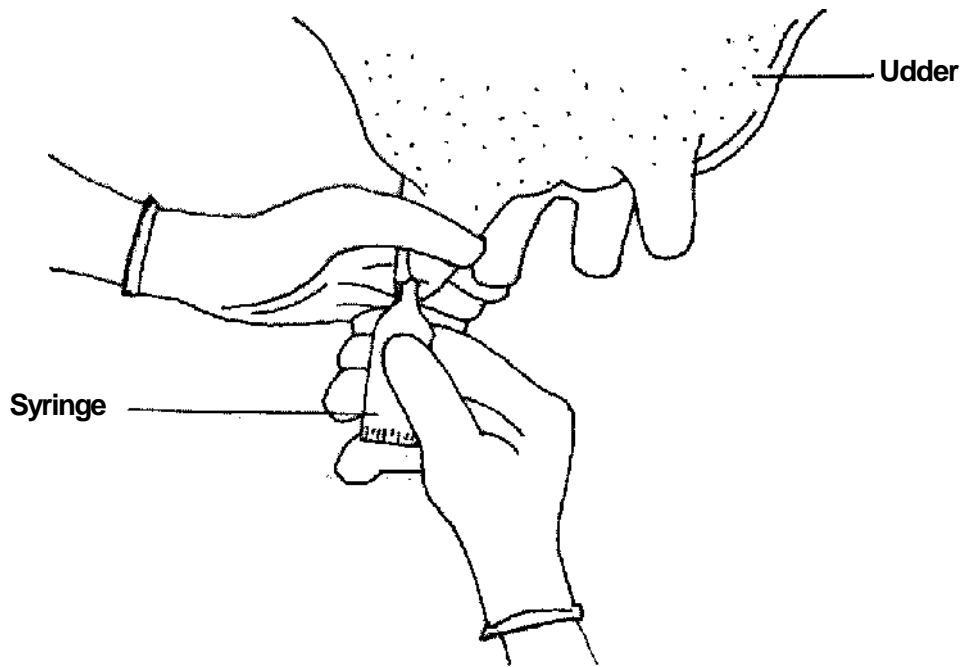

(a) Identify the practice. (1½ marks)

(b) At what stage is the practice carried out? (1½ marks)

- (c) State two other practices that are carried out on the udder to prevent mastitis infection. (2 marks)

23 The diagram below shows the digestive system of cattle. Study it and answer the questions that follow.

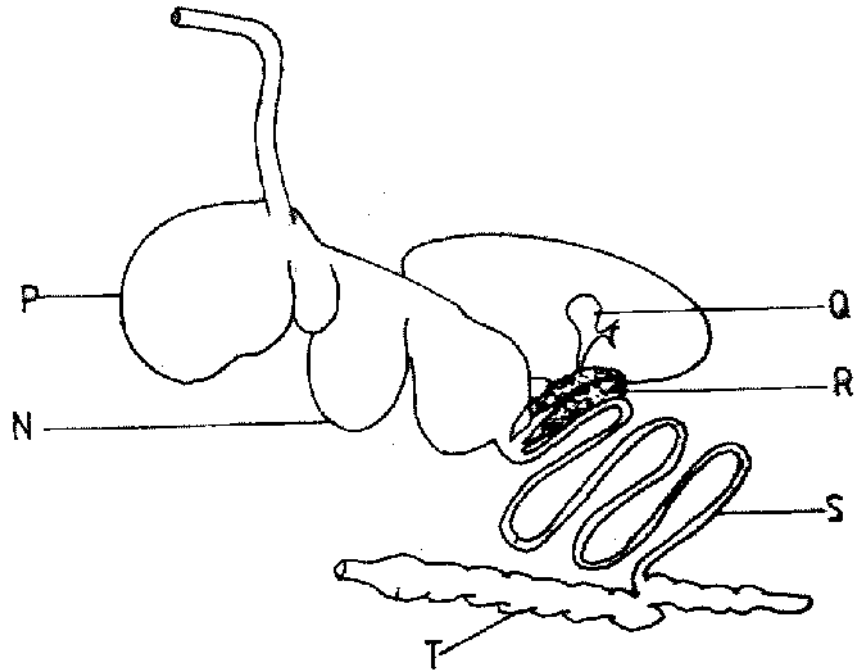

(a) Name the parts labelled N, P and Q.

N (1/2 marks)

P (1/2 marks)

(b) State one function for each of the parts labelled S and T.

S..... (1 mark)

T (1 mark)

(c) Give one enzyme produced by each of the parts labelled **R** and **S**.

R ($\frac{1}{2}$ marks)

S ($\frac{1}{2}$ marks)

SECTION C (40 marks)

Answer any two questions from this section in the spaces provided after question 26.

24 (a) Explain the factors considered when culling livestock. (5 marks)

(b) Describe poultry management under the following sub-headings:
(i) causes of stress; (8 marks)

(ii) control measures for cannibalism. (7 mark)

- 25 (a) Describe the feeding practices in artificial rearing of a dairy calf, (10 mark)
- (b) Describe Newcastle disease under the following sub-headings
- (i) causal organism; (1 mark)
- (ii) signs of infection; (7 mark)
- (iii) control measures. (2 marks)
26. (a) Describe the uses of fences on the farm. (10 marks)
- (b) Give five harmful effects of liver flukes in sheep rearing. (5 mark)
- (c) State the differences between a diesel engine and a petrol engine. (5 mark)

AGRICULTURE PAPER 1

2012 QUESTIONS

SECTION A (30 marks)

Answer ALL the questions in this section in the spaces provided.

- 1 Name the part harvested for each of the following crops:
 - (a) onions (½ marks)
 - (b) carrots (½ marks)
 - (c) coffee (½ marks)
2. State **four** biotic factors that influence crop production. (2 marks)
3. Name **four** methods of controlling crop pests. (2 marks)
4. State **four** ways of harvesting water on the farm. (2 marks)
5. Name **four** farm records that should be kept by a poultry farmer. (2 marks)
6. State **four** disadvantages of using organic manure in crop production. (2 marks)
7. Give **two** ways in which pastures are classified. (1 mark)
8. State **four** disadvantages of organic mulches. (2 marks)
9. Give **five** advantages of practicing crop rotation. (2 ½ marks)
10. State **two** advantages of earthing up in crop production. (1 mark)
- 11 Give **four** harmful effects of weeds on crop production. (2 marks)
- 12 State **three** advantages of shifting cultivation. (1 ½marks)
- 13 Give **five** advantages of zero grazing in dairy farming. (2½ marks)
14. State **four** factors that determine the stage at which a crop is harvested. (2marks)
15. State **four** ways in which land reform can be implemented in Kenya. (2marks)
16. Give **four** factors that influence the number of secondary cultivation in seedbed preparation. (2marks)

SECTION B

Answer all the questions in this section in the spaces provided.

17. The illustration below shows a structure used for controlling soil erosion. Study it carefully and answer the questions that follow;

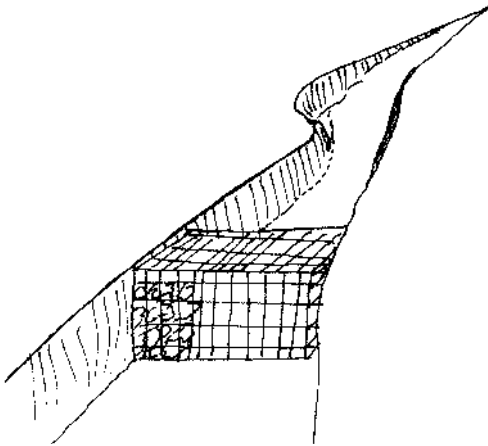

- a) Identify the structure (1mark)
- b) Explain two ways in which the structure helps to control soil erosion. (2marks)
18. The diagram below illustrates the law of demand in agricultural marketing. Study it and answer the questions that follow.

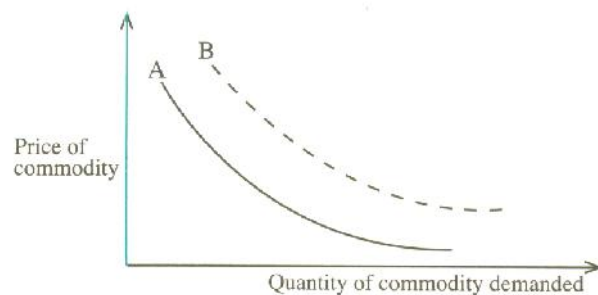

- a) Give a reason for the shape of the curve labelled A. (1mark)
- b) If the price of the commodity remains constant, explain three factors that can cause the curve to shift from A to B. (3marks)

19. The diagrams below illustrates common weeds in arable land. Study them carefully and answer the questions that follow.



- Identify the weed labelled D. (1mark)
- Classify the weed labelled C according to plant morphology. (1mark)
- Give one reason why it is difficult to control the weed labelled D. (1mark)

20. The diagram below illustrates an agroforestry practice. Study it and answer the questions that follow.



- Identify the agroforestry practice illustrated above. (1mark)
- Explain three benefits of the practice illustrated above. (3marks)

21. The diagram below shows a pest and the damaged crop. Study it and answer the questions that follow;

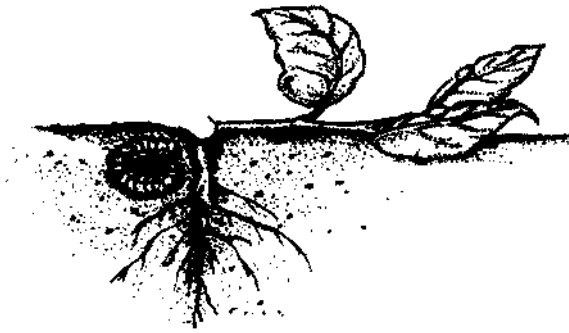

- a) Identify the crop pest illustrated above. (1mark)
- b) Explain two ways of controlling the pest (2marks)
22. The diagram below illustrates an investigation on a property of soil using soil samples labelled J,K and L.

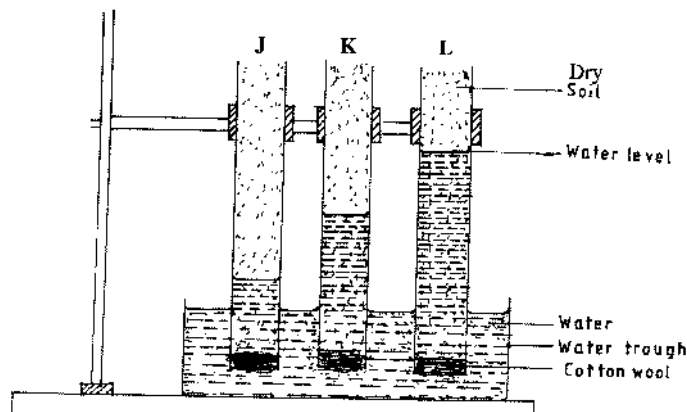

- a) If the levels of water shown in the diagram were observed after three hours, name the property of soil being investigated. (1mark)
- b) What is the relationship between the soil property named in (a) above and the size of soil particles? (1mark)
- c) Which soil sample would be suitable for growing paddy rice? (1mark)

SECTION C (40 marks)

Answer any TWO questions from this section in the spaces provided after question 25.

- 23 (a) Explain **five** factors that should be considered in farm planning. (10 marks)
- (b) Describe the transplanting of tomato seedlings. (10 marks)
- 24 (a) Explain **five** factors that should be considered when siting a vegetable nursery. (5 marks)
- (b) Explain six factors that should be considered when selecting seeds for planting. (6 marks)

- (c) Explain the different ways in which each of the following environmental factors influence crop production:
- (i) temperature; (4 marks)
 - (ii) wind. (5 marks)
- 25** (a) Outline the information contained in a Purchase Order. (5 marks)
- (b) Describe the harvesting of tea. (6 marks)
 - (c) Explain the importance of irrigation in crop production. (5 marks)
 - (d) Describe the role of magnesium in crop production. (4 marks)

AGRICULTURE PAPER 2

2012 QUESTIONS

SECTION A (30 marks)

Answer ALL the questions in this section in the spaces provided.

1. Apart from hides and skins, name the raw material obtained from each of the following livestock for the textile industry:
 - (a) goat..... (½ mark)
 - (b) sheep..... (½mark)
 - (c) rabbit..... (½ mark)
2. Give **three** reasons for candling eggs in poultry production. (1½ marks)
3. Name **two** nutritional diseases of cattle. (1 mark)
4. State **two** advantages of housing calves singly in cattle management. (1 mark)
5. Give **four** features of housing that help to control livestock diseases. (2 marks)
6. Name **three** methods of harvesting fish in a pond. (1½ marks)
7. State **five** methods of dehorning in cattle management. (2½ marks)
8. Give the appropriate term that refers to each of the following:
 - (a) castrated chicken (½ mark)
 - (b) young one of a rabbit (½mark)
 - (c) mature male goat. (½mark)
9. Give **three** ways in which farmers market beef cattle in Kenya. (1½ marks)
10. State **four** causes of egg eating in a flock of layers. (2 marks)
11. Name **two** practices that are carried out when preparing ewes for mating. (1 mark)
12. Give **four** reasons for identification in cattle management. (2 marks)

GATEPASS TO SUCCESS

13 State **three** advantages of fold system in poultry rearing. (1½marks)

14 State **four** practices that immediately come after complete milking in a milking shade. (2 marks)

15 The following is a list of livestock diseases:

- brucellosis
- trypanosomiasis
- newcastle
- anthrax
- african swine fever
- black quarter.

Which **two** diseases are

(a) both bacterial and zoonotic? (1 mark)

(b) caused by virus? (1 mark)

16 State **three** functions of a lubrication system on a tractor. (1½ marks)

17 Distinguish between the following terms as used in livestock health:

(a) isolation and quarantine; (2 marks)

(b) curative drug and prophylactic drug. (2 marks)

SECTION B (20 marks)

Answer ALL the questions in this section in the spaces provided.

18 Below are illustrations of farm tools and equipment.

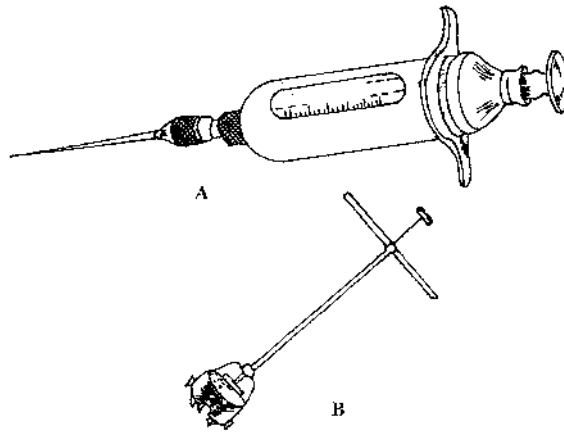

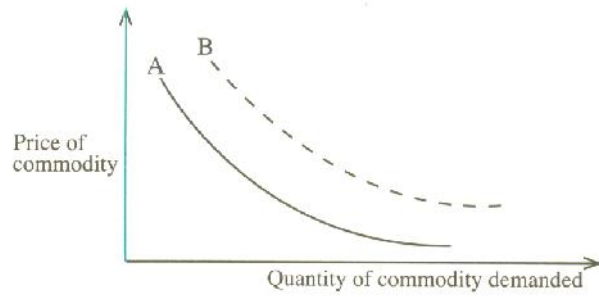

- (a) Identify the tool/equipment labelled **A** and **B**.
- A..... (1 mark)
- B**..... (1 mark)
- (b) State **one** appropriate use of the tool labelled **C**. (1 mark)
- (c) Explain **two** maintenance practices for the tool labelled **D**. (2 marks)

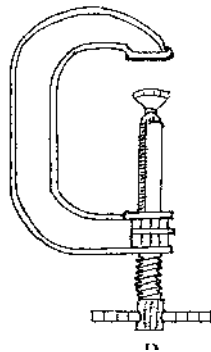
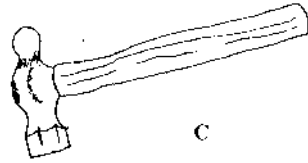

- a) Identify the tool/equipment labelled A and B. (1mark)
A..... (1mark)
B..... (1mark)
- b) State one appropriate use of the tool labelled C. (1mark)
- c) Explain two maintenance practices for the tool labelled D. (2marks)

19. The diagram below illustrates a livestock parasite.

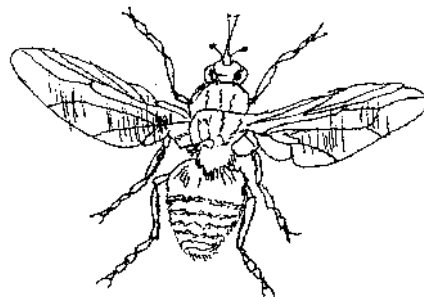

- a) Identify the parasite illustrated above. (1mark)
- b) State the major harmful effect of the parasite. (1mark)
- c) Explain four control measures for the parasite. (4marks)

20. The photograph below illustrates a method of identification labelled X in cattle.

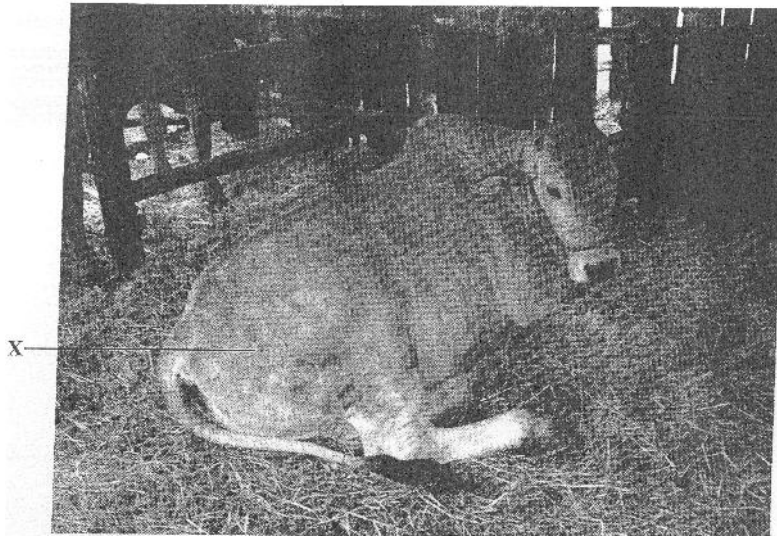

- a) Name the identification method. (1mark)
- b) Explain three disadvantages of the identification method. (3marks)
21. The illustration below shows a cross section of a cattle dip.

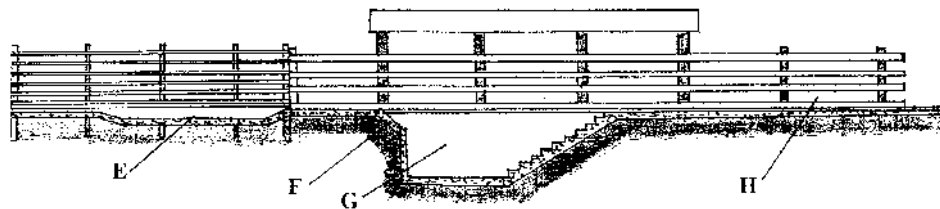

- a) Name the parts labelled E and G.
 E..... (1mark)
 G..... (1mark)
- b) State one use for each of the parts labelled E, F and G. (3marks)
 E.....
 F.....
 H.....

SECTION C (40 marks)

Answer any TWO questions from this section in the spaces provided after question 24.

- 22 (a) Describe the functions of the various types of pens in a piggery unit. (4 marks)
- (b) Describe the control measures for tapeworms (*Taenia spp*) in livestock. (6 marks)
- (c) Giving a relevant example in each case, describe the role of the various components of a balanced diet in livestock nutrition. (10 marks)
- 23 (a) Describe the management of one day old chicks in a brooder until they are eight weeks old. (12 marks)
- (b) Give the reasons why embryo transfer use should be encouraged in dairy cattle breeding. (8 marks)
- 24(a) Describe foot rot disease under the following sub-headings:
- (i) causal organism; (1 mark)
- (ii) signs of infection; (5marks)
- (ii) control measures. (4 marks)
- b) Explain the importance of each of the functional differences between a disc plough and a mouldboard plough in land preparation. (10 marks)