

NAME _____ SCHOOL -----
ADM NO -----
SIGNATURE -----
DATE -----

**233/1
FORM 4
CHEMISTRY
PAPER 1**

TIME: 2 HOURS

SCHOOL BASED FORM 4 EXAMINATION JULY-AUGUST 2017

FORM FOUR

INSTRUCTIONS

1. Write your name and admission number in the space provided above.
2. Sign and write the date of examination in the space provided above.
3. Answer ALL the questions in the spaces in the questions.
4. ALL working must be clearly shown where necessary.
5. KNEC Mathematical tables and silent electronic calculators may be used.
6. Candidates should answer the questions in English language.

For Examiner's use only

Questions	Maximum Score	Candidate's score
1 – 29	80	

1. Draw the structures and give the names of three alkane having molecular formula C_5H_{12} (3mks)

2. The table below shows three isotopes of element neon. Study it and answer the questions that follow;

Mass number of Isotope	Percentage abundance (%)
20	90.9
21	0.3
22	8.8

a) What are isotopes (1mk)

b) Calculate the relative atomic mass of an atom of neon. (2mks)

3. A compound whose formula is $Z(OH)_2$ reacts as shown below;

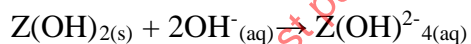
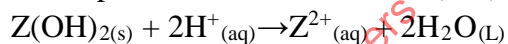

a) State the property exhibited by $Z(OH)_2$ (1mk)

ii) Name two hydroxide that behave like $Z(OH)_2$ (2mks)

4. The diagram below shows sodium metal being dropped in water. Study it and answer the questions that follow;

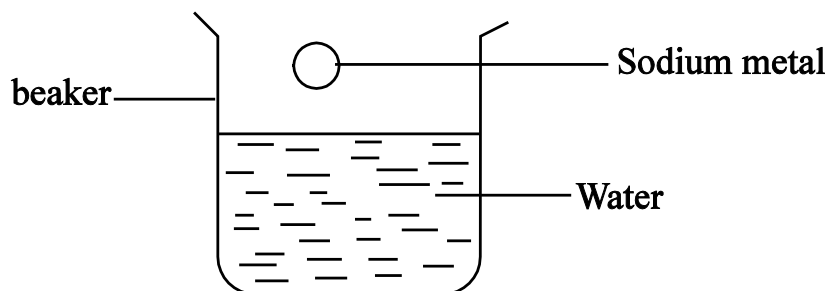

- i) State and explain two observations made during the reaction. (2mks)

- ii) Write an equation for the reaction that takes place during the experiment. (1mk)

5. State two advantages of drinking hard water than soft water. (2mks)

6. A gas occupies 0.4dm^3 at 20°C and 1.0×10^3 Pascals what will be the temperature of the gas when the volume and pressure of the gas is 0.1dm^3 and 1.0×10^3 Pascals respectively. (3mks)

7. (i) On complete combustion of a hydrocarbon 0.88g of carbon (iv) oxide and 0.36g of water were formed (i) calculate the molecular formula of the hydrocarbon given that relative molecular mass of the hydrocarbon is 70. ($\text{C} = 12, \text{H} = 1, \text{O} = 16$) (2mks)

- ii) Draw the structural formula of the hydrocarbon in (i) above (1mk)

8. The table below shows the observations made when aqueous ammonia was added to cations of elements A, B and C until in excess.

Cation of	Addition of a few drops of aqueous ammonia	Addition of excess aqueous ammonia
A	White precipitate	Dissolves to form a colourless solution
B	Pale blue precipitate	Deep blue solution
C	No precipitate	No precipitate

i) Name the cation present in (2mks)

i) A -

ii) B -

ii) Write the formula of ion present in the deep blue solution, (1mk)

9. The equation below shows the oxidation of sulphur (IV) oxide to sulphur (VI) oxide

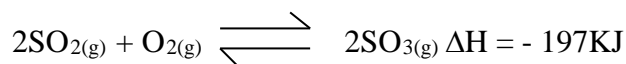

i) Name **two** catalysts for this reaction. (1mk)

ii) State and explain the effect on the yield of sulphur (VI) oxide when;

I pressure is reduced (1mk)

II temperature is reduced (1mk)

10. i) Name the bleaching agent formed when chlorine gas reacts with hot concentrated sodium hydroxide solution. (1mk)
-

ii) Name another use of the compound in (i) above other than bleaching. (1mk)

11. 0.28g of aluminium reacted completely with oxygen gas. Calculate the volume of oxygen used. (molar gas volume is $24000\text{cm}^3 \text{ mol}^{-1}$) (3mks)

12. Describe you would prepare a pure sample of zinc carbonate starting with zinc oxide. (3mks)

13. Equal volumes of 2M monobasic acids D and E were each reacted with excess magnesium ribbon. The table shows the volumes of gas produced after 2 minutes. (4mks)

Acid	Volume of gas (cm^3)
D	30
E	70

- Explain the difference in the volumes of gas produced. (2mks)

14. The thermo chemical equations below shows the formation of hydrogen peroxide under standard conditions;

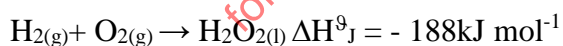
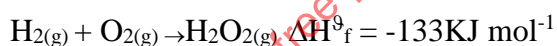

- Calculate the molar heat of vaporization of hydrogen peroxide. (2mks)

15. 50cm^3 of 1M magnesium sulphate was electrolysed using the set up represented by the diagram below;

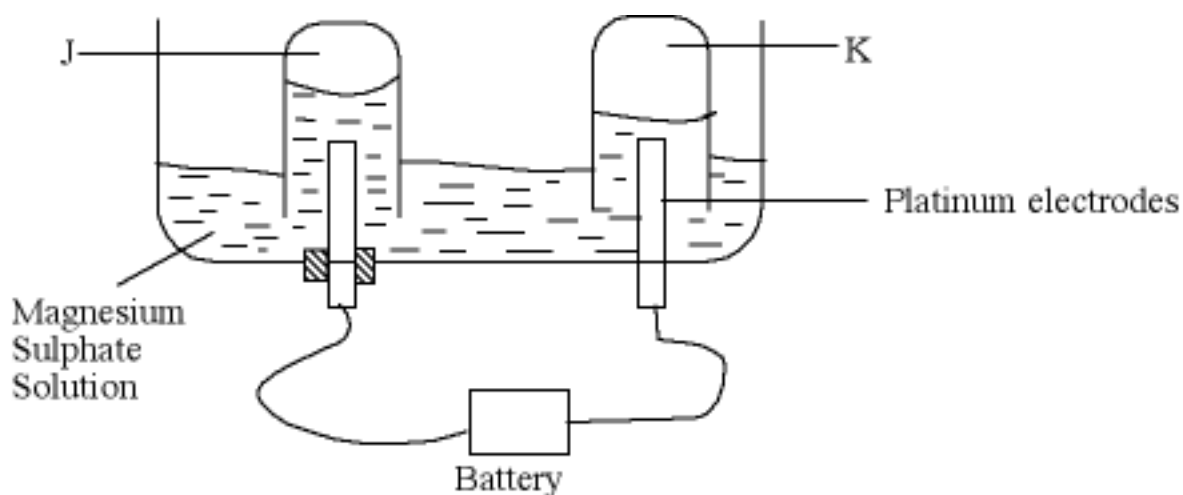

I Identify the gas labeled K. ($\frac{1}{2}$ mk)

II Write an equation for the reaction that liberates gas J. (1mk)

III What happens to the concentration of the magnesium sulphate during electrolysis. Explain ($1\frac{1}{2}$ mk)

16. i) What is the half life? (1mk)

ii) Xg of a radioactive element was reduced to 12.5g in 15.6years. If the half life of the element is 5.2years. Calculate the value of X. (2mks)

17. a) The diagram below shows a structure of water molecules.

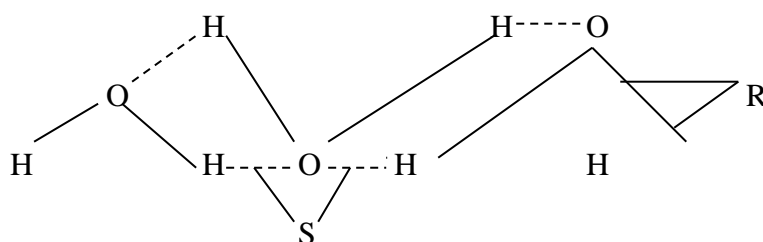

Name the bonds labeled

R - (½mk)

S - (½mk)

b) Using dot (.) and cross (x) diagram sho bonding in;

i) Potassium chloride (K = 19 Cl = 17)

ii) Carbon tetrachloride

C = 6 Cl = 17

18. i) In an experiment to determine solubility of solid P in water at 25⁰C, the following results were obtained.

Mass of empty evaporating dish – 24.2g

Mass of evaporating dish + saturated solution = 40.4g

Mass of evaporating dish + dry solid P = 28.4g

Using the information above calculate the solubility of solid P at 25⁰C in g/100g of water.

(2mks)

ii) State one precaution observed when carrying out the experiment in (i) above 1 (1mk)

19. i) Name two conditions that accelerate rusting. (1mk)

ii) State two ways rusting can be prevented. (2mks)

20. The molecular formula of a hydrocarbon C_7H_{16} . The hydrocarbon can be converted into two other hydrocarbons as shown below by the equation below.

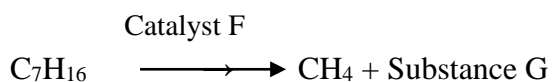

Name i) the process shown by the equation above (1mk)

ii) Catalyst F (1mk)

iii) State one chemical test for substance G (1mk)

21. A solution of bromine in water is a chemical reaction in equilibrium. The reaction involved is represented by the equation below;



State and explain the observation made when concentrated sulphuric (IV) acid is added to the mixture at equilibrium. (2mks)

22. The table below shows solutions and their PH values.

Solution	PH value
L	2.0
M	7.0
N	14.0

i) Select two solutions that will react with calcium metal. Give a reason. (2mks)

ii) Which solution is that of sodium chloride solution? (1mk)

23. During the extraction of aluminium, cryolite is added to molten aluminium oxide.

i) State the function of cryolite during the process (1mk)

ii) Give two reasons why aluminium is used in making overhead cables. (2mks)

24. Study the standard reduction potentials below and answer the questions that follow;

The letters are not actual symbols of the elements

Half cell E⁰/volts



i) Select the element which is the strongest reducing agent. Give a reason. (1mk)

ii) Select two half cells when combined would produce the largest e.m.f (1mk)

iii) Calculate the e.m.f of the electrochemical cell formed when the two half cells in (ii) above are combined. (1mk)

25. State two uses of nitrogen gas. (2mks)

26. When iron filings are added to aqueous copper (II) sulphate solution a reaction takes place. State three observations made during the reaction. (2mks)

27. A colourless solution was suspected to be water. Give one chemical and one physical test that can be used to show that the colourless solution is water. (2mks)

i) Chemical test: - (1mk)

ii) Physical test: - (1mk)

28. Study the table below and answer the question that follow. The letters do not represent the actual symbols of the element.

Formula of ion	Electron configuration
W ²⁺	2
V ²⁻	2.8
X ³⁺	2.8
U ²⁺	2.8
Y ⁻	2.8.8

a) Select elements found in;

i) the same group (1mk)

ii) period three (1mk)

b) What is the family name given the group members to which element Y belongs (1mk)

29. The diagram below represents a paper chromatogram of pure inks marked 1, 2, 3 and 4. 5 is a mixture that contains inks 1 and 4 only.

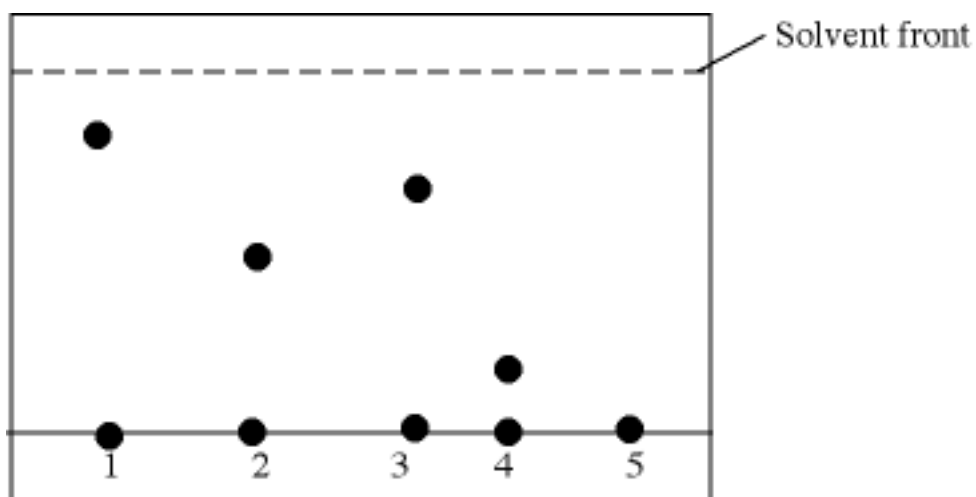

- a) Give a reason why ink 1 moves faster to the solvent front than ink 2. (1mk)
-
- b) Name two factors that determine chromatography. (1mk)
-
- c) Show on the chromatogram diagram the chromatography of K. (1mk)
-

for free past papers visit www.freecsepastpapers.com