

### 3.18 BUILDING CONSTRUCTION (446)

#### 3.18.1 Building Construction Paper 1 (446/1)

#### SECTION A (40 marks)

Answer **all** the questions in this section in the spaces provided.

- 1 Name **two** tools and **two** equipment used for setting out a right angle of a building. (2 marks)
- 2 Describe the following types of foundations and give **two** examples in each case:
- (a) shallow foundations;
  - (b) deep foundations. (5 marks)
- 3 State **four** reasons why clay tiles are not commonly used for roofing. (4 marks)
- 4 List **four** undesirable effects of dampness in buildings. (2 marks)
- 5 (a) Give **four** requirements of a drainage system. (4 marks)
- (b) State the function of a goose neck bend in a cold water service layout. (1 mark)
- 6 (a) State **four** limitations in starting a small business related to building construction. (2 marks)
- (b) Describe the following members of a scaffold:
- (i) standard;
  - (ii) guard rail. (2 marks)
- 7 (a) List **two** requirements for a safety helmet to be worn on a construction site. (2 marks)
- (b) Describe **two** ways through which moisture can penetrate a building. (4 marks)
- 8 Use labelled sketches to show the following features on a wall:
- (a) raking back;
  - (b) tothing. (4 marks)

- 9 (a) Outline the procedure of reconditioning the mushroomed head of the cold chisel shown in figure 1. (2 marks)

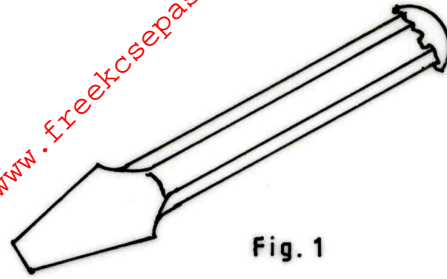
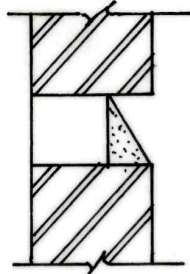
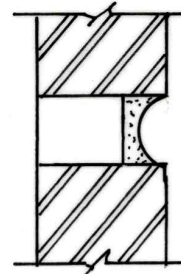

Fig. 1

- (b) Figure 2 shows masonry wall joints. Name the type of joints labelled (a) and (b) stating the advantage of each.



(a)



(b)

Fig. 2

- (i) Name: .....  
 Advantage:.....
- (ii) Name: .....  
 Advantage:.....
- (2 marks)

- 10 Figure 3 shows single line pictorial view of a dwelling house.

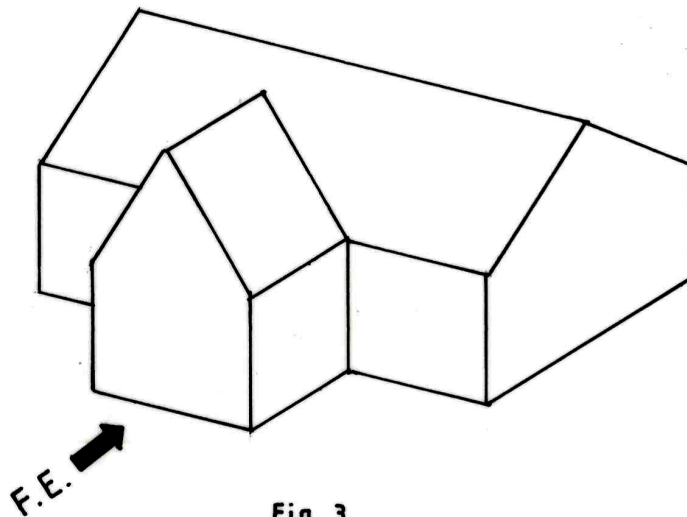

Fig. 3

- Sketch in 1st angle projection the **three** orthographic views of the house. (4 marks)

SECTION B (60 marks)

Answer **question 11** on the A3 paper provided and any other **three** questions from this section in the space provided.

Candidates are advised to spend not more than 25 minutes on question 11.

- 11 **Figure 4** shows a pictorial drawing of a shaped block. (15 marks)

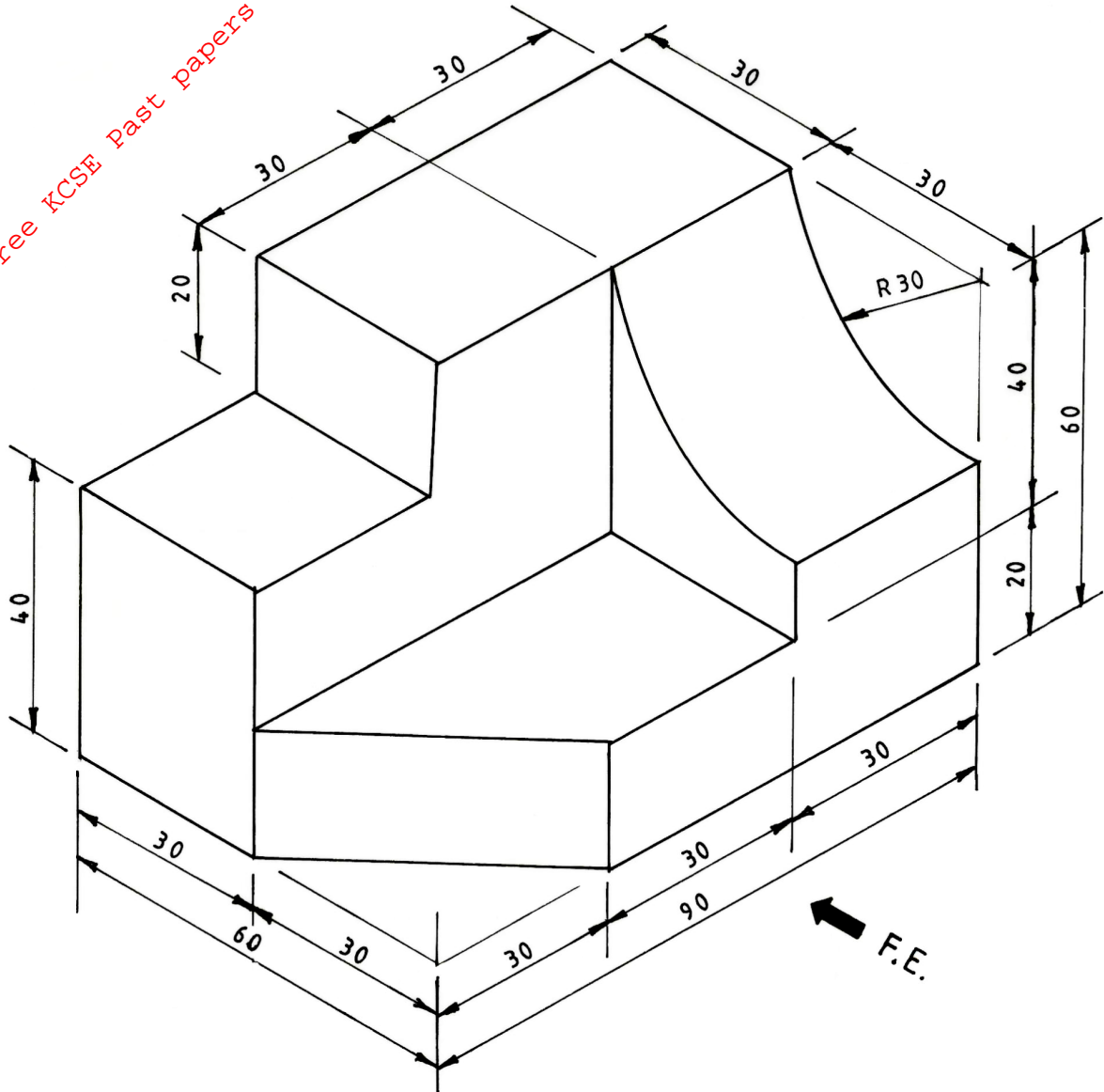

Fig. 4

To a scale of 1:1, draw **three** orthographic views of the block in 3<sup>rd</sup> angle projection. Insert **six** dimensions. (15 marks)

- 12 (a) State **five** functional requirements of masonry walls in a building. (5 marks)
- (b) **Figure 5** shows a floor plan of a house.

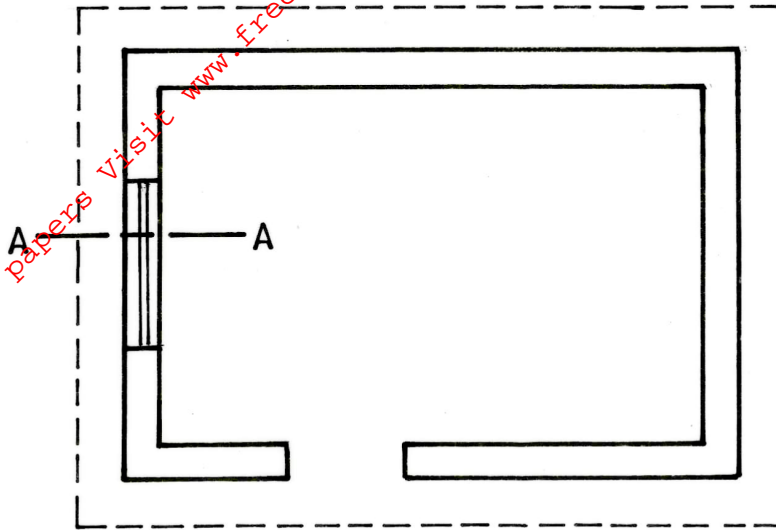

Fig. 5

Sketch and label a vertical section through A - A to show details from the foundation to the roof. (10 marks)

- 13 (a) (i) Give **one** advantage of twisted reinforcement bars over the round reinforcement bars when used in concrete.
- (ii) State the meaning of each of the items labelled A - F in the reinforcement code given:

8	Y	20	- 01 -	300 -	B
↑	↑	↑	↑	↑	↑
A	B	C	D	E	F

(7 marks)

- (b) Explain the function of each of the following in relation to plumbing works:
- (i) cold water cistern;
  - (ii) water cylinder;
  - (iii) boiler;
  - (iv) rising main.

(8 marks)

- 14 (a) Use labelled sketches to show the difference between a couple roof and a collar roof. (8 marks)
- (b) **Figure 6** shows the plan of a block wall with a pier.

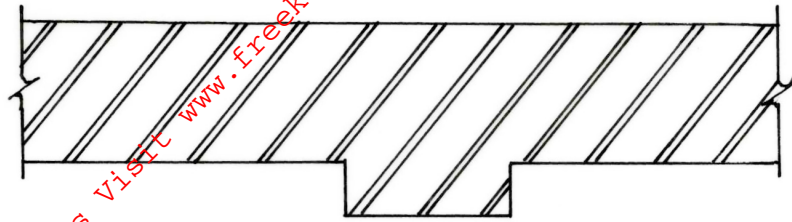

Fig 6

Sketch and label a pictorial strip foundation that will carry the wall and show the projection as per the building regulations. (7 marks)

- 15 (a) State **two** functions of each of the following:

- (i) blinding layer;
- (ii) hardcore.

(4 marks)

- (b) Sketch and label a cross-section of a trench not more than 1,000 metre deep to show timber supports in hard soils. (5 marks)

- (c) **Figure 7** shows a timber stud wall with a door opening.

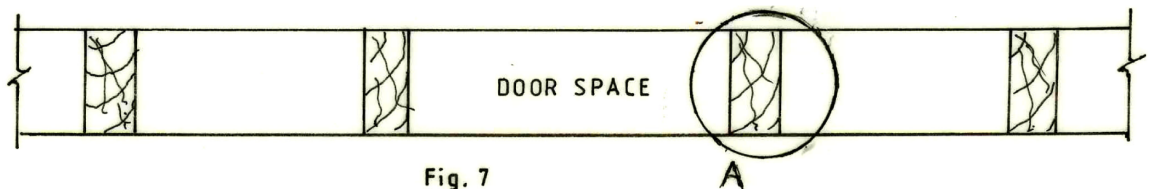

Fig. 7

Sketch the details at 'A' to show all the members at the opening. (6 marks)