

### 3.6.2 Chemistry Paper 2 (233/2)

- 1 (a) The set-up below was used to prepare dry hydrogen chloride gas, and investigate its effect on heated iron filings.

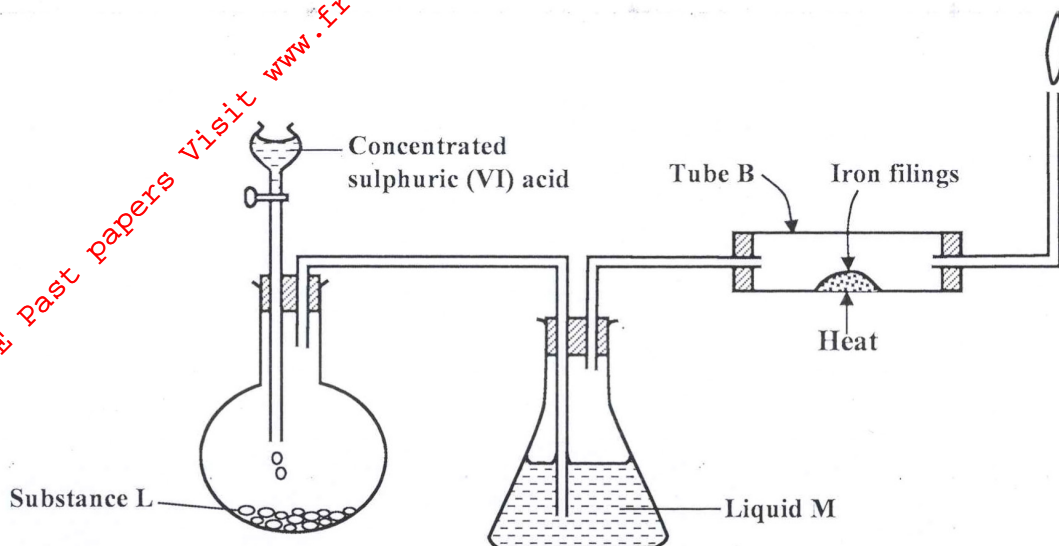

- (i) Name substance **L** (1 mark)
- (ii) Name liquid **M**. (1 mark)
- (iii) What will be observed in tube **B**? (1 mark)
- (iv) Write an equation for the reaction that occurs in tube **B**. (1 mark)
- (v) Why is the gas from tube **B** burnt? (1 mark)
- (b) (i) Explain the following observations:
- (I) a white precipitate is formed when hydrogen chloride gas is passed through aqueous silver nitrate. (1 mark)
- (II) hydrogen chloride gas fumes in ammonia gas. (1 mark)
- (ii) State **two** uses of hydrogen chloride gas. (1 mark)

- (c) The diagram below is a representation of an industrial process for the manufacture of a bleaching powder.

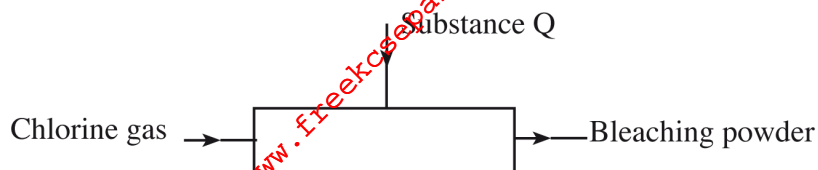

- (i) Name substance Q. (1 mark)
- (ii) When the bleaching powder is added to water during washing, a lot of soap is used. Explain. (1 mark)

- 2 (a) The grid below represents part of the periodic table. Study it and answer the questions that follow. The letters are not the actual symbols of the elements.

A				B		C		
	D			E		F	G	
H								

- (i) Select the most reactive metal. Explain. (2 marks)
- (ii) Select an element that can form an ion with a charge of  $3^-$ . (1 mark)
- (iii) Select an alkaline earth metal. (1 mark)
- (iv) Which group 1 element has the highest first ionization energy? Explain. (2 marks)
- (v) Element A combines with chlorine to form a chloride of A. State the most likely pH value of a solution of a chloride of A. Explain. (2 marks)
- (b) (i) Explain why molten calcium chloride and magnesium chloride conduct electricity while carbon tetrachloride and silicon tetrachloride do not. (2 marks)
- (ii) Under the same conditions, gaseous neon was found to diffuse faster than gaseous fluorine. Explain this observation. ( $F = 19.0$ ;  $Ne = 20.0$ ) (2 marks)

- 3 (a) Draw the structures of the following:

- (i) Butan-1-ol (1 mark)
- (ii) Hexanoic acid. (1 mark)

(b) Study the flow chart below and answer the questions that follow.

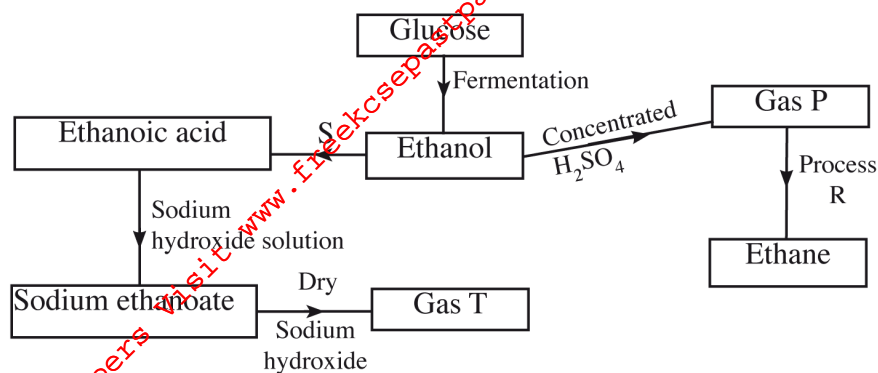

- (i) State the conditions necessary for fermentation of glucose to take place. (1 mark)
- (ii) State **one** reagent that can be used to carry out process S. (1 mark)
- (iii) Identify gases: (2 marks)
- P:.....
- T:.....
- (iv) How is sodium hydroxide kept dry during the reaction? (1 mark)
- (v) Give **one** commercial use of process R. (1 mark)
- (c) When one mole of ethanol is completely burnt in air, 1370kJ of heat energy is released. Given that 1 litre of ethanol is 780g, calculate the amount of heat energy released when 1 litre of ethanol is completely burnt. (3 marks)
- (C = 12.0; H= 1.0; O = 16.0)
- (d) State **two** uses of ethanol other than as an alcoholic drink. (2 marks)
- 4 (a) Other than temperature, state **two** factors that determine the rate of a chemical reaction. (1 mark)

- (b) A solution of hydrogen peroxide was allowed to decompose and the oxygen gas given off collected. After 5 minutes, substance G was added to the solution of hydrogen peroxide. The total volume of oxygen evolved was plotted against time as shown in the graph below.

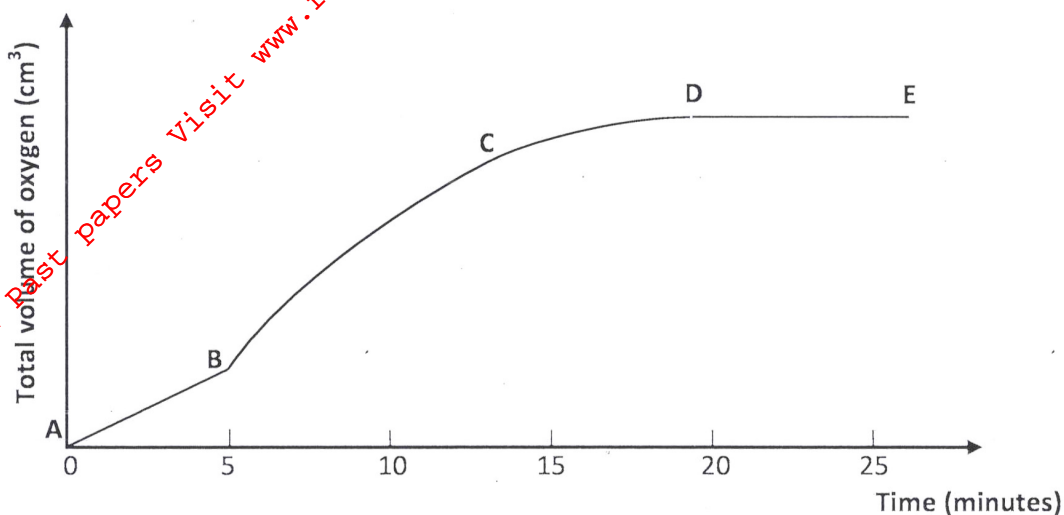

- (i) Describe the procedure of determining the rate of the reaction at minute 12. (3 marks)
- (ii) How does the production of oxygen in region AB compare with that in region BC? Explain. (2 marks)
- (iii) Write an equation to show the decomposition of hydrogen peroxide. (1 mark)
- (c) Sulphur (IV) oxide reacts with oxygen to form Sulphur (VI) oxide as shown in the equation below:



- (i) Explain the effect on the yield of  $\text{SO}_3$  of lowering the temperature for this reaction. (2 marks)
- (ii) Name **one** catalyst used for the reaction. (1 mark)

- 5 (a) The scheme below shows some of the reactions of solution **D**. Study it and answer the questions that follow.

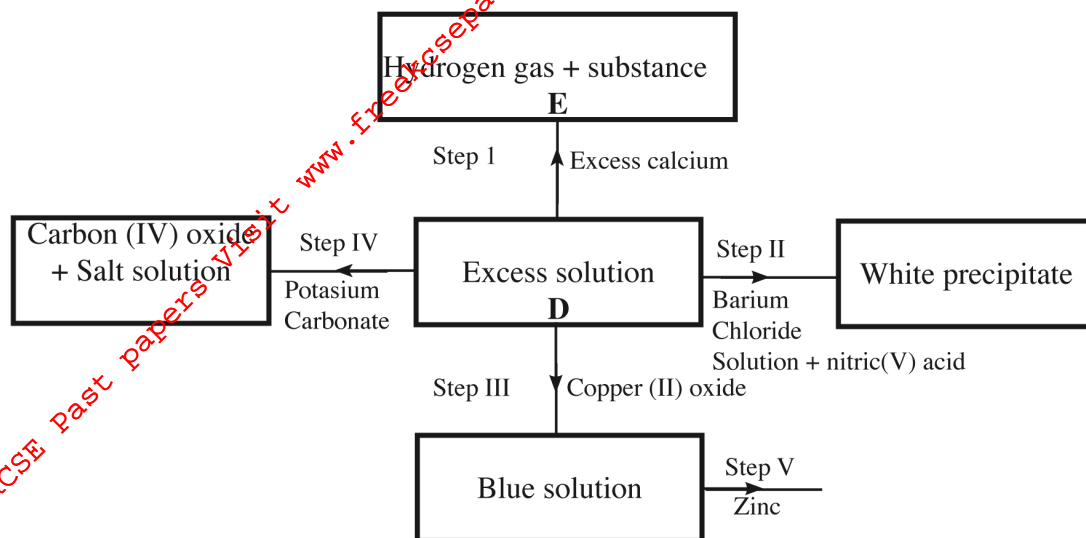

- (i) Give a possible cation present in solution **D**. (1 mark)
- (ii) Write an ionic equation for the reaction in Step II. (1 mark)
- (iii) What observations would be made in Step V? Give a reason. (2 marks)
- (iv) Explain why the total volume of hydrogen gas produced in step 1 was found to be very low although calcium and solution **D** were in excess. (2 marks)
- (v) State **one** use of substance **E**. (1 mark)
- (b) Starting with solid sodium chloride, describe how a pure sample of lead (II) chloride can be prepared in the laboratory. (3 marks)
- (c) (i) State a property of anhydrous calcium chloride which makes it suitable for use as a drying agent for chlorine gas. (1 mark)
- (ii) Name another substance that can be used to dry chlorine gas. (1 mark)

- 6 The diagram below represents a set up of an electrolytic cell that can be used in the production of aluminium.

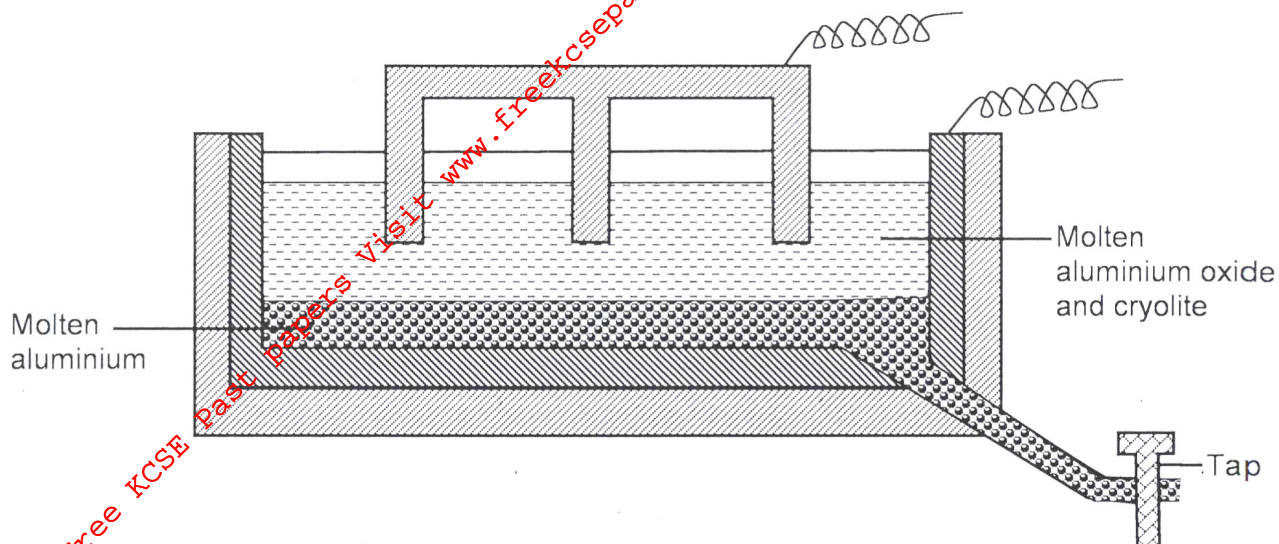

- (a) On the diagram, label the anode. (1 mark)
- (b) Write the equation for the reaction at the anode. (1 mark)
- (c) Give a reason why the electrolytic process is not carried out below  $950^{\circ}\text{C}$ . (1 mark)
- (d) Give a reason why the production of aluminium is not carried out using reduction process. (1 mark)
- (e) Give **two** reasons why only the aluminium ions are discharged. (2 marks)
- (f) State **two** properties of duralumin that makes it suitable for use in aircraft industry. (2 marks)
- (g) Name **two** environmental effects caused by extraction of aluminium. (2 marks)
7. (a) Dissolving of potassium nitrate in water is an endothermic process. Explain the effect of increase in temperature on the solubility of potassium nitrate. (2 marks)

- (b) The table below shows the solubilities of potassium sulphate and potassium chlorate (V) at different temperatures.

Temperature ( $^{\circ}\text{C}$ )	0	20	40	60	80	100
Solubility of $\text{K}_2\text{SO}_4$ g/100g water	8.0	10.0	14.0	17.5	20.0	22.0
Solubility of $\text{KClO}_3$ g/100g water	3.0	5.0	15.5	24.0	38.0	53.0

- (i) Draw the solubility curves for both salts on the same axis. (Temperature on the X-axis). (3 marks)
- (ii) A solution of potassium sulphate contains 20g of the salt dissolved in 100g of water at  $100^{\circ}\text{C}$ . This solution is allowed to cool to  $25^{\circ}\text{C}$ .
- I At what temperature will crystals first appear? (1 mark)
- II What mass of crystals will be present at  $25^{\circ}\text{C}$ ? (1 mark)
- (iii) Which of the **two** salts is more soluble at  $30^{\circ}\text{C}$ ? (1 mark)
- (iv) Determine the concentration of potassium sulphate in moles per litre when the solubility of the two salts are the same ( $\text{K} = 39.0$ ,  $\text{O} = 16.0$ ;  $\text{S} = 32.0$ ). (3 marks)
- (v) 100g of water at  $100^{\circ}\text{C}$  contains 19g of potassium sulphate and 19g of potassium chlorate (V). Describe how a solid sample of potassium sulphate at  $60^{\circ}\text{C}$  can be obtained. (2 marks)

### 3.6.3 Chemistry Paper 3 (233/3)

1 You are provided with:

- solution **J** containing copper (II) ions.
- solution **K**, 0.1 M sodium thiosulphate.
- aqueous potassium iodide, solution **L**.
- solution **N**, sodium hydroxide.
- starch indicator, solution **M**.

You are required to determine the:

- concentration of copper (II) ions in solution **J**;
- enthalpy change of reaction between copper (II) ions and hydroxide ions.

#### PROCEDURE I

- (a) Using a pipette and **pipette filler**, place 25.0 cm<sup>3</sup> of solution **J** in a 250 ml volumetric flask. Add distilled water to make up to the mark. Label this as solution **J**<sub>2</sub>. Retain solution **J** for use in **procedure II**.
- (b) Place solution **K** in a burette. Using a clean pipette and **pipette filler**, place 25.0 cm<sup>3</sup> of solution **J**<sub>2</sub> in a 250 ml conical flask. Add 10 cm<sup>3</sup> of potassium iodide, solution **L**. Shake well, then add 2 cm<sup>3</sup> of starch indicator, solution **M**. Titrate until a blue-black colour appears and continue titrating until the blue-black colour just disappears. Record your readings in **Table 1** below.
- (c) Repeat step (b) two more times and complete **Table 1**.

	I	II	III
Final burette reading			
Initial burette reading			
Volume of solution <b>K</b> (cm <sup>3</sup> ) used			

**Table 1**

(3 marks)

Calculate the;

- (i) average volume of solution **K** used; (1 mark)
- (ii) moles of sodium thiosulphate used; (2 marks)
- (iii) concentration in moles per litre of copper (II) ions in solution **J** given that the number of moles of copper (II) ions in 25.0 cm<sup>3</sup> of solution **J**<sub>2</sub> are the same as the moles of sodium thiosulphate used. (2  $\frac{1}{2}$  marks)



### PROCEDURE II

- (a) Using a clean burette, place 5.0 cm<sup>3</sup> of solution **N** into each of six (6) test-tubes.
- (b) Using a 100 ml measuring cylinder, place 20 cm<sup>3</sup> of solution **J** in a 100 ml plastic beaker. Measure the temperature of solution **J** and record it in **Table 2** below.
- (c) To solution **J** in the beaker, add sodium hydroxide, solution **N** from one of the test-tubes. Stir the mixture with the thermometer and record in **Table 2**, the maximum temperature reached. Continue with step (d) **IMMEDIATELY**.
- (d) Add the sodium hydroxide, solution **N** from another test-tube to the mixture obtained in (c) above, stir and record the maximum temperature reached in **Table 2**. Continue adding the sodium hydroxide, solution **N** from each of the other four test-tubes, stirring the mixture and recording the maximum temperature each time and complete **Table 2**.

Volume of sodium hydroxide, solution <b>N</b> added (cm <sup>3</sup> )	0	5	10	15	20	25	30
Maximum temperature (°C)							

**Table 2**

(3½ marks)

- (i) On the grid provided, plot a graph of temperature (vertical axis) against volume of sodium hydroxide solution **N** added. (3 marks)



- (ii) Using the graph, determine the:

I volume of sodium hydroxide, solution **N** that reacted completely with 20 cm<sup>3</sup> of solution **J**; (2 marks)

II temperature change,  $\Delta T$ , for the reaction; (1 mark)

(iii) enthalpy change of the reaction per mole of copper (II) ions. (3 marks)  
(Heat capacity =  $4.2 \text{ J g}^{-1} \text{ K}^{-1}$ , density of the mixture =  $1.0 \text{ g cm}^{-3}$ ).

2 You are provided with substance **P**. Carry out the tests below and write your observations and inferences in the spaces provided.

(a) Describe the appearance of substance **P**. (1 mark)

.....

(b) Place about one-third of substance **P** in a dry test-tube and heat it strongly.

Observations	Inferences
(1 mark)	(1 mark)

(c) Place the remaining amount of substance **P** in a boiling tube. Add about  $10 \text{ cm}^3$  of distilled water and shake well. **Retain** the mixture for tests in (d) below.

Observations	Inferences
(1 mark)	(1 mark)

(d) Use about  $2 \text{ cm}^3$  portions of the mixture obtained in (c) for tests (i) to (iii) below.

(i) Add two to three drops of aqueous barium nitrate to the mixture.

Observations	Inferences
(1 mark)	(2 marks)

(ii) Add five drops of dilute nitric(V) acid to the mixture.

Observations	Inferences
(1 mark)	(1 mark)

(iii) Add to the mixture, aqueous sodium hydroxide dropwise until in excess.

Observations	Inferences
(1 mark)	(1 mark)

(e) Give the formula of the cation and anion present in substance **P**.

Cation: ..... ( $\frac{1}{2}$  mark)

Anion: ..... ( $\frac{1}{2}$  mark)

3 You are provided with an organic substance **Q**. Carry out the following tests and record your observations and inferences in the spaces provided.

- (a) Place about one-third of substance **Q** on a **metallic spatula** and ignite it with a Bunsen burner flame.

Observations	Inferences
(1 mark)	(1 mark)

- (b) Place the remaining amount of substance **Q** in a boiling tube and add about 10 cm<sup>3</sup> of distilled water. Heat the mixture and allow it to boil for about 30 seconds. Divide the mixture while still hot into two portions.

- (i) To the first portion, add solid sodium hydrogen carbonate provided.

Observations	Inferences
(1 mark)	(1 mark)

- (ii) To the second portion, add two or three drops of acidified potassium manganate (VII).

Observations	Inferences
(1 mark)	(1 mark)

### 3.6 CHEMISTRY (233)

#### 3.6.1 Chemistry Paper 1 (233/1)

- 1 Explain how the hotness of a Bunsen burner flame can be increased. (1 mark)
- 2 When dilute hydrochloric acid was reacted with solid B, a colourless gas which extinguished a burning splint was produced. When an aqueous solution of solid B was tested with a blue litmus paper, the paper turned red/ pink.
- (a) Identify the anion present in solid B. (1 mark)
- (b) Write an ionic equation for the reaction between solid B and dilute hydrochloric acid. (1 mark)
- 3 Dry ammonia gas was passed over heated lead (II) oxide and the products passed over anhydrous copper (II) sulphate as shown in the diagram below.

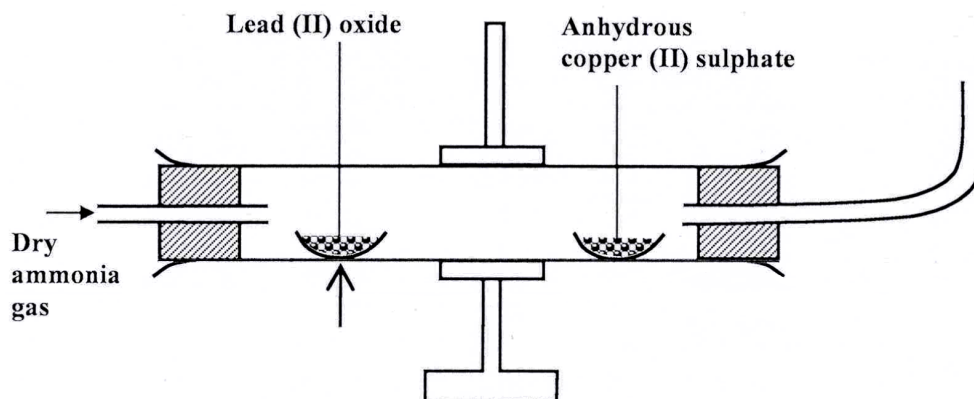

State:

- (a) **two** observations made in the combustion tube. (2 marks)
- (b) the property of ammonia gas shown in this experiment. (1 mark)
- 4 Starting with zinc sulphate solution, describe how a sample of zinc oxide can be obtained. (3 marks)
- 5 Explain how conduction of electricity takes place in the following:
- (a) iron metal; (1 mark)
- (b) molten lead (II) iodide. (1 mark)

- 6 100 cm<sup>3</sup> of a sample of ethane gas diffuses through a porous pot in 100 seconds. What is the molecular mass of gas Q if 100 cm<sup>3</sup> of the gas diffuses through the same porous pot in 121 seconds under the same conditions?  
(C = 12.0, H = 1.0) (3 marks)

- 7 (a) Draw and name the isomers of butyne. (2 marks)  
(b) State **one** use of polystyrene. (1 mark)

8 Complete the nuclear reaction below:



- (b) State **two** uses of radioisotopes in health. (2 marks)

- 9 The table below shows the relative molecular masses and boiling points of pentane and ethanoic acid.

	Relative molecular mass	Boiling point (°C)
Pentane	72	36
Ethanoic acid	60	118

Explain the large difference in boiling point between ethanoic acid and pentane. (2 marks)

- 10 One of the ores of copper has the formula, CuFeS<sub>2</sub>.

- (a) Describe how iron in the ore is removed during extraction of copper metal. (1 mark)  
(b) State **two** environmental problems associated with extraction of copper metal. (2 marks)

11 Study the flow chart below and answer the questions that follow.

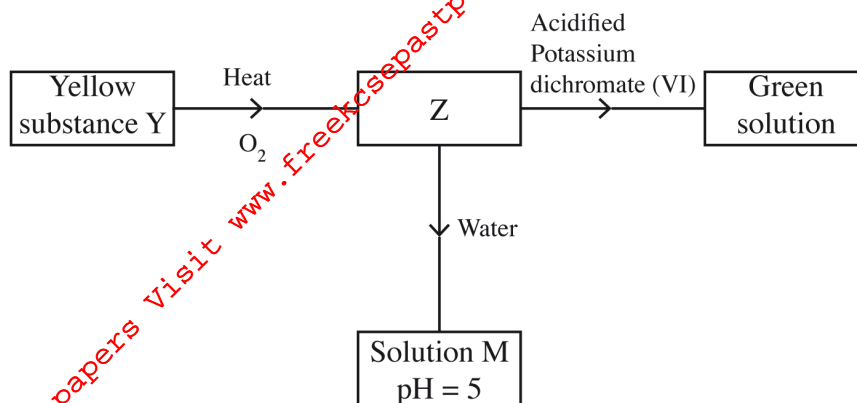

Identify Z and M.

(2 marks)

Z .....

M .....

12 The table below shows the pH values of solutions A, B, C and D.

Solution	A	B	C	D
pH	2	7	11	14

Select solutions in which a sample of lead (II) hydroxide is likely to dissolve. Give reasons for each solution selected. (3 marks)

13 100 cm<sup>3</sup> of 0.05 M sulphuric (VI) acid were placed in a flask and a small quantity of anhydrous sodium carbonate added. The mixture was boiled to expel all the carbon (IV) oxide. 25 cm<sup>3</sup> of the resulting solution required 18 cm<sup>3</sup> of 0.1 M sodium hydroxide solution to neutralise it. Calculate the mass of sodium carbonate added. (Na = 23.0; O = 16.0; C = 12.0) (3 marks)

14 When 20 cm<sup>3</sup> of 1 M sodium hydroxide was mixed with 20 cm<sup>3</sup> of 1 M hydrochloric acid, the temperature rose by 6.7 °C. Assuming the density of the solution is 1 g/cm<sup>3</sup> and the specific heat capacity of the solution is 4.2 Jg<sup>-1</sup> K<sup>-1</sup>;

(a) calculate the molar heat of neutralisation; (2 marks)

(b) when the experiment was repeated with 1 M ethanoic acid, the temperature change was found to be lower than that with 1 M hydrochloric acid. Explain. (1 mark)

15 Study the set-up below and answer the questions that follow.

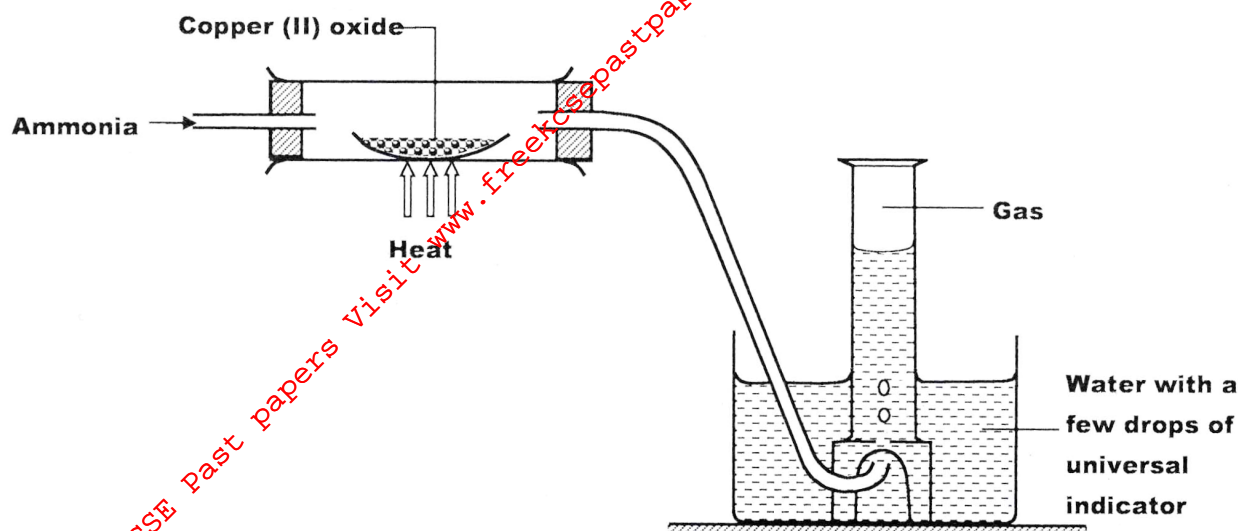

- (a) Write an equation for the reaction between ammonia and copper (II) oxide. (1 mark)
- (b) During the experiment, the colour of the contents in the water trough changed. State the colour change observed and give an explanation. (2 marks)

16 A measuring cylinder fitted with moist steel wool was inverted in a trough of water as shown in the diagram below.

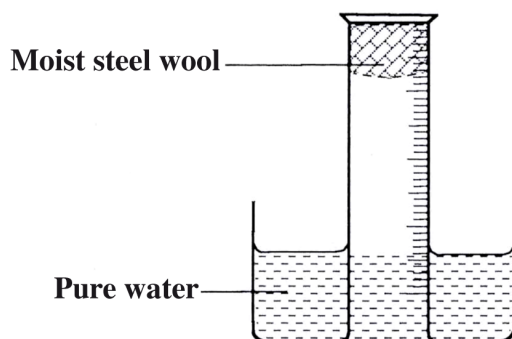

- (a) State and explain the observations made on the:
- (i) moist steel wool after four days. (1 mark)
- (ii) water level in the measuring cylinder after four days. (1 mark)
- (b) What would be the effect of using steel wool moistened with salty water? (1 mark)

17 In an experiment on rates of reaction, potassium carbonate was reacted with dilute sulphuric (VI) acid.

- (a) What would be the effect of an increase in the concentration of the acid on the rate of the reaction? (1 mark)



(b) Explain why the rate of reaction is found to increase with temperature. (2 marks)

18 Use the part of the periodic table given below to answer the questions that follow. (Letters are not the actual symbols of the elements).

			N		P	
Q	M					R

(a) Identify the element that forms giant covalent structures. (1 mark)

(b) Identify **one** element that does not form compounds. (1 mark)

(c) Write the formula for the nitride of M. (1 mark)

19 Draw a set up that can be used to separate a mixture of sand and iodine. (3 marks)

20 In the contact process, during the production of sulphur (VI) oxide, a catalyst is used. Give **two** reasons why vanadium (V) oxide is preferred to platinum. (2 marks)

21 Given that the atomic number of Y is 13 and that of Z is 9:

(a) write the electronic arrangement of Y and Z; (1 mark)

(b) draw the dot (•) and cross (x) diagram for the compound formed by Y and Z. (1 mark)

- 22 The set up below was used to separate a mixture of methanol and propanol. Study it and answer the questions that follow.

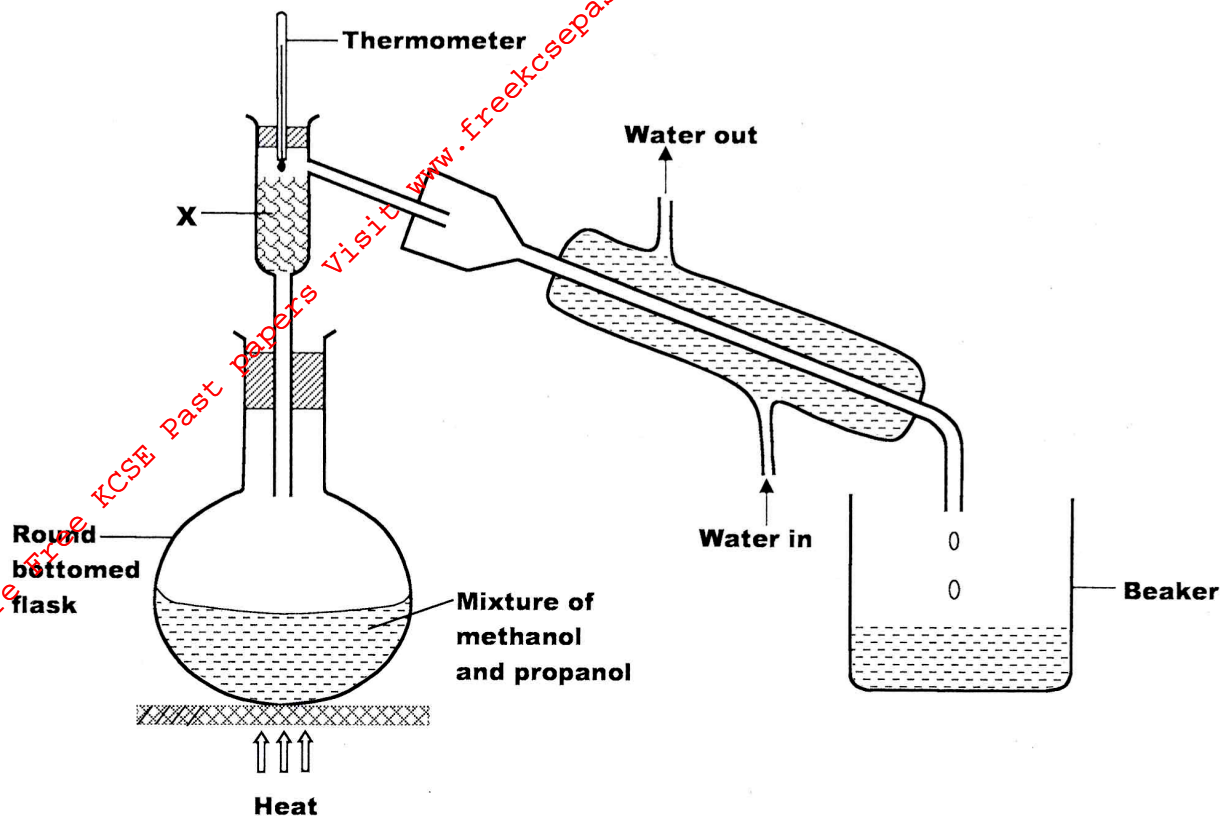

- (a) State the function of X. (1 mark)
- (b) Which liquid will collect first in the beaker? Give a reason. (2 marks)

- 23 Study the flow chart below and answer the questions that follow.

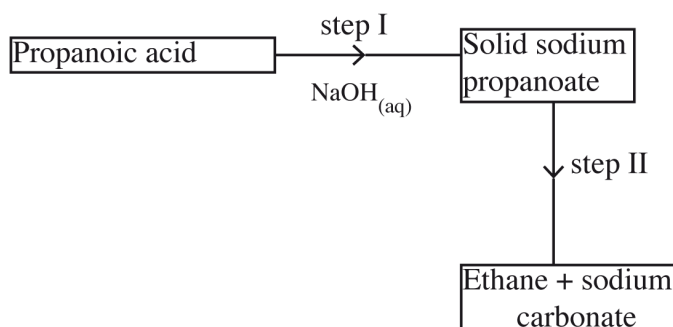

- (a) Name the process in step I. (1 mark)
- (b) Identify the reagent in step II. (1 mark)
- (c) Give **one** use of ethane. (1 mark)

- 24 (a) A student electrolysed dilute sodium chloride solution using inert carbon electrodes. Name the products at:
- (i) anode;
- (ii) cathode.
- (2 marks)
- (b) If the experiment was repeated using concentrated sodium chloride instead of dilute sodium chloride solution, write the half equation at the anode.
- (1 mark)

25 An organic compound had the following composition 37.21% carbon, 7.75% hydrogen and the rest chlorine. Determine the molecular formula of the compound, given that the molecular mass of the compound is 65. (C = 12.0; H = 1.0; Cl = 35.5). (3 marks)

26 Cotton is a natural polymer. State **one** advantage and **one** disadvantage of this polymer. (2 marks)

Advantage: .....

Disadvantage: .....

- 27 (a) Name a suitable solvent for extracting an indicator from flowers; (1 mark)
- (b) Give a reason why the solvent named in (a) above is used. (1 mark)

28 A student used the set up below to prepare a sample of nitrogen gas.

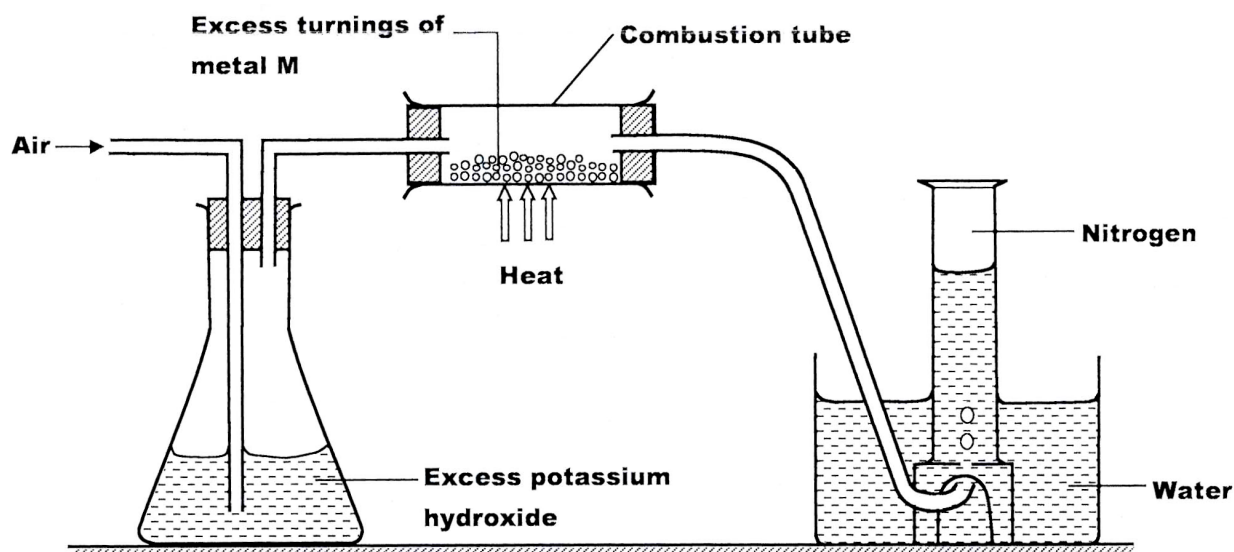

- (a) State the function of potassium hydroxide in the set up. (1 mark)
- (b) Give a suitable metal M for use in the combustion tube. (1 mark)

(c) Give a reason why the nitrogen gas obtained is not pure. (1 mark)

29 (a) What is meant by the term radical? (1 mark)

(b) The table below contains atoms that form common radicals. Complete the table to show radicals formed from various atoms.

Element	N	S
H	$\text{NH}_4^+$	
O		

(2 marks)

30 A gas jar full of chlorine water was inverted over water and allowed to stand for sometime.

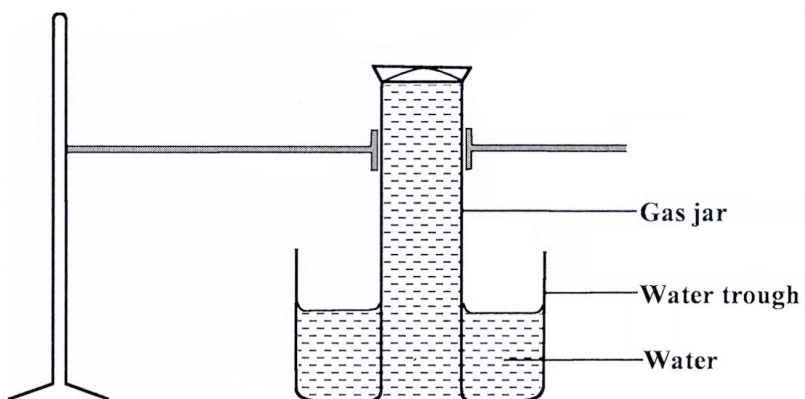

(a) State and explain **two** observations made in the gas jar after some time. (2 marks)

(b) Write the equation for the reaction between chlorine and hot concentrated potassium hydroxide. (1 mark)