

NAME.....AdmNo.....

Class.....

Candidate Sign..... Date.....

233/1

CHEMISTRY

(THEORY)

PAPER1

TIME: 2HOURS

Instructions:

- Write your name, admission number, and class in the spaces provided above
- Sign, write date and time of examination in the spaces provided above
- Answer all questions in the spaces provided
- All working must be clearly shown where necessary
- Electronic calculators may be used for calculations

For Examiner's Use only

Questions	MAXIMUM Score	Candidate's score
1-28	80	

This paper consist of 10 printed pages. Students should check the question paper to ensure That all pages are printed as indicated and that no questions are missing.

1. Name and state the use of the apparatus represented below. (2marks)

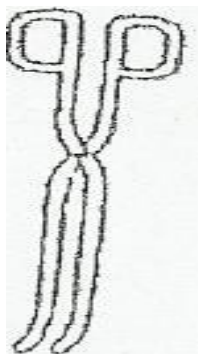

2. Give the systematic name of each of the compounds represented by the formulae below (3marks)

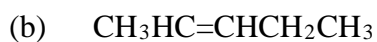

3. A fixed mass of gas occupies 105cm^3 at -140°C AND 650mm Hg . At what temperature will it have a volume of 15cm^3 if pressure is adjusted to 690 ? (3marks)

4a) Using dots (·) and crosses (x) to represent electrons, show the bonding in the compounds formed between magnesium and fluorine. (Atomic numbering; Mg=12, F=9) (1mark)

b) State one likely physical property of the compound formed between magnesium and fluorine in (a) above. (1mark)

5. A set-up to investigate electrical conductivity of substances was assembled as shown below the bulb did not light.

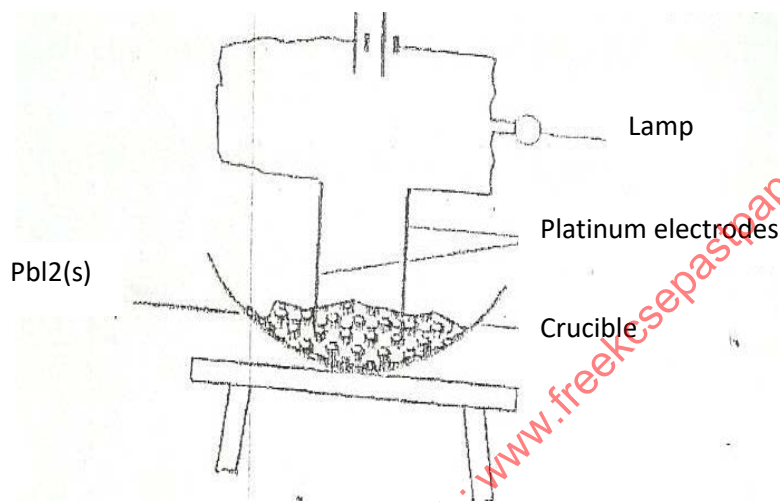

(a) What was missing in the set-up? (1mark)

6 The bulb lit when the omission was corrected. Explain. (2marks)

7 An oxide of copper in a porcelain boat was reduced by a stream of hydrogen. The results obtained were as follows;

Mass of porcelain boat = 4.5g

Mass of boat + Oxide = 6.40g

Mass of boat + copper = 6.02g

i) Define the empirical formula of the oxide (3marks)

ii) If the relative formula of the oxide is 80, determine its chemical formula.

(Cu =64, O=16)

(1mark)

7. Starting with copper metal, describe how to prepare solid copper (II) Carbonate. (3marks)

8. The ammeter readings below were obtained using separate equal volumes of 2M aqueous solution of ethanoic acid and hydrochloric acid. Study the information and answer the questions that follow

	Ammeter Reading (A)
Ethanoic acid	0.3
Hydrochloric acid	1.0

Explain the difference in the ammeter readings for the two acids.

(3marks)

9. A study set up the following experiment to study the effect of heat on lead (II) nitrate.

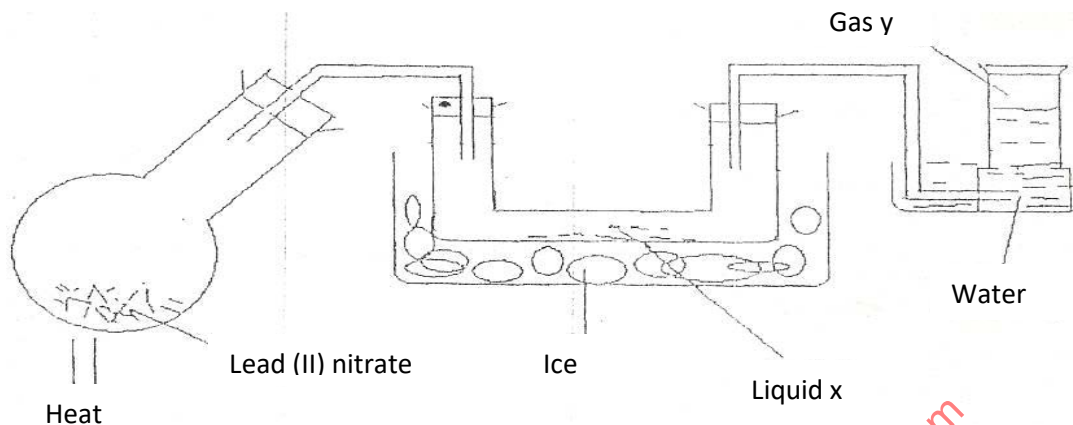

- i) Identify liquid X (1mark)
- ii) Describe the test for gas Y (2marks)
- iii) Write a balanced chemical equation for the reaction taking place in the flask (1mark)

10. The set-up represented below can be used to separate ethanol from its mixture with water.

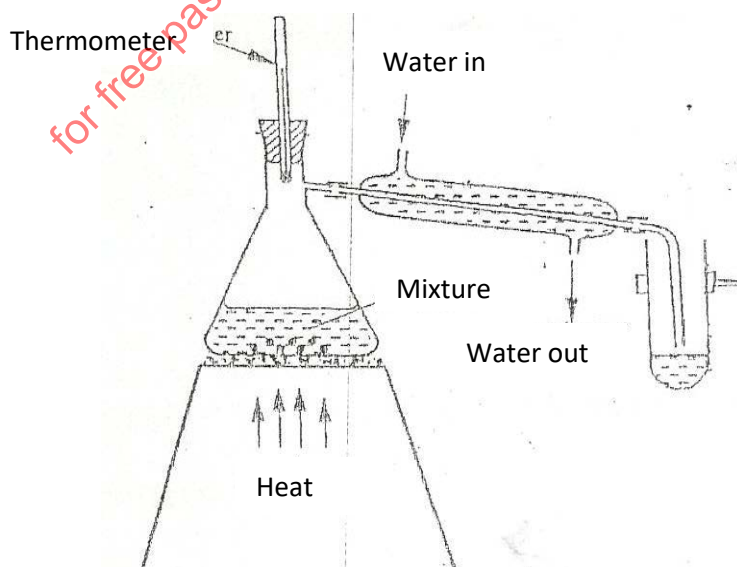

- a) Identify an error in the set-up (1mark)
- b) Name this method of separation (1mark)
- (c) What properties make it possible to separate ethanol from water by this method? (1mark)

11. Describe how to distinguish between substance I and II below using sodium carbonate



(3marks)

12. Element K has two isotopes ^{20}K and ^{22}K with relative abundance of 90% and 10% relatively.

- a) What are isotopes? (1mark)
- b) Determine the relative atomic mass of element K (2marks)

13. Give one application of calcium oxide (1mark)

14. (a) State Hess' law (1mark)

(b) The diagram below shows an energy cycle.

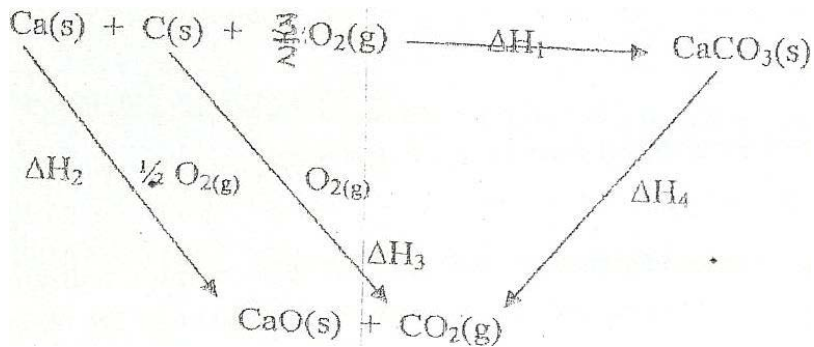

Given: $\Delta H_1 = -1207 \text{ kJ/mol}$, $\Delta H_2 = -635 \text{ kJ/mol}$, $\Delta H_3 = -394 \text{ kJ/mol}$

Determine the value of ΔH_4

15. State one use of:

a) Calcium nitrate (1mark)

b) Magnesium hydroxide (1mark)

16. Draw a labeled diagram to show how an iron spoon can be electroplated with copper. (3marks)

17. Sulphur burns in air to form a gaseous product

i) What is the colour of the flame of burning sulphur? (1mark)

ii) Give an equation for the reaction that takes place when the gaseous product is bubbled through water. (1mark)

iii) State one importance of the product formed in 17 (ii) above. (1mark)

18. Water from a river is pumped through a column filled with complex sodium compounds in order to soften it. The water is then tapped for domestic use as shown in the diagram below.

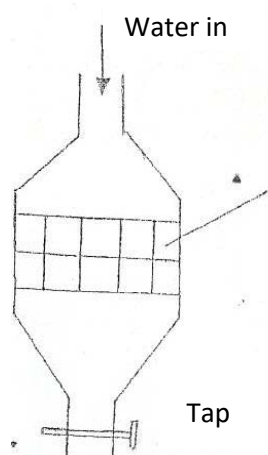

a) Explain how hard water was softened as it passed through the column. (1mark)

b) Explain how the column is regenerated after it has lost its ability to soften hard water. (1mark)

c) Give two disadvantages of hard water. (1mark)

19. Four metals are labeled P, Q, R and S (not actual symbols). Metal P displaces metal S from its oxide but cannot displace R from its oxide. Q when mixed with the oxide of R and heated, a reaction occurs. Arrange the metal in order of reactivity, starting with the most reactive. (2marks)

20. The following results were obtained in an experiment to determine the solubility of a salt at 25°C.

Mass of evaporating dish = 21.2g

Mass of evaporating dish + saturated solution = 37.4g

Mass of evaporating dish + dry solid salt = 25.4g

Calculate the solubility of the salt at 25°C. (3marks)

21. The table below shows the first ionization energies of elements P and Q.

Element	1 st Ionization energy kJ/mole
P	494
Q	418

a) What do these values suggest about reactivity of P compared to that of Q? Explain. (2marks)

b) State two factors that influence ionization energy (1mark)

22. Steam is passed over heated iron filings in a combustion tube.

a) Name the products of this reaction. (2marks)

b) Write an equation for the reaction that occurs (1mark)

23. Ethane reacts with chlorine as shown below.

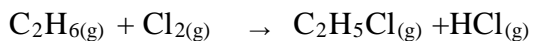

(a) Give the name of this type of reaction (1mark)

(b) Identify the overall bonds that are broken and those that are formed. (2marks)

Bonds broken

Bonds Formed

24. 30cm³ of 0.5M hydrochloric acid was used to neutralize 25cm³ of sodium hydroxide solution. Determine the concentration of sodium hydroxide in grams per litre. (3marks)

25. Describe how a detergent functions in cleaning. (3marks)

26.a) Write balanced chemical equations for reactions between chlorine and; (2marks)

i) Concentrated sodium hydroxide

ii) Dilute sodium hydroxide

- b) State one observation made when a gas jar of moist hydrogen sulphide is inverted over a gas jar of dry chlorine gas. (1mark)

27. a) Hydrogen sulphide gas is bubbled through bromine water.

i) Give two observations made (2marks)

ii) Write two observations made during this experiment. (1mark)

b) State the test for hydrogen sulphide gas. (1mark)

28. (a) State Gay-Lussac's law (2mark)

(b) When 100cm^3 of gaseous hydrocarbon (C_xH_y) burns in 300cm^3 of oxygen, 200cm^3 of carbon (IV) oxide and 200cm^3 of steam are formed. Deduce the formula of the hydrocarbon. (2marks)