

THE KENYA NATIONAL EXAMINATIONS COUNCIL
Kenya Certificate of Secondary Education

232/2

— PHYSICS —

Paper 2



Nov. 2019 – 2 hours



Name Index Number

Candidate's Signature Date

Instructions to candidates

- (a) Write your name and index number in the spaces provided above.
- (b) Sign and write the date of examination in the spaces provided above.
- (c) This paper consists of **two** sections; **A** and **B**.
- (d) Answer **all** the questions in sections **A** and **B** in the spaces provided.
- (e) All working **must** be clearly shown in the spaces provided in this booklet.
- (f) Non programmable silent electronic calculators may be used.
- (g) **This paper consists of 16 printed pages.**
- (h) **Candidates should check the question paper to ascertain that all the pages are printed as indicated and that no questions are missing.**
- (i) **Candidates should answer the questions in English.**

For Examiner's Use Only

Section	Question	Maximum Score	Candidate's Score
A	1-14	25	
	15	11	
B	16	12	
	17	11	
	18	10	
	19	11	
Total Score		80	



919360



Turn over

SECTION A (25 marks)

Answer *all* the questions in this section in the spaces provided.

1. **Figure 1** shows two plane mirrors inclined at an angle of 120° to each other. A ray of light makes an angle of 40° with the first mirror.

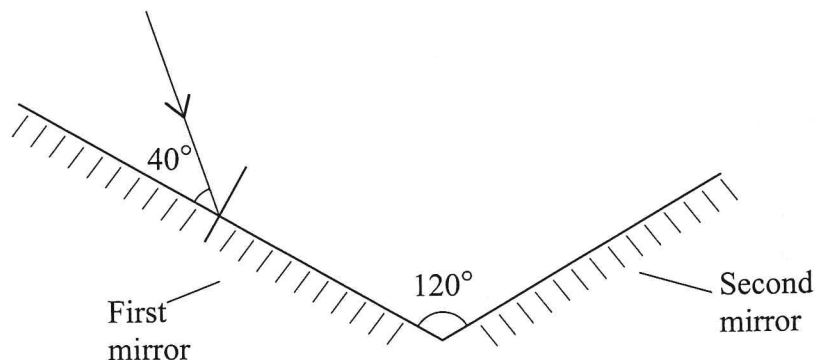

Figure 1

By completing the ray diagram determine the angle of reflection on the second mirror.

(2 marks)

2. State the reason why an increase in leaf divergence is the only sure way of determining whether an object is negatively charged using a negatively charged electroscope. (1 mark)

.....

.....

.....

3. State **two** properties of magnetic field lines around a bar magnet. (2 marks)

.....

.....

.....

.....

4. **Figure 2** shows an incomplete circuit for an electromagnet.

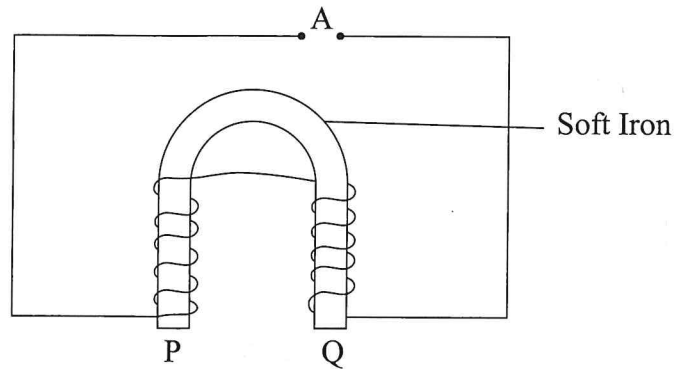

Figure 2

- (a) Complete the diagram to show how a battery should be connected at **A** so that the polarities at P and Q are South and North respectively. (1 mark)
- (b) State **two** ways in which the strength of the electromagnet in (a) can be increased. (2 marks)

.....

.....

.....

.....

5. In a siren, sound is produced when a jet of air is directed perpendicular to a ring of holes on a rotating wheel. Explain the effect on the pitch of sound produced when the speed of rotation of the wheel is increased. (2 marks)

.....

.....

.....

.....

6. State the reason why the current produced by a simple cell falls rapidly when the cell is being used. (1 mark)

.....

.....

7. **Figure 3** shows a cell connected in series with an ammeter, a $2\ \Omega$ resistor and a switch. A voltmeter is connected across the cell.

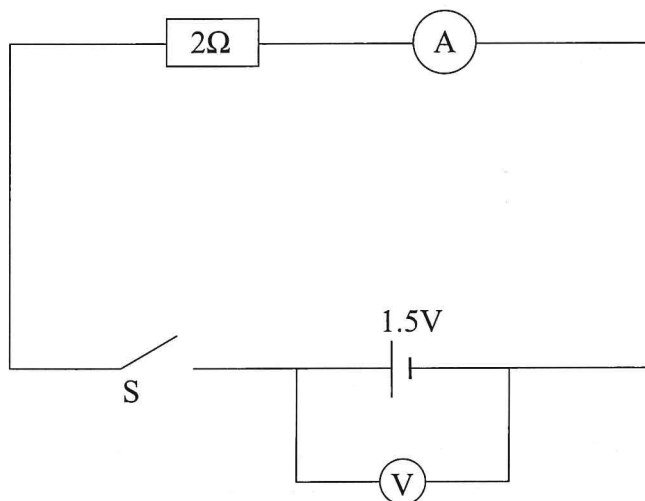

Figure 3

With the switch open, the voltmeter reads 1.5 V. Given that the internal resistance of the cell is $0.5\ \Omega$, determine the ammeter reading when the switch is closed. (3 marks)

.....

.....

.....

.....

8. State **two** uses of gamma rays in medicine. (2 marks)

.....

.....

.....



9. **Figure 4** shows the input and output signals on a CRO screen when two diodes are used during a full wave rectification.

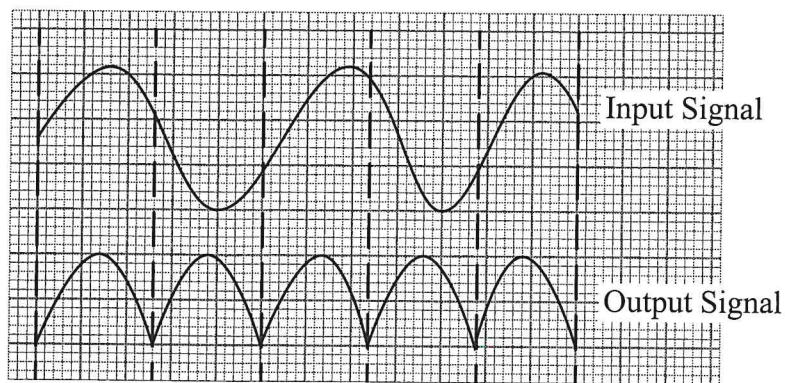

Figure 4

922

Explain how the two diodes rectify the input signal.

(3 marks)

.....

.....

.....

.....

10. State how the intensity of X-rays in an X-ray tube can be increased.

(1 mark)

.....

.....

.....

.....

0096



11. **Figure 5** shows part of the lighting circuit in a house.

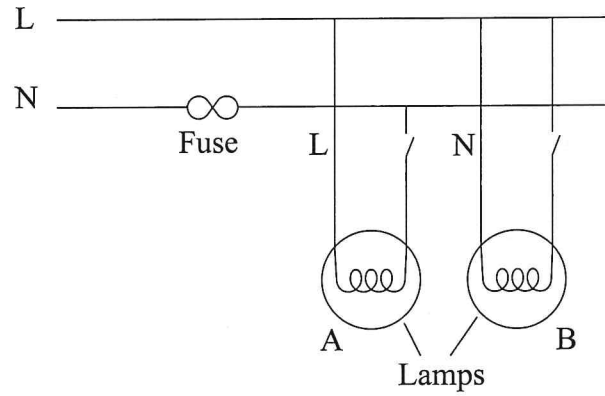

Figure 5

State **two** errors in the wiring circuit.

(2 marks)

.....

.....

.....

.....

12. Uranium decays as shown below.

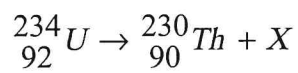

Name the particle X that is emitted during this decay.

(1 mark)

.....

13. State the disadvantage of using a convex mirror as a driving mirror. (1 mark)

.....
.....

14. Figure 6 shows radiation from the sun passing through glass in a greenhouse onto the floor. The floor then emits radiation.

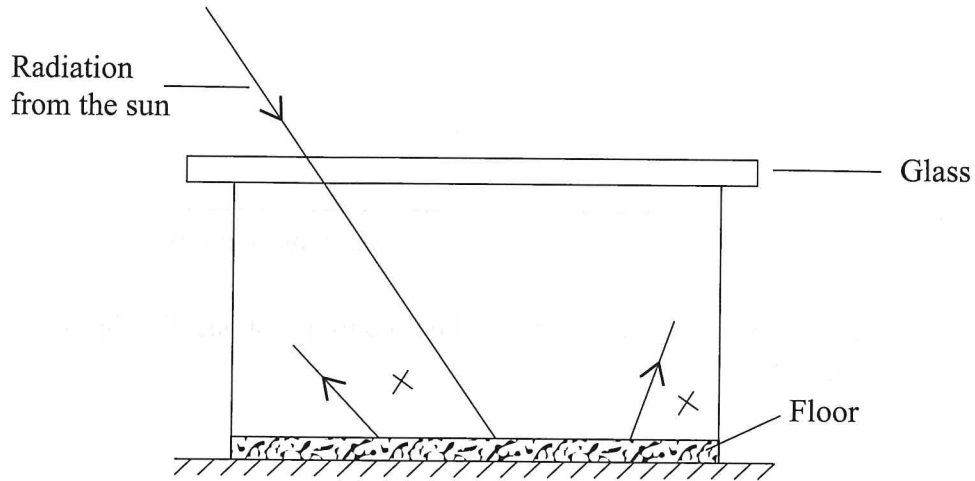

Figure 6

State the name of the radiation emitted by the floor. (1 mark)

.....
.....
.....

SECTION B (55 marks)

Answer *all* the questions in this section in the spaces provided.

15. (a) On the axes provided, sketch a graph of capacitance against the area of overlap of the plates of a parallel-plate capacitor. (1 mark)

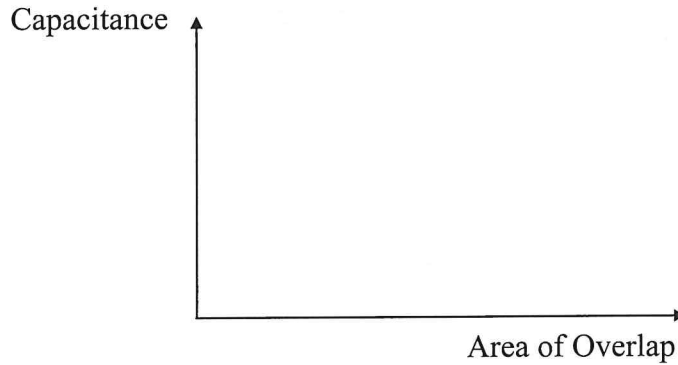

- (b) (i) Draw a circuit diagram that may be used to investigate the discharging process of a capacitor. (2 marks)

- (ii) On the axes provided sketch the graph of potential difference between the plates against time for the discharging process. (1 mark)

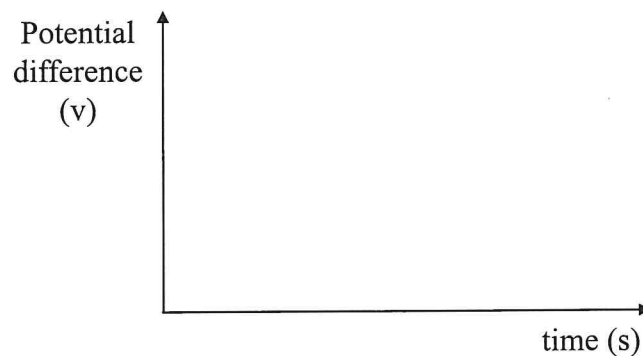

(c) Figure 7 shows three capacitors connected to a 6V battery.

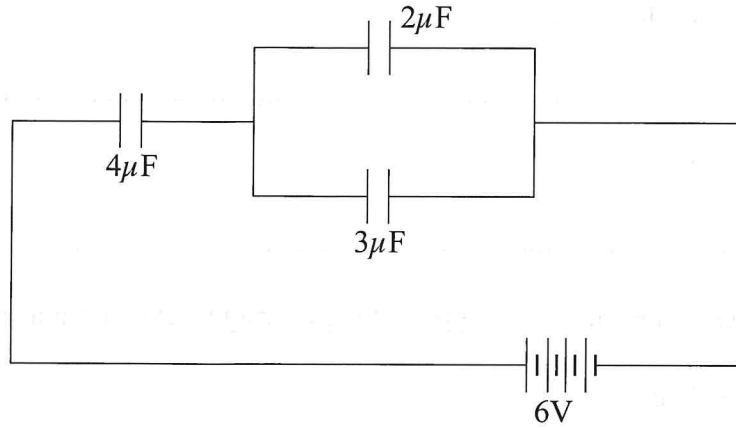

Figure 7

Determine the:

(i) effective capacitance (3 marks)

.....

.....

.....

(ii) total charge stored (2 marks)

.....

.....

.....

(iii) potential difference across the $4\mu\text{F}$ capacitor (2 marks)

.....

.....

.....



16. (a) Define the following terms as used in waves:

(i) Amplitude (1 mark)

.....

(ii) Wavelength (1 mark)

.....

(b) **Figure 8** shows water waves approaching a straight reflector at a speed of 40 cm s^{-1} .

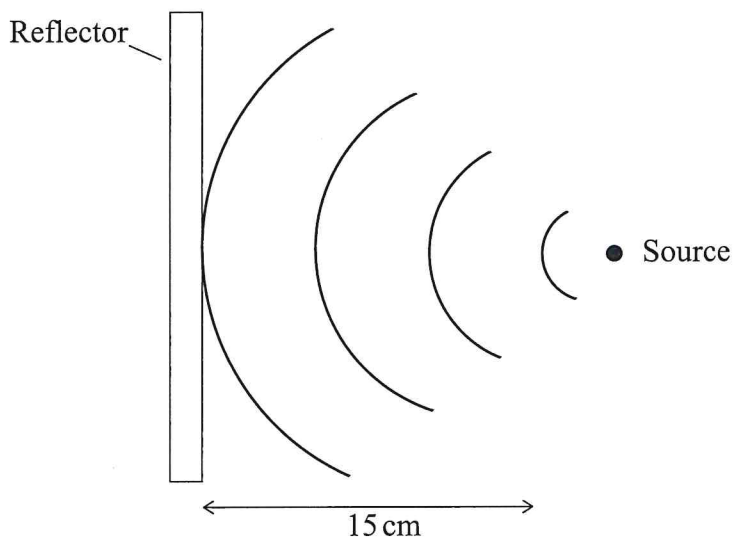

Figure 8

(i) Draw on the diagram the reflected waves. (3 marks)

(ii) Given that the distance between the source and the reflector is 15 cm determine:

I. the wavelength of the waves (2 marks)

.....

II. the frequency of the waves (2 marks)

.....

Figure 10 shows a ray of light travelling from glass to air.

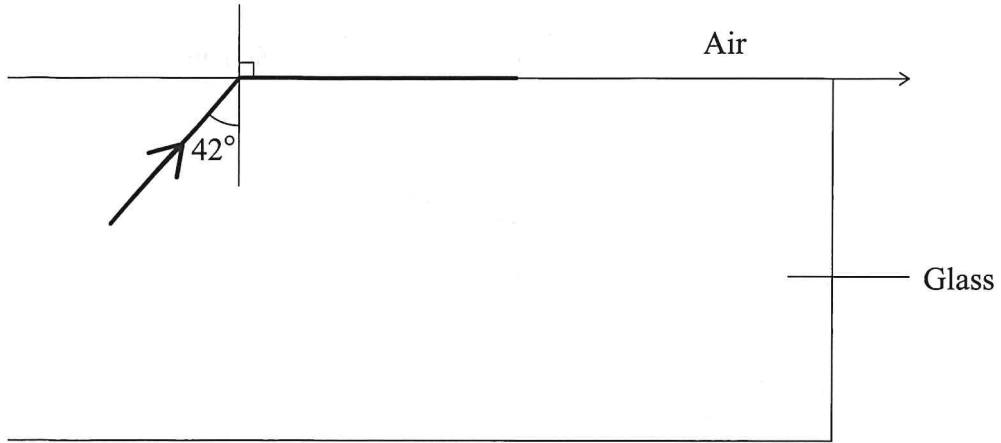

Figure 10

determine the:

- (i) critical angle of the glass – air interface (1 mark)

.....

.....

.....

- (ii) refractive index of glass (2 marks)

.....

.....

.....

A piece of metal is embedded at the centre of an ice block 15 cm from the surface of the ice. Given that the refractive index of ice is 1.32, determine how far from the surface of the ice block the metal appears to be. (3 marks)

.....

.....

.....

.....



(c) **Figure 9** shows light rays from two coherent sources S_1 & S_2 . Dark and bright fringes are observed between A and B.

17. (a)

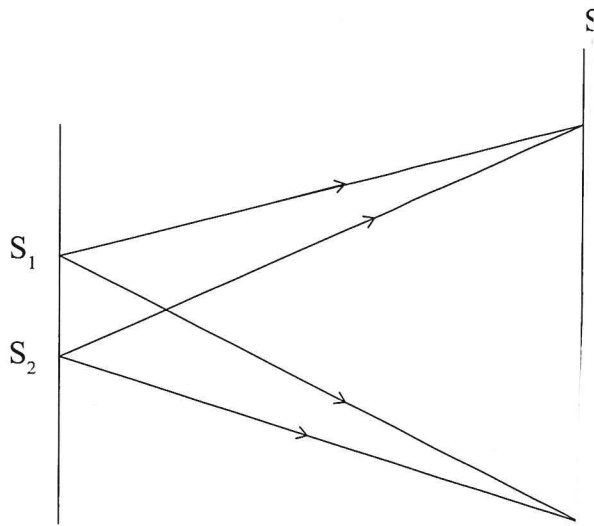

De

Figure 9

(i) State how:

I. bright fringes are formed

.....
.....

II. dark fringes are formed

.....
.....

(ii) State what is observed when light of a higher frequency is used.

.....
.....

(b)

(c) **Figure 11** shows two rays of incident on a diverging lens.

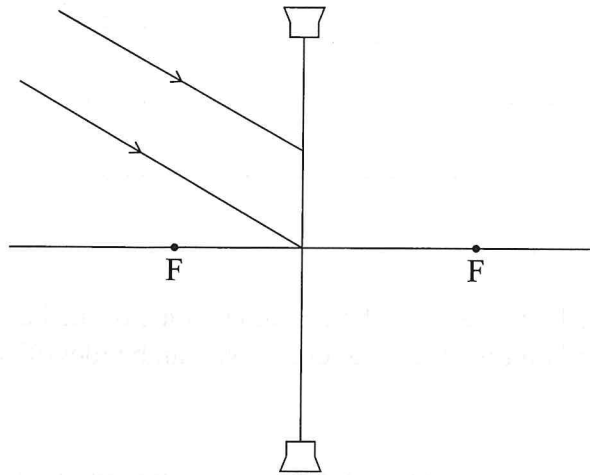

Figure 11

Complete the ray diagram to show the path of the rays after passing through the lens. (2 marks)

(d) (i) State **two** differences between the human eye and a camera lens. (2 marks)

.....
.....
.....
.....

(ii) State the name of the part of the eye that enable the lens to focus images of objects at different distances. (1 mark)

.....

922

0086



18. (a) Describe how a magnet can be demagnetised using the electrical method. (2 marks)

.....

.....

.....

.....

- (b) You are provided with two iron bars P and Q. One of the bars is magnetised while the other is not. Explain how the magnetised bar can be identified without using a magnet or magnetic material. (2 marks)

.....

.....

.....

.....

- (c) **Figure 12** shows **two** identical copper coils X and Y placed close to each other. Coil X is connected to a DC power supply while coil Y is connected to a galvanometer.

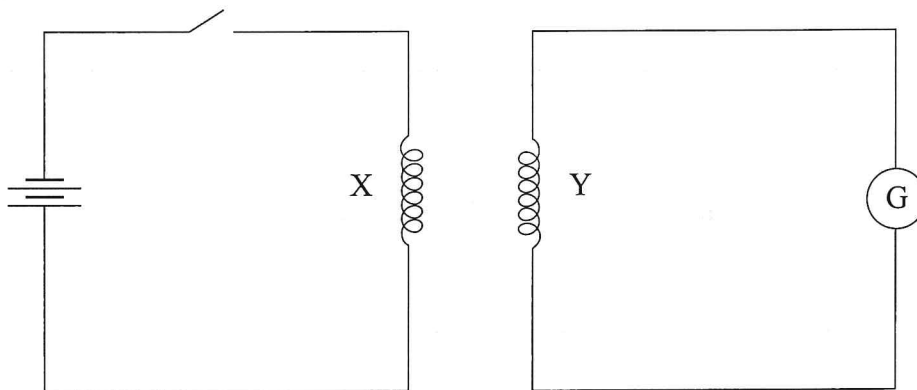

Figure 12

- (i) Explain what is observed on the galvanometer when the switch is closed. (4 marks)

.....

.....

.....

.....

.....

(ii) State what is observed on the galvanometer when the switch is opened. (1 mark)

.....

.....

(iii) State what would be observed if the number of turns in coil Y is doubled. (1 mark)

.....

.....

19. (a) Define *half life* as used in radioactivity. (1 mark)

.....

.....

(b) **Figure 13** shows a device used to detect radioactivity by forming tracks when air is ionised.

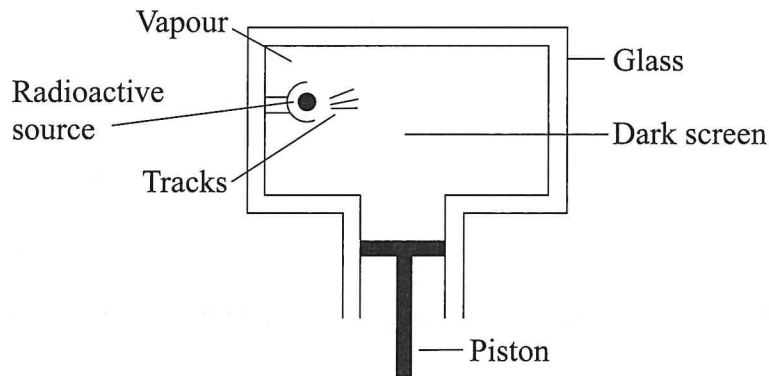

Figure 13

(i) State the name of the device shown. (1 mark)

.....

(ii) State how air in the device gets ionised. (1 mark)

.....

(iii) Describe how tracks are formed. (3 marks)

.....
.....
.....
.....

(c) (i) State **two** factors that determine the speed of the photoelectrons emitted from a metal surface. (2 marks)

.....
.....
.....
.....

(ii) The energy of a photon of light is 2.21 eV. (*electronic charge is $1.6 \times 10^{-19}C$ and planks constant h is $6.63 \times 10^{-34}Js$*).

I. Express this energy in joules. (1 mark)

.....
.....
.....

II. Determine the frequency of the light that produces the photon. (2 marks)

.....
.....
.....
.....

THIS IS THE LAST PRINTED PAGE.

