

1. The electronic arrangement of ions x^{3+} and y^{2-} are 2.8 and 2.8.8 respectively
- Write the electronic arrangement of the elements x and y. (3 marks)
 - Write the formula of the compound that would be formed between x and y. (1 mark)
2. When bromine gas reacts with aqueous Sodium hydroxide, the equilibrium represented by the equation;

$$\text{Br}_2(\text{aq}) + 2\text{OH}^-(\text{aq}) \rightleftharpoons \text{Br}^-(\text{aq}) + \text{OBr}^-(\text{aq}) + \text{H}_2\text{O}$$
 is established.

What observations would be made if a few drops of sulphuric (VI) acid were added to the equilibrium mixture? (2 marks)

3. Calculate the amount of calcium carbonate that would remain if 15.0g of calcium carbonate were reacted with 0.2g moles of hydrochloric acid. The equation for the reaction is,

$$\text{CaCO}_3(\text{s}) + 2\text{HCl} \longrightarrow \text{CaCl}_2(\text{aq}) + \text{CO}_2(\text{g}) + \text{H}_2\text{O}(\text{g})$$
 (C = 12.0, O = 16, Ca = 40.0) (3 marks)
4. In an experiment, soap solution was added to three separate samples of water. The table below shows the volumes of soap solution required to form lather with 1000cm³ of each sample of water before and after boiling.

	Sample 1	Sample 2	Sample 3
Volume of soap before water is boiled	27.0	3.0	10.6
Volume of soap after water is boiled	27.0	3.0	3.0

- Which water sample is likely to be soft? Explain. (2 marks)
 - Explain the change in the volumes of soap solution used in sample (iii). (1 mark)
5. Ammonia gas was passed into water as shown.

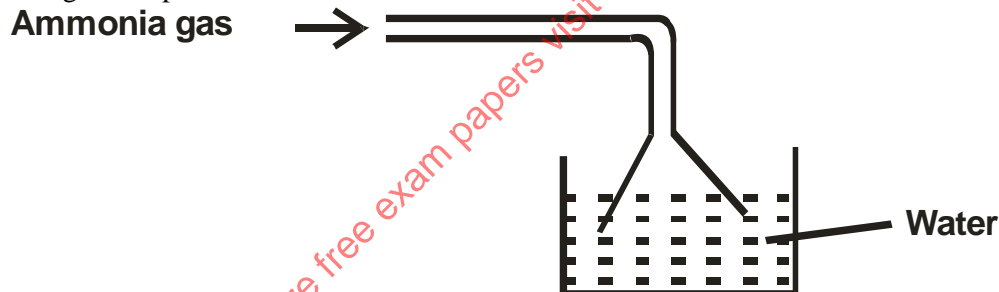

- When a red litmus paper was dropped into the resulting solution, it turned blue. Give a reason for this observation. (1 mark)
 - What is the function of the funnel? (1 mark)
6. The table below gives some properties of gases D and E.
- | Gas | Density | Effects of H ₂ SO ₄ | Effects of NaOH |
|-----|------------------|---|----------------------------|
| D | Lighter than air | Reacts to form a salt | Dissolves without reacting |
| E | Heavier than air | Not affected | Not affected |
- Describe how you would obtain a sample of E from a mixture of gases D and E. (2 marks)
 - Suggest a possible identity of gas D. Give a reason for your answer. (1 marks)

7. The curve below represents the variation of temperature with time when pure and impure samples of a solid were heated separately.

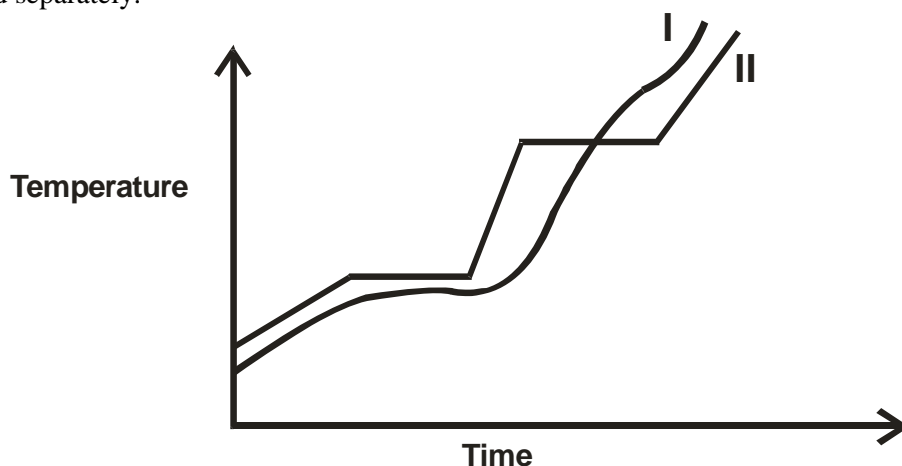

Which curve shows the variation in temperature for the pure solid? Explain.

(2 marks)

8. The diagram below represent set-up that can be used to prepare and collect oxygen gas.

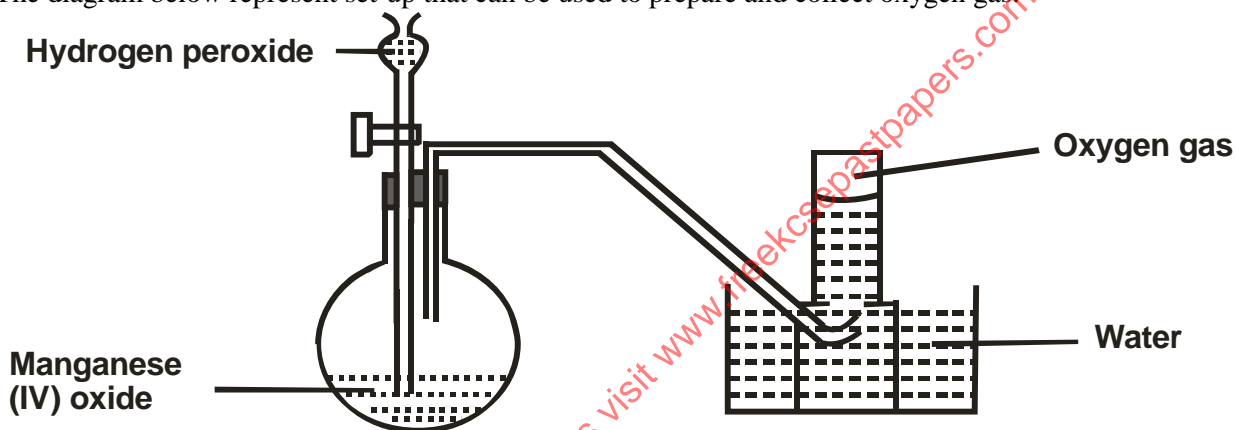

a) Write an equation for the reaction that takes place.

(1 mark)

b) What property of oxygen makes it possible for its collection as indicated by the diagram?

(1 mark)

c) Explain why it is important not to collect gas for the first few seconds of the experiment.

(1 mark)

9. Study the set-up below and answer the questions that follow.

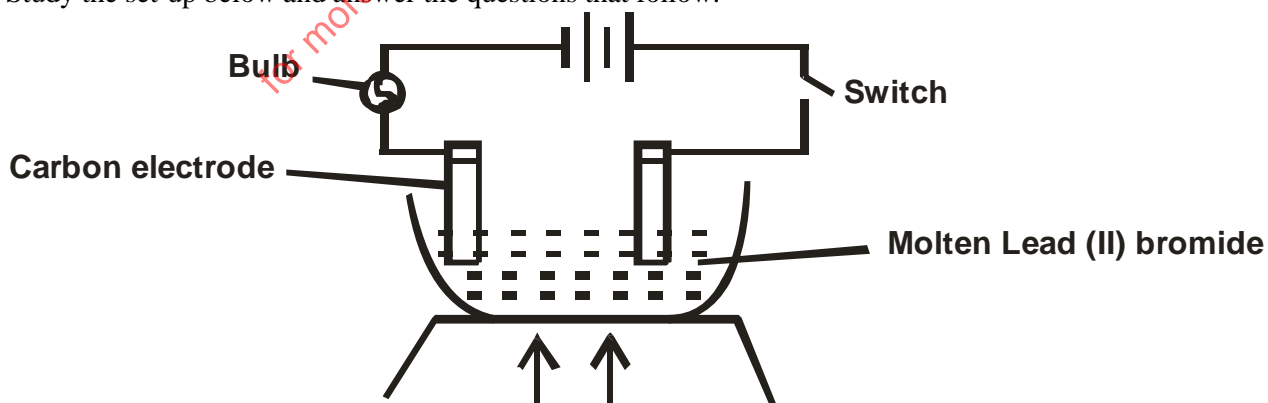

State and explain the observation that would be made when the circuit is completed.

(3 marks)

CHEMISTRY PAPER 1,2 & 3

10. In an experiment, rods of metals P, Q and R were cleaned with sand paper and placed in a beaker containing water. Another set of rods was also cleaned and placed in a beaker containing dilute acid. After placing the rods in the two liquids, bubbles of gas were seen around some of the rods as shown in the diagrams below.

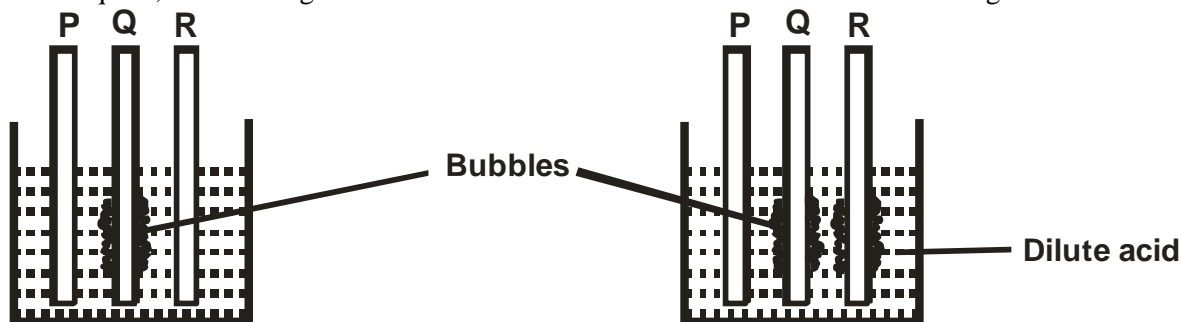

- a) Why is it necessary to clean the rods with sand paper before dipping them into the liquids? (1 marks)
- b) Arrange the three metals in order of their reactivity starting with the most reactive. (1 mark)
11. A solution of chlorine in tetrachloromethane turns colourless when propene gas is bubbled through it.
- a) What type of reaction takes place? (1marks)
- b) Write an equation for the above reaction. (1 mark)
12. With reference to atomic number of one, explain why hydrogen can be placed in either group I and VII of the periodic table. (2 marks)
13. a) Define the term base. (1 mark)
- b) Explain why it is not advisable to use wood ash for cleaning aluminum utensils. (2 marks)
14. A compound has an empirical formula C_3H_6O and a relative formula mass of 116. Determine its molecular formula. (C = 12, O = 16, H = 1) (2 marks)
15. Explain how you would separate mixture of nitrogen and oxygen gases given that their boiling points are $-196^\circ C$ and $-183^\circ C$ respectively. (2 marks)
16. Study the table below and answer the questions that follow.

Alkaline	Formula	Heat of combustion (ΔH_c) $KJmol^{-1}$
Methane	CH_4	-890
Ethane	C_2H_6	-1560
Propane	C_3H_6	-2220
Butane		

- a) Predict the heat of combustion of Butane and write it on the space provided in the table above. (1 mark)
- b) What does the negative sign ΔH_c value indicate about combustion of alkanes? (1 mark)
17. The diagram below represents the extraction of sulphur by Frasch process.

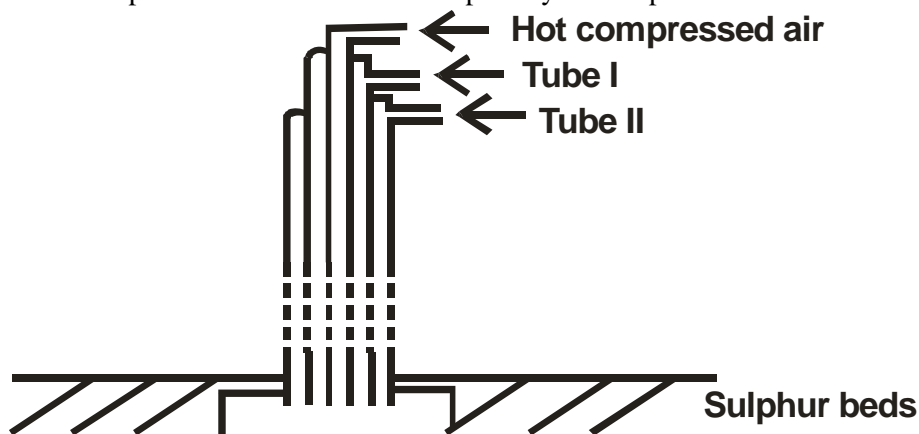

- a) Name the substance that passes through tube I and II. (2 marks)

for more free exam papers visit www.freekcsepastpapers.com

c) What is the purpose of hot compressed air in this process? (1 mark)

18. Study the diagram below and answer the questions that follow.

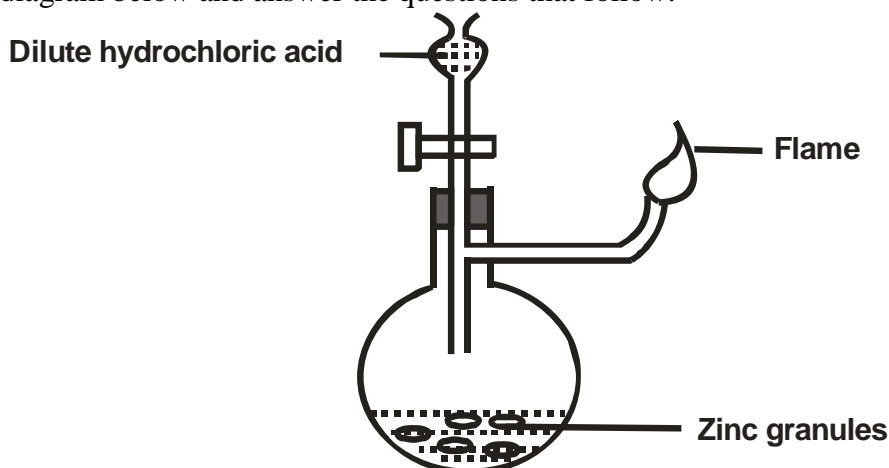

Write an equation for each of the two reactions that take place in the experiment represented by the diagram above. (2 marks)

19. A mixture containing equal volumes of hydrogen gas and carbon (IV) oxide gas was introduced on one end of a tube as shown below.



Which gas would be detected at point C first? Explain. (2 marks)

20. The table below gives three experiments on the reaction of excess sulphuric (VI) acid and 0.5 g of zinc done under different conditions. In each the volume of the gas was recorded at different time interval.

Experiment	Form of zinc	Sulphuric (VI) acid
I	Powder	0.8M
II	Powder	1.0M
III	Granules	0.8M

On the axis below draw and label the three curves that could be obtained from such results. (3 marks)

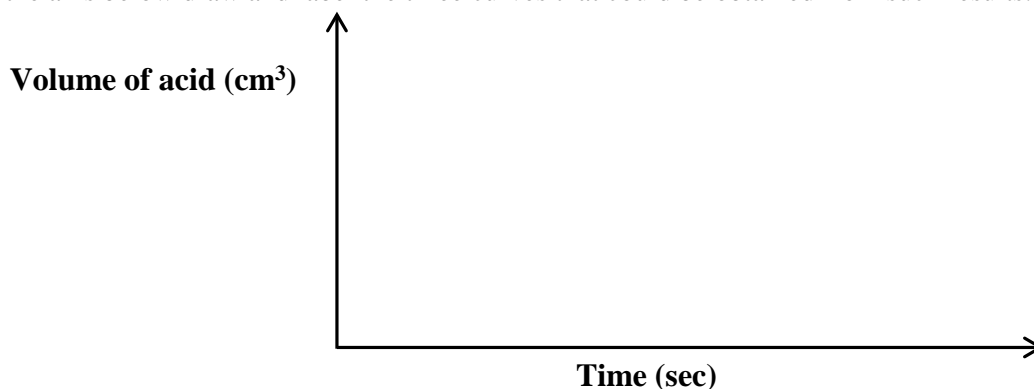

CHEMISTRY PAPER 1,2 & 3

21. The table below shows how solubility of some substances in water varies with temperature

Substance	Change of solubility g/100cm ³ of water with temperature			
	0°C	20°C	40°C	60°C
W	0.334	0.16	0.097	0.0058
X	27.60	34.0	40.0	45.5
Y	35.70	36.0	36.6	37.3

Which of above substances is likely to be a gas? Explain.

(2 marks)

22. Study the chart below and answer the questions that follow.

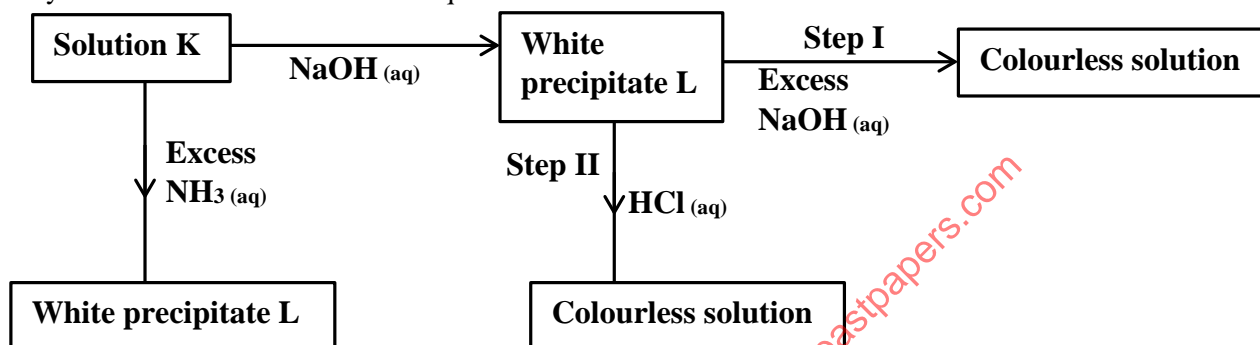

- a) Identify;
- the metal ions in solution K (1 mark)
 - the white precipitate L. (1 mark)
- b) What is the nature of solution K? (1 mark)
23. Explain the following observation. A chloride dissolves in water to form an electrolyte while the same chloride dissolves in methylbenzene to form a non-electrolyte. (2 marks)
24. State what would be observed when dilute hydrochloric acid is added to the products formed from a mixture of iron filings and sulphur. (2 marks)
25. Describe how the following reagents can be used to prepare lead (II)sulphate; solid potassium sulphate, solid lead (II) carbonate, dilute nitric (V) acid and distilled water. (2 marks)
26. Explain why the enthalpy of neutralisation of ethanoic acid with sodium hydroxide is different from that of hydrochloric acid with sodium hydroxide. (2 marks)
27. Give a reason why calcium hydroxide solution is used to detect the presence of carbon (IV) oxide gas while sodium hydroxide solution is NOT. (2 marks)
28. A compound C₂H₂ reacts with hydrogen in presence of nickel catalyst to form another compound C₂H₄. The same compound C₂H₂ reacts with hydrogen to form C₂H₆ in presence of nickel catalyst.
- Draw the structural formula and name the compound C₂H₄. (1 mark)
 - Write the equation for the reaction between C₂H₄ and hydrogen. (1 mark)
29. During the production of hydrogen Iodide, hydrogen reacts with Iodine according to the equation.
- $$\text{H}_{2(g)} + \text{I}_{2(g)} \rightleftharpoons 2 \text{HI}_{(g)} \quad \Delta H +52\text{KJ}$$
- Explain how the following would affect the yield of hydrogen Iodide. (2 marks)
- Increase in temperature
 - Increase in pressure
30. a) Using dots (•) and crosses (x) to represent electrons, draw diagrams to represent the bonding in;
- NH₃
 - NH₄⁺
- b) State why an ammonia molecule (NH₃) can be combined with H⁺ to form NH₄⁺ (atomic numbers N = 7 and H = 1) (1 mark)

CHEMISTRY PAPER 1,2 & 3

31. The table below gives the atomic numbers of elements W, X, Y and Z.
The letters do not represent the actual symbols of the elements.

Element	W	X	Y	Z
Atomic number	9	10	11	12

- a) Which one of the elements is least reactive? (1 mark)
- b) i) Which two elements would react most vigorously with each other? (1 mark)
 ii) Give the formula of the compound formed when elements in b) (i) reacts. (1 mark)
32. When magnesium metal is burnt in air it reacts with both oxygen and nitrogen gases giving a white ash.
- a) Write two equations for the reaction that take place. (2 marks)
- b) When the white ash in (a) above is mixed with water, a gas with a pungent smell is produced. Write an equation for this reaction. (1 mark)
33. In an experiment to separate a mixture of two organic liquids, liquid M (boiling point of 56°C) and liquid N (boiling point of 118°C). A student set up the apparatus as shown below

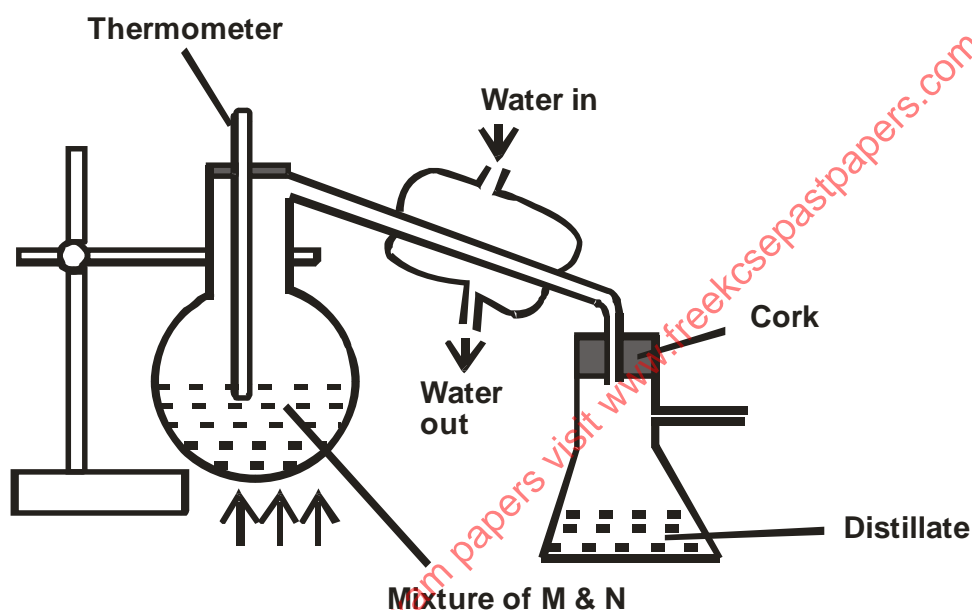

- a) Identify **two** mistakes in the set-up. (2 marks)
- b) What method would the student use to test the purity of the distillates obtained? (1 mark)

MERU
233/2
CHEMISTRY
PAPER 2
(THEORY)

1. The grid below represents part of the periodic table. Study it and answer the questions that follow.
 The letters are not the actual symbols of the elements.

		F	J	H
B	E		L	K
	C	G		
D				

- i. Select the most reactive non-metal. Explain. (2 marks)
 - ii. Identify an element that can form an amphoteric hydroxide. (1 mark)
 - iii. Which group one element has the lowest first ionization energy? Explain. (2 marks)
 - iv. Name the other group to which element A can be placed and give a reason. (2 marks)
 - v. Compare the atomic size of elements C and G. Explain. (2 marks)
 - vi. Write the electronic configuration of the ion formed by element L and indicate its symbol. (1 mark)
 - vii. i) Using dots (•) and crosses (x) to represent electrons, show the bonding in the compound formed between elements B and J. (1 mark)
 - ii) Identify an element that is not likely to form any type of bond. Explain. (1 mark)
2. a) Study the reaction scheme below and answer the questions that follow.

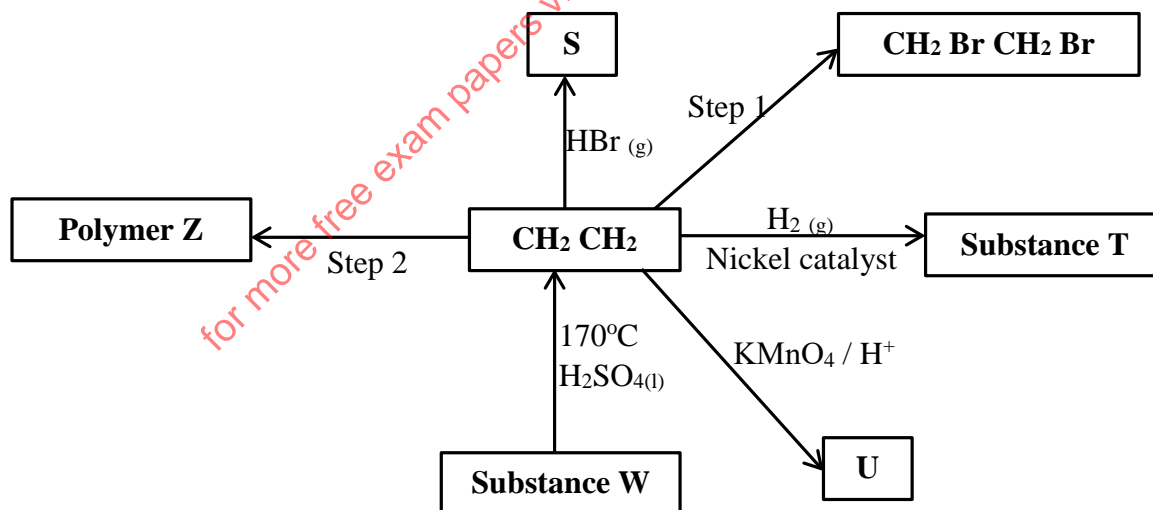

- i) Name the substances; S, T, U and W. (2 marks)
 - ii) Name the reagent for step 1. (1 mark)
 - iii) Draw the polymer Z comprising of three monomers. (1 mark)
 - iv) Name the type of polymerisation on step 2. (1 mark)
- b) Draw the structures of the following compounds.
- i. 2-bromo-3, 3-dimethylpent-1-ene. (1 mark)
 - ii. 1, 2-dichloroethyne. (1 mark)

for more free exam papers visit www.freekcsepastpapers.com

C) Name the following organic compounds.

i.

1 mark

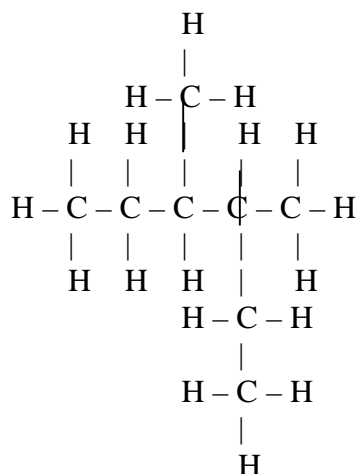

(1

ii. $\text{CH}_3\text{CHCl}(\text{CH}_2)_2\text{C}(\text{CH}_3)_2\text{CH}_2\text{CH}_3$

(1 mark)

d) Draw and name two positional isomers of pentyne.

(2 marks)

3. The flow chart below shows how sulphuric (VI) acid is produced on a large scale.

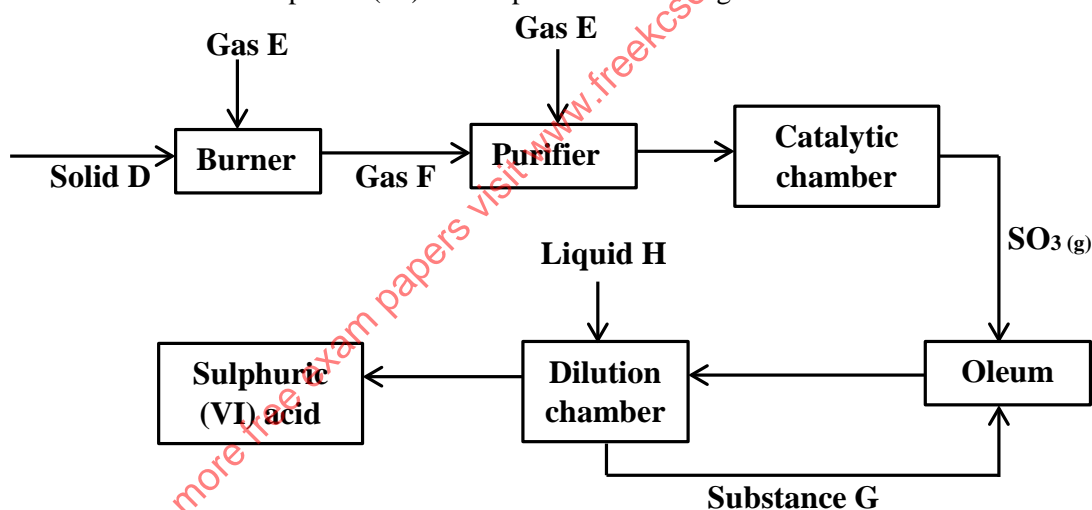

a) Identify the following;

i) Gas E

(½ mark)

ii) Gas F

(½ mark)

iii) Solid D

(½ mark)

iv) Substance G

(½ mark)

v) Liquid H

(½ mark)

b) Name the most preferred catalyst used in the catalytic chamber and give a reason.

(1½ marks)

c) Write an equation for the reaction that forms oleum.

(1 mark)

d) Explain the importance of the purifier.

(2 marks)

e) State **two** ways how pollution is controlled during the process of manufacturing sulphuric (VI) acid.

(2 marks)

f) State **one** industrial application of sulphuric (VI) acid.

(1 mark)

g) What is the name given to the industrial process of manufacturing sulphuric (VI) acid?

(1 mark)

4. The diagram below shows the preparation of Iron (III) chloride salt in the laboratory. Study it and answer the questions that follow.

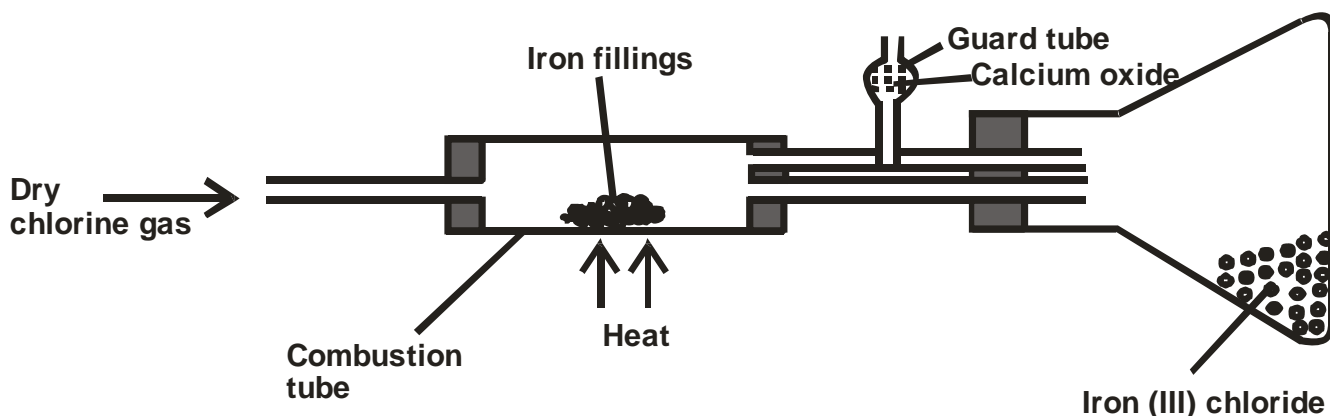

- a) Name the method of preparing Iron (III) chloride salt shown above. (1 mark)
- b) Explain why;
- It is necessary to pass chlorine gas through the apparatus before heating begins. (1 mark)
 - Calcium oxide is more preferred in the guard tube than calcium chloride. (2 marks)
- c) i) What property of Iron (III) chloride makes it possible to be collected as shown in the diagram. (½ mark)
- Name another substance which has the same property as Iron (III) chloride. (½ mark)
- d) Write an equation of the reaction which takes place in the guard tube. (1 mark)
- e) Explain why all dry apparatus and conditions are preferred in the experiment above. (1 mark)
- f) The total mass of Iron (III) chloride formed was found to be 0.5g. Calculate the volume of chlorine gas that reacted with Iron. (Fe = 56, Cl = 35.5, Molar gas volume = 24000cm³) (3 marks)
- g) When hydrogen sulphide gas was passed through a solution of Iron (III) chloride, the following observation were made; red-brown solution changed to green and a yellow solid deposited. Explain this observation. (2 marks)
5. a) State the Hess's law. (1 mark)
- b) Study the equations below and answer the questions that follow.
- $C_{(s)} + O_{2(g)} \longrightarrow CO_{2(g)}$ $\Delta H_1 = - 393 \text{ kJmol}^{-1}$
 - $H_{2(g)} + \frac{1}{2}O_{2(g)} \longrightarrow H_2O_{(l)}$ $\Delta H_2 = - 286 \text{ kJmol}^{-1}$
 - $C_3H_{8(g)} + 5O_{2(g)} \longrightarrow 3CO_{2(g)} + 4H_2O_{(l)}$ $\Delta H_3 = - 2209 \text{ kJmol}^{-1}$
- Name **two** heat changes represented by ΔH_1 (2 marks)
 - Calculate the heat of formation of propane from the equations above, using the energy cycle diagram. (3 marks)
 - Draw the energy level diagram for equation III. (2 marks)
6. a) Candle wax is a compound comprising of two elements. Name them. (2 marks)
- b) The set-up below was used to investigate the burning of a candle. Study it and answer the questions that follow.

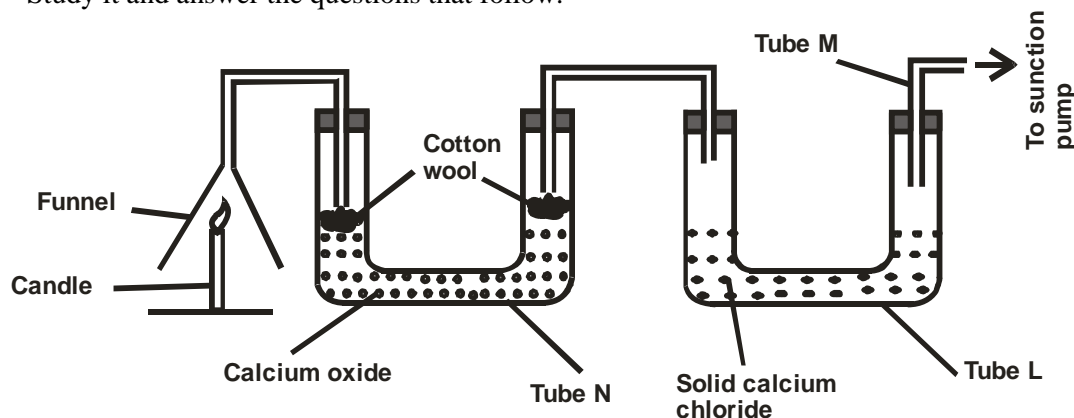

- i. What would happen to the burning candle if the suction pump was turned off. Explain. (2 marks)
 - ii. Explain the purpose of calcium oxide in tube N? (2 marks)
 - iii. What is the role solid calcium chloride in tube L.? (1 mark)
 - iv. Name another substance that could be used in place of calcium oxide in tube N. (1 mark)
 - v. State **two** gases that came out through tube M. (2 marks)
7. A colourless gas was passed over heated lead (II) oxide and the products of the reactions were collected as shown in the diagram below.

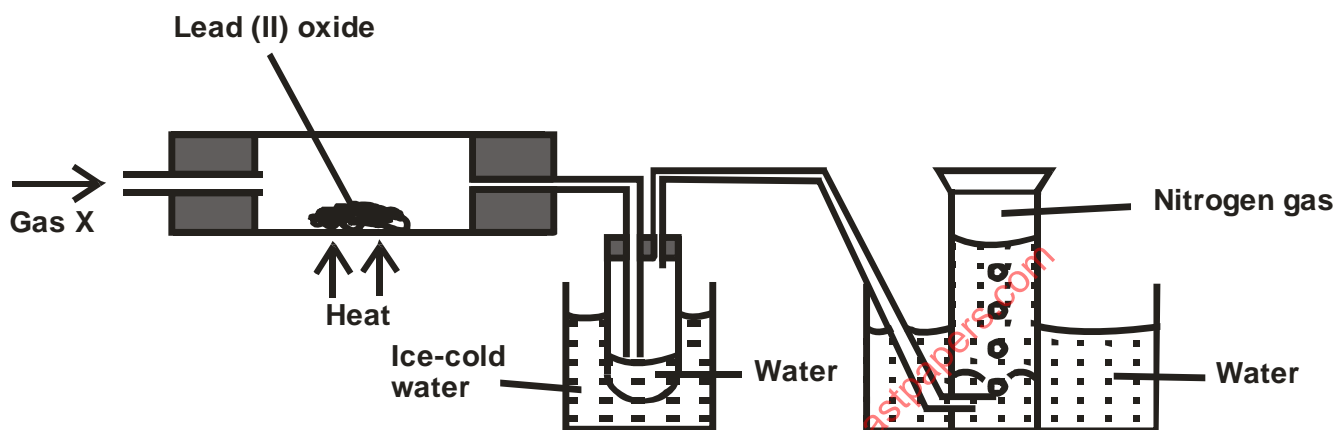

- a) Name gas X. (1 mark)
 - b) State the observation made in the combustion tube. (1 mark)
 - c) What is the purpose of the ice-cold water? (1 mark)
 - d) Write an equation for the reaction that takes place in the combustion tube. (1 mark)
 - e) Why is it possible to collect nitrogen gas as shown in the set up? (1 mark)
 - f) Name the method of obtaining nitrogen gas from air. (1 mark)
8. In an experiment to determine the rate of reaction excess lumps of calcium carbonate were added to 2M hydrochloric acid. The mass of calcium carbonate left was recorded after every 30 seconds.

The results are shown in the table below.

Time (seconds)	0	39	60	90	120	150	180	210
Mass of calcium carbonate left	2.00	1.60	1.30	1.00	0.85	0.80	0.80	0.80

(g)

- a) Write the equation for the reaction that took place. (1 mark)
- b) On the graph paper provided, plot a graph of mass of calcium carbonate (vertical axis) against time. (3 marks)
- c) From the graph;
 - i. Determine the rate of reaction at the 105th second. (2 marks)
 - ii. Why does the curve level off after some time? (1 mark)
- d) On the same graph sketch a curve for the same reaction using 4M hydrochloric acid and level it. (1 mark)
- e) Explain why the experiment above would not be performed with dilute sulphuric (VI) acid. (2 marks)

for more free exam papers visit www.freekcsepastpapers.com

CHEMISTRY PAPER 1,2 & 3
MERU CENTRAL CLUSTER EXAMS
233/3
CHEMISTRY
PAPER 3
(PRACTICAL)

1. You are provided with
 - 3.15g of solid A
 - 0.1M Sodium carbonate (solution B)

You are required to determine

- a) The solubility of A at different temperatures
 b) The number of moles of water of crystallisation in solid A.

PROCEDURE 1

- a) Using a burette add 4cm³ of distilled water to solid A in a boiling tube. Heat the mixture while stirring with the thermometer until all the solid dissolves.
 Allow the solution to cool in air while stirring with the thermometer
 Note the temperature at which crystals of A appear and record in the table 1 below
- b) Using a burette, add 2cm³ of distilled water to the content of the boiling tube, warm the mixture while stirring with the thermometer until all the solid dissolves. Allow the solution to cool while stirring and record the temperatures at which crystals appear.
- c) Complete the table 1 by calculating the solubility of solid A at different temperatures
NB: Keep the content of the boiling tube for procedure 2.

Table 1

Volume of water in the boiling tube	Temperature at which crystals appear	Solubility of A g/100g of water
4		
6		
8		
10		
12		

(6 marks)

- I) Plot a graph of solubility of A (vertical) axis against temperature. (3 marks)
 II) Using your graph determine the temperature at which 60g of solid A would dissolve in 100g of water. (1 mark)

PROCEDURE 2

- a) Transfer the content of the boiling tube into a 250ml volumetric flask.
 b) Add distilled water upto the mark and label this solution A.
 c) Fill the burette with solution B.
 d) Using a clean pipette transfer 25ml of solution B into a conical flask, add 2 – 3 drops of methyl orange indicator.
 e) Titrate A against B until the colour changes to pink.
 f) Record your results in the table 2 below.
 g) Repeat C to F two more times.

Table 2

	I	II	II
Final burette reading (cm ³)			

CHEMISTRY PAPER 1,2 & 3

Initial burette reading (cm³)

Volume of solution A used (cm³)

(4 marks)

- a) Determine the average volume of solution A used. (1 mark)
- b) How many moles of sodium carbonate were used? (1 mark)
- c) If 1 mole of A reacts with 1 mole of Na₂CO₃, how many moles of A were used? (1 mark)
- d) Determine the molarity of solution A. (1 mark)
- e) Determine the molar mass of solid A. (1 mark)
- f) If the formula of A is (COOH)₂.XH₂O. Determine the value of X. (C = 12, O = 16, H = 1) (2 marks)

2. You are provided with solid C. Use it to carry the tests outlined below.

Dissolve the whole of C into 10cm³ of distilled water and divide the resulting solution into 5 portions.

a) To the first portion add dilute hydrochloric acid.

Observations	Inferences
(1 mark)	(2 marks)

b) To the second portion add sodium hydroxide dropwise until in excess.

Observations	Inferences
(1 mark)	(1 mark)

c) To the third portion add sodium sulphate solution.

Observations	Inferences
(1 mark)	(1 mark)

d) To the fourth portion add Lead (II) nitrate solution.

Observations	Inferences
(1 mark)	(1 mark)

e) To the last portion add Barium Nitrate solution.

Observations	Inferences
(1 mark)	(1 mark)

3. You are provided with solid D. Use it to carry the tests outlined below.

a) Ignite $\frac{1}{3}$ of solid D in a metallic spatula using a non-luminous flame.

Observations	Inferences
(1 mark)	(1 mark)

b) To the remaining solid D in the test tube, add 6cm³ of distilled water and divide the resulting mixture into 3 portions.

i) To the first portion add solid sodium hydrogen carbonate.

CHEMISTRY PAPER 1,2 & 3

Observations	Inferences
(1 mark)	(1 mark)

for more free exam papers visit www.freekcsepastpapers.com

ii) To the second portion add acidified KMnO_4 (potassium manganate (VII)).

Observations	Inferences
(1 mark)	(1 mark)

iii) To the last portion add bromine water.

Observations	Inferences
(1 mark)	(1 mark)

for more free exam papers visit www.freekcsepastpapers.com

CHEMISTRY PAPER 1,2 & 3
LANGATA/DAGORETTI C LUSTER
233/1
CHEMISTRY
(THEORY)
PAPER 1

1. A Student in form four placed a thermometer in molten naphthalene at 85°C and recorded the temperature and time until the naphthalene solidified. From the values obtained, the figure below was drawn.

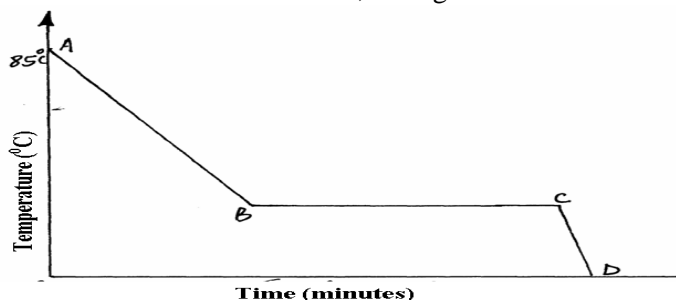

- (a) What name is given to such a figure?..... (1mk)
 (b) Which part of the figure represents the change of state of naphthalene?..... (1mk)
 (c) In terms of kinetic theory. Explain what happens to molecules along AB. (1mk)
2. In a certain reaction, 18.7cm³ of a dibasic acid H_2X required 25cm³ of 0.1M NaOH for complete neutralization.
- (a) How many moles of Sodium hydroxide are contained in 25cm³? (1mk)
 (b) Calculate the molarity of the dibasic acid. (2mks)
3. Study the flow chart below and answer the questions that follow.

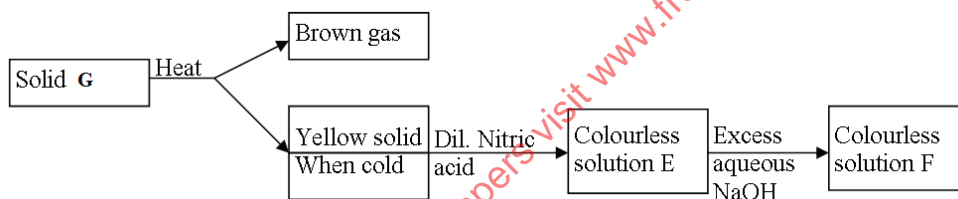

- (a) Identify solid G (1mk)
 (b) Write a balanced chemical equation between the yellow solid and dilute nitric acid. (1mk)
 (c) Write the formula of the complex ion in solution F (1mk)
4. Explain this observation:
 When hydrogen chloride gas is dissolved in water, the solution conducts electricity while a solution of hydrogen chloride gas in methyl benzene does not conduct electricity. (2mks)
5. Matter exists in three states which can be related as shown in the diagram below.

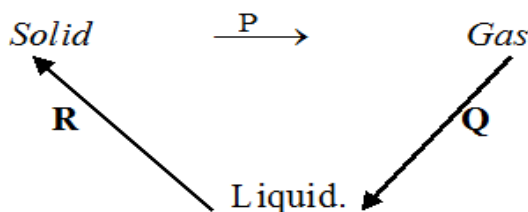

- (a) Name processes: P: (1mark)
 R: (1mark)
- (b) Explain whether process Q is exothermic or endothermic (1mark)

CHEMISTRY PAPER 1,2 & 3

6. (a) What is meant by allotropy? (1mark)
 (b) Name two allotropes of carbon. (1mark)
 (c) Give one use of charcoal in the sugar refinery industry. (1mk)
7. (a) State Graham's Law of Diffusion (1mk)
 (b) A given volume of ozone (O₃) diffused from a certain apparatus in 96 seconds. Calculate the time taken by an equal volume of carbon(IV) oxide to diffuse under the same conditions. (C=12,O=16) (2mks)
8. (a) Name two ores from which copper is extracted. (1mk)
 (b) During the extraction of copper metal the ore is subjected to froth floatation. Give a reason why this process is necessary. (1mk)
 (c) One of the alloys of copper is brass. State its two uses. (1mk)
9. Draw a dot (●) and cross (X) diagram to show bonding in sulphur (IV) oxide (1mk)
10. A form one class carried out an experiment to determine the active part of air. The diagram below shows the set-up of the experiment and also the observation made.

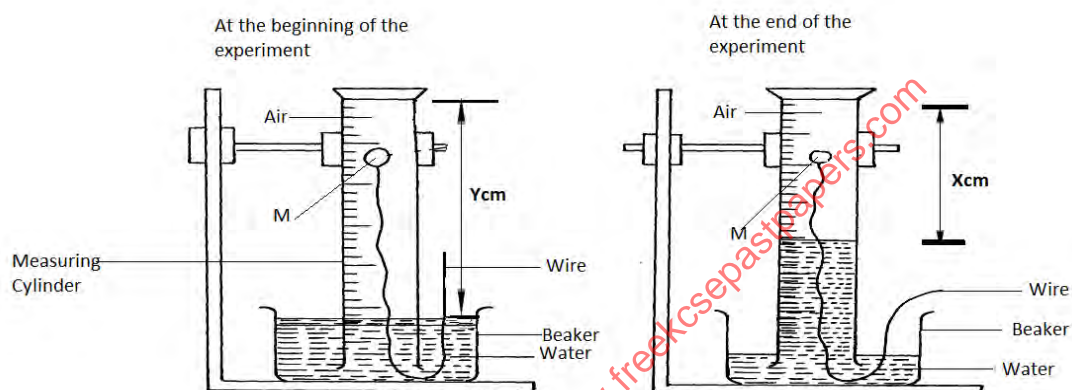

- (a) Identify substance M (1mk)
 (b) State two reasons for the suitability of substance M for this experiment (1mk)
 (c) Write the equation for the reaction of substance M and the active part of air (1mk)
11. (a) Complete the following equation (1mk)

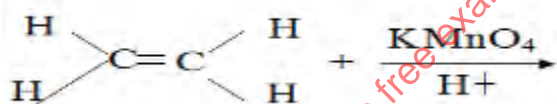

- (b) Name the homologous series to which the following compounds belong?
 (i) CH₃CCH (1mk)
 (ii) CH₃CH₂OOCCH₃ (1mk)
12. The table below shows the pH values of solutions J to N

Solution	J	K	L	M	N
pH	5	13	2	10	7

- (a) Which solution contains the largest concentration of hydroxides ions? (1mk)
 (b) Which solution is likely to be a solution of acetic acid? (1mk)

13. The scheme below was used to prepare a cleansing agent. Study it and answer the questions that follow.

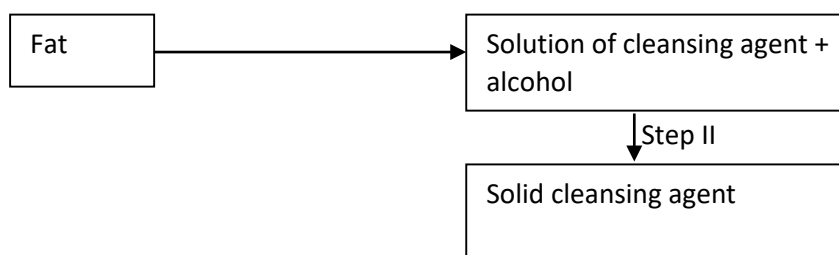

- (i) What name is given to the type of cleansing agent prepared by the method shown in the scheme? (1mk)
- (ii) Name one chemical substance added in step II (1mk)
- (iii) What is the purpose of adding the chemical substance named in (ii) above. (1mk)
14. a) Define half – life of radio isotopes. (1mk)
- b) Z grammes of a radioactive isotope take 100 days to decay to 20gms. If the half – life of the element is 25 days. **Calculate** the initial mass of Z of the radio- isotope. (2mks)
15. Magnesium was burnt in air forming a white residue T. When put in a boiling tube with water effervescence was noticed and colourless gas D with a characteristic pungent smell was evolved. The gas turned a wet red litmus paper blue.
- (a) **Identify**
- (i) Residue T (1mk)
- (ii) Gas D..... (1mk)
- (b) **Write** an equation for liberation of gas D. (1mk)
16. Explain why the bleaching action of chlorine is permanent while bleaching by sulphur (IV) oxide is temporary. (2marks)
17. Explain how you would separate a mixture of nitrogen and oxygen gases given that their boiling points are -196°C and -183°C respectively. (3mks)
18. Hydrazine gas, shown below, burns in oxygen to form nitrogen gas and steam.



- (a) Write an equation for the reaction (1mk)
- (b) Using the bond energies given below, calculate the enthalpy change for the reaction in (a) above (2mks)

Bond	Bond energy KJ per mole
$\text{N} \equiv \text{N}$	944
$\text{N}=\text{N}$	163
$\text{N}-\text{H}$	388
$\text{O}=\text{O}$	496
$\text{H}-\text{O}$	463

19 Using reagents provided only, explain how you could prepare solid Zinc carbonate. (2mks)

- Zinc powder
- Nitric (V) acid (dilute)
- Water
- Solid sodium carbonate

20 The apparatus below was set up to show the catalytic oxidation of ammonia.

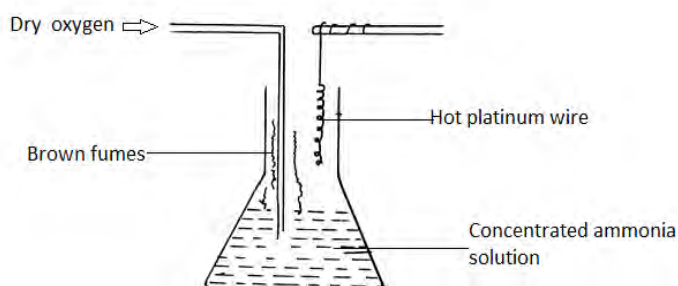

- (a) Identify the brown fumes observed at the mouth of the conical flask. (1mk)
- (b) Write down the equations of the reactions representing
- (i) Catalytic oxidation of ammonia (1mk)
 - (ii) The formation of the brown fumes. (1mk)

21 Consider the chromatogram below.

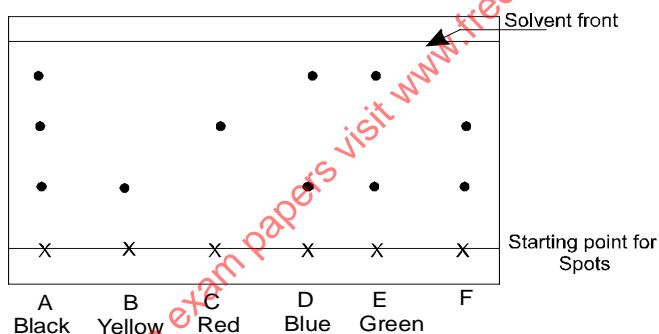

A piece of chromatogram paper was spotted with colour inks obtained from pens labeled A to F. The diagram above shows the spots after the chromatograph was developed.

- (a) Which two pens contained the same pigment? (1mk)
- (b) According to the chromatogram which pigments are present in the inks of the pen number F (1mk)
- (c) Describe how one could get a sample of yellow pigment (1mk)

22. Consider the following reaction at equilibrium.

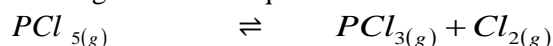

Complete the table below to show the effect of different factors on the position of equilibrium (3mks)

Factor	Effect on the equilibrium position
(i) Decrease pressure	
(ii) Removing chlorine	
(iii) Adding Helium gas to mixture	

23. A student investigated the effect of an electric current by passing it through some substances. The student used inert electrodes and connected a bulb to the circuit. The table below shows the substances used and their states.

CHEMISTRY PAPER 1,2 & 3

Experiment	Substance	State
1	Potassium carbonate	Solid
2	Copper (II) sulphate	Solution
3	Sugar	Solution
4	Lead (II) iodide	Molten

- (a) In which experiments did the bulb not light? (1mk)
 (b) Explain your answer in (a) above. (2mks)
24. Give a reason why the formula mass of NO_2 is sometimes 92 instead of 46. (1mk)

25. A compound contains only carbon, hydrogen and oxygen. Combustion of 1.068g of the compound produces 1.601g of carbon (IV) oxide and 0.437g of water. The molar mass of the compound is 176.1g/mol. What is the empirical and molecular formulae of the compound? (2mks)

26. (a) A sample of water in a beaker was found to boil at 102°C at 1 atmospheric pressure. Assume that the thermometer was not faulty explain this observation (1mk)

(b) Study the information in the table below and answer the questions that follow.

Salt	Solubility (g/100g water)	
	At 40°C	At 60°C
CuSO_4	28	38
$\text{Pb}(\text{NO}_3)_2$	79	98

A mixture containing 35g of CuSO_4 and 78g of $\text{Pb}(\text{NO}_3)_2$ in 100g of water at 60°C was cooled to 40°C

- (i) Which salt crystallized out? Give a reason. (1mk)
 (ii) Calculate the mass of the salt that crystallized out. (1mk)
27. A student was asked to determine the percentage of zinc metal in a mixture of zinc metal and zinc oxide. He reacted the mixture with excess hydrochloric acid and accurately collected the gas evolved, which was then used to calculate the amount of zinc in the mixture.
- (a) Name the gas that was evolved..... (1 mark)
 (b) Apart from the reaction liberating the gas write a balanced equation for the other reaction that took place. (1 mark)
 (c) Why would dilute nitric acid not be suitable for this reaction? (1 mark)
28. Below is part of the flow diagram of the contact process.

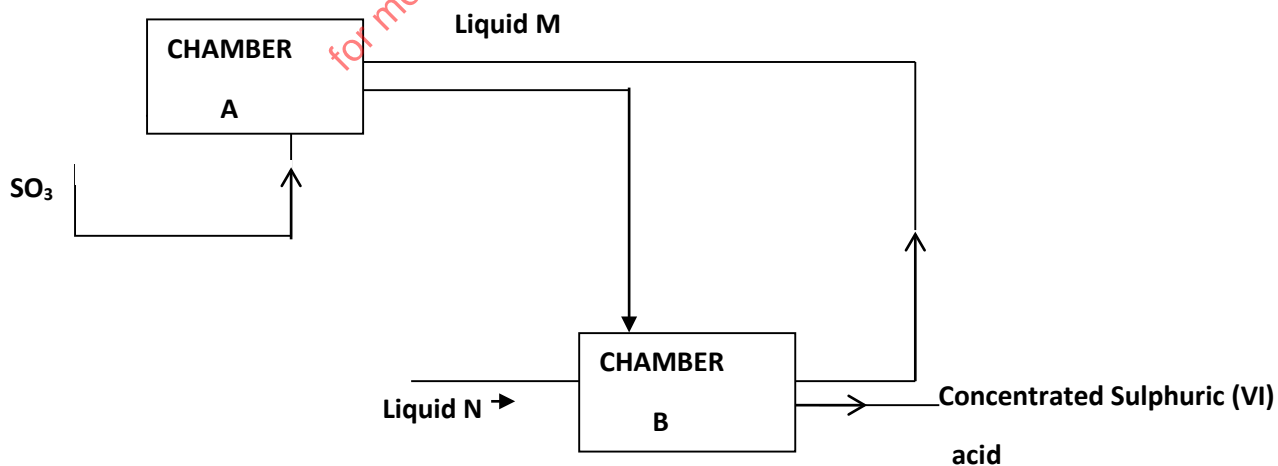

- (a) Identify (i) Liquid M..... (1mk)
(ii) Liquid N..... (1mk)
- (b) Write the equation for the reaction taking place in chamber B. (1mk)
29. Chlorine gas dissolved in distilled water to form chlorine water
(a) Name the compounds present in the chlorine water. (1mk)
(b) What would be observed if blue litmus paper is dipped in chlorine water? Explain. (2mks)
30. A fixed mass of gas occupies 105cm^3 at -14°C and 650mmHg pressure. At what temperature will it have a volume of 15cm^3 if the pressure is adjusted to 690 mmHg pressure (2mks)

LANGATA/DAGORETTI CLUSTER

233/2

CHEMISTRY**Paper 2****THEORY**

1. The grid below represents part of the periodic table. Study it and answer the questions that follow. The letters do not represent the actual symbols of the element.

				N		S		
K	Q		O			P	F	M
	R							

- a) What name is given to the group of elements to which Q and R belong? (1 mark)
- b) Write the formula of the compound formed when Q and P combine. (1 mark)
- c) Name the type of bond formed in (b) above. (1 mark)
- d) How does the atomic radii of O and P compare? Give a reason. (2 marks)
- e) Draw a dot (.) and cross (x) diagram for the compound formed between N and F. (1 mark)
- f) Explain how you would obtain a pure sample of the carbonate of K from its mixture with Lead carbonate powder. (2 marks)
- g) Give one use of element M. (1 mark)
- h) The melting point of M is 189°C lower than that of F -102°C . Explain this difference in their melting points. (2 marks)
2. The list below shows the formulae of some organic compounds. Use letters T1 to T6 to answer the questions that follow.
- T₁ – $\text{CH}_3\text{CH}_2\text{CH}_2\text{CH}_2\text{CH}_3$
- T₂ – $\text{CH}_3\text{CH}_2\text{CH}_2\text{COOC}_2\text{H}_5$
- T₃ – $\text{CH}_3\text{CH}_2\text{CH}_2\text{CH}_2\text{OH}$
- T₄ – $\text{CH}_3\text{CH}_2\text{CH}_2\text{COOH}$
- T₅ – $\text{CH}_3\text{CH}_2\text{CHCH}_2$
- T₆ – CH_3CCCH_3
- (a) Select two compounds which:
(i) Are not hydrocarbons (1mk)

- (ii) Would decolourise both bromine water and acidified potassium manganite (VII) (1mk)
 (iii) Would produce hydrogen gas when reacted with potassium metal (1mk)
 (b) Select a compound which would produce bubbles of a gas when reacted with sodium carbonate. (1mk)
 (c) (i) Identify the compound that is likely to undergo polymerization. Give a reason for your answer. Using two molecules show how polymerization occurs.
- I. Compound (1mk)
 II. Reasons (1mk)
 III. Polymerization (1mk)

(iv) Name the process by which compound T₂ is formed and identify the compounds that were used to form it.

- I. Process (1mk)
 II. Compounds (1mk)

(d) Compound T₃ can be converted to T₄ as shown by the equation below:

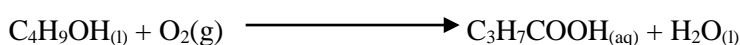

Given the following information:

$$\Delta H_c \text{ for } \text{C}_4\text{H}_9\text{OH} = -4910 \text{ kJ/mol}$$

$$\Delta H_c \text{ for } \text{C}_3\text{H}_7\text{COOH} = -4090 \text{ kJ/mol}$$

Determine the heat change for the reaction above.

(2mks)

3. a) What is meant by the term molar enthalpy of combustion? (1mks)

b) The enthalpies of combustion of carbon, hydrogen and ethanol are given below.



- i) Draw an energy cycle diagram that links the enthalpy of formation of ethanol to enthalpies of combustion of Carbon, hydrogen and ethanol. (3 marks)
 ii) Determine the enthalpy of formation of ethanol (1 marks)
 c. An experiment was carried out where different volumes of dilute nitric acid (v) acid and aqueous potassium hydroxide both at 25°C were mixed and stirred with a thermometer.

The highest temperature reached by each mixture was recorded in the table below.

Volume of nitric (V) acid (cm ³)	4	8	12	16	20	24	28	32	36
Volume of potassium hydroxide cm ³	36	32	28	24	20	16	12	8	4
Highest temperature of mixture	19.8	22.2	24.6	27.0	27.0	25.0	23.0	21.0	19.0

Plot a graph of highest temperature (vertical axis) against volume of nitric acid. (horizontal axis) 3mks

Using your graph, determine the;

CHEMISTRY PAPER 1,2 & 3

- i. highest temperature reached (½ marks)
 ii. The volume of the acid that reacted when the highest temperature is reached. (½ marks)
 iii. The amount of heat liberated during the neutralization process
 (Specific heat capacity is $4.2\text{Jg}^{-1}\text{K}^{-1}$ and the density of solution is 1.0gcm^{-3}) (2 marks)
- d) The molar enthalpies of neutralization for dilute hydrochloric acid and dilute nitric (v) acid are -55KJmol^{-1} . while that of ethanoic acid is -52.2kJ/mol . Explain this observation. (2 mks)

4. Experiment was set as shown below.

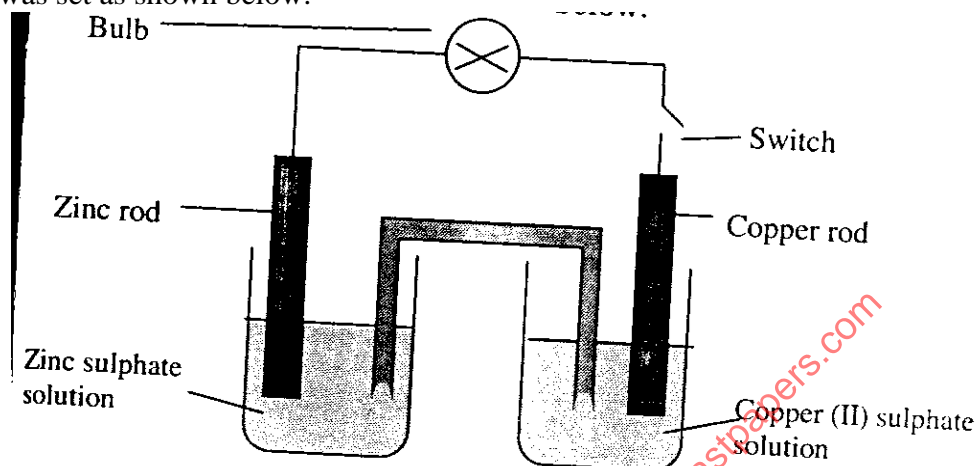

- (a) What is observed on the bulb when the switch is closed? (1mk)
 (b) Which electrode will be cathode? (1mk)
 (c) Write down the half-cell equations for:
 i. Copper electrode. (1mk)
 ii. Zinc electrode. (1mk)
 (d) Write the overall ionic equation for the electrochemical cell. (1mk)

(e) The table below shows the electrode potentials.



What is the value of the voltage of the cell? (2mks)

- (f) The switch is kept closed. State and explain the observation expected after sometime on the
 (i) The zinc rod. (2mks)
 (ii) Copper (II) Sulphate solution. (2mks)

5. The chart below represents the extraction of iron and some of its uses.

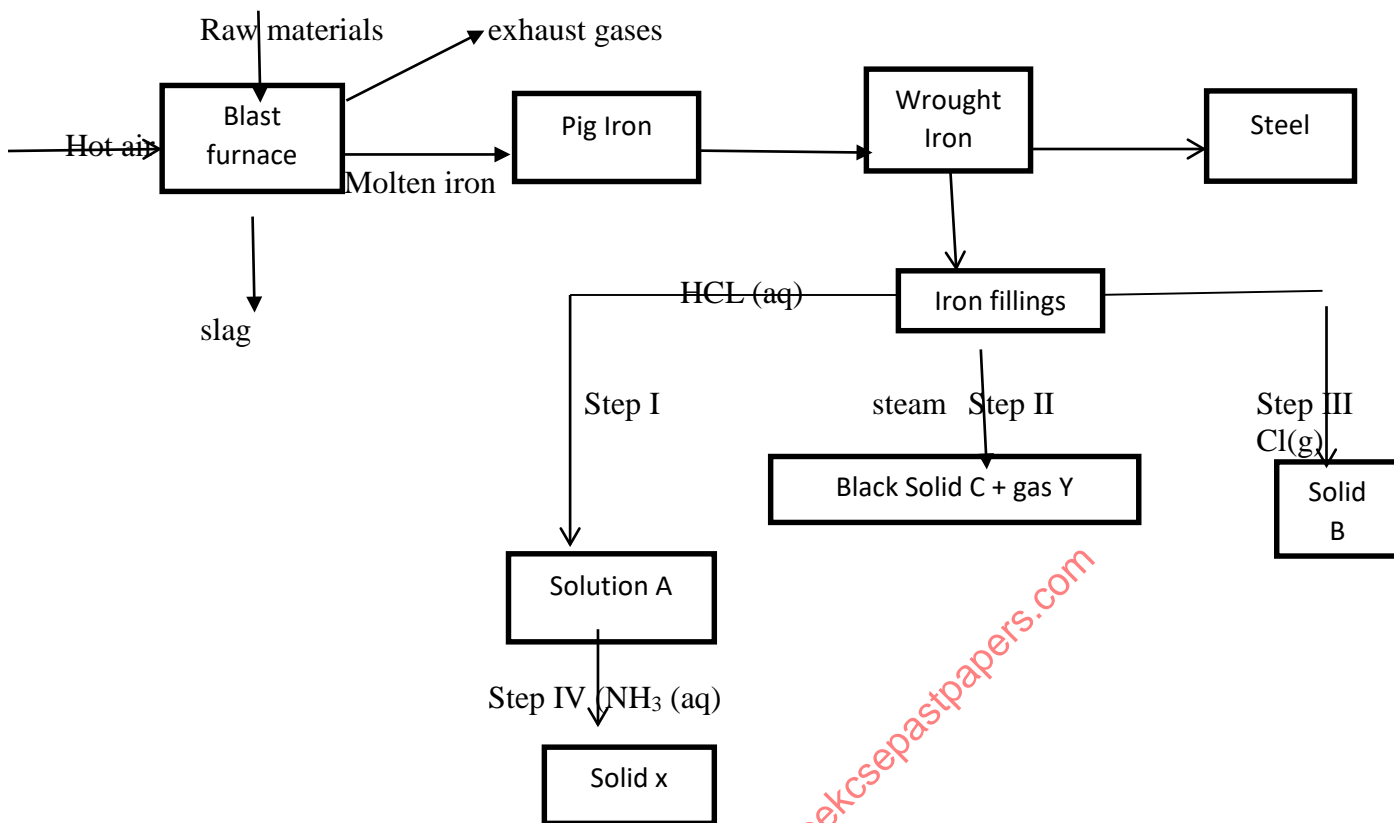

- (a) Name the raw materials fed into the blast furnace. (2mks)
- (b) Name 3 exhaust gases emitted from the blast furnace. (1½mks)
- (c) (i) Why is it necessary to convert pig iron into wrought iron. (1mk)
 (ii) State one commercial use of iron. (1mk)
- (d) Name substances A, B, C, X & Y (2½mks)
- (e) Write equations for reactions in steps
- II (2mks)
 - III (1mk)
 - Write an ionic equation for the reaction in step I. (2mks)
 - What observations are made in steps?
 I
 I

6. Study the flow chart below and answer the questions that follow.

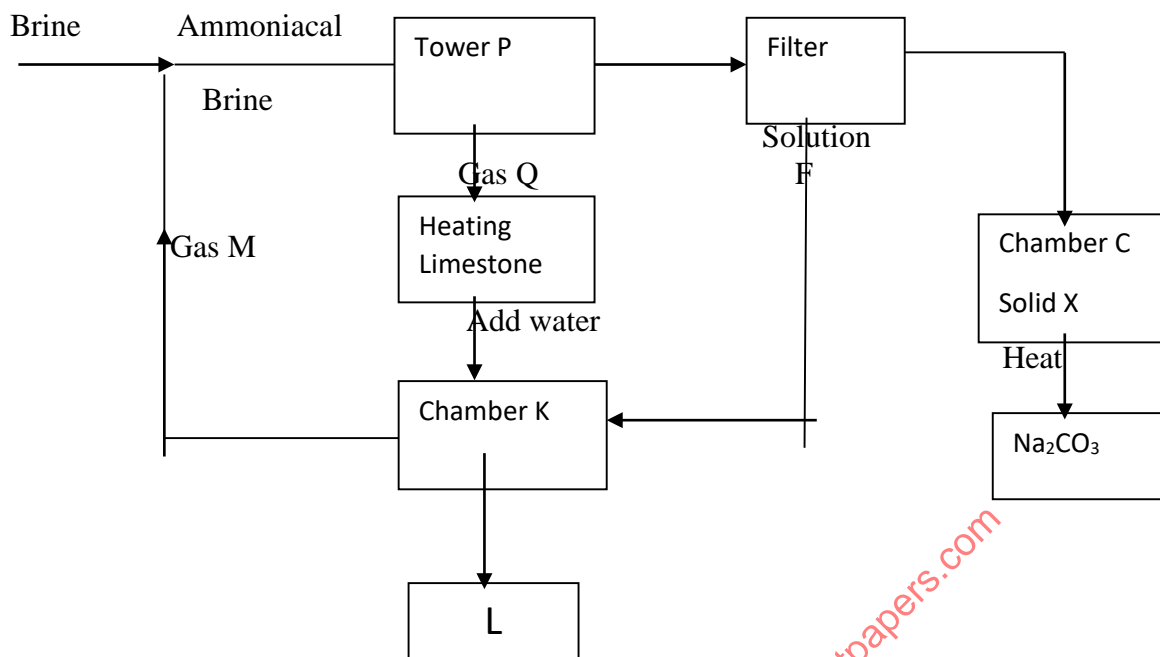

- a) Name Gas M (1 mark)
- b) Name solution F and solid X (1 mark)
- c) Name the product L formed and give one of its uses (2 mark)
- d) Write equation of the reaction in the;
- tower P -
 - chamber K -
- e) Name two raw materials required in the manufacture of Sodium carbonate (2 marks)
- f) Write an equation of the reaction when solid x is heated. (1 mark)
7. The table below shows the volume of nitrogen (IV) Oxide produced when different volumes of 1M Nitric (V) acid – were each reacted with 4.14g of lead at room temperature.

Volume of 1 M Nitric (V) acid (cm ³)	Volume of Nitrogen (IV) oxide gas (cm ³)
10	120
30	360
50	600
70	840
90	960
110	960

- (a) Explain how the rate of the reaction between lead and nitric (V) acid would be affected if the temperature of the reaction mixture was lowered. (1mks)
- (b) On the grid provided below plot a graph of the volume of the gas produced (vertical axis) against volume of acid. (3mks)
- (c) Using the graph, determine the volume of
- Nitrogen (IV) oxide produced when 60cm³ of 1M Nitric (V) acid were reacted with 4.14g of lead. (1mk)
 - 1M Nitric (V) acid which would react completely with 4.14g of lead. (1mk)
- (d) Using the answer in d(ii) above, determine
- The volume of 1M Nitric (V) acid that would react completely with one mole of lead. (Pb = 207). (2mks)

CHEMISTRY PAPER 1,2 & 3

- (e) Calculate the number of moles of
- (i) 1M Nitric (IV) acid reacted with one mole of lead. (1mk)
 - (ii) Nitrogen (IV) oxide produced when one mole of lead were reacted with excess nitric acid. (Molar gas volume is 24000cm^3).
- (f) Using the answers obtained in e(i) and e(ii) above; write the equation for the reaction between lead and nitric (V) acid given that one mole of lead (II) nitrate and two moles of water were produced (1mk)
- (g) Give a reason why nitric (V) acid is stored in dark bottles. (1mk)

LANGATA/DAGORETTI CLUSTER
233/3 CHEMISTRY
PAPER 3
END OF TERM II 2020

(CONFIDENTIAL)

In addition to the apparatus found in the laboratory each candidate will require the following

- About 0.5g of solid F
- About 1g of solid G
- 6 clean test-tubes
- Universal indicator solution and a pH chart
- Ethanol supplied with a dropper
- Clean dry metallic spatula
- 1 boiling tube
- Distilled water
- Solution J, about 130cm^3
- Solution Q, about 160cm^3
- Solution R, about 30cm^3
- Screened methyl orange indicator
- Methyl orange indicator
- 100ml measuring cylinder
- Filter paper
- Means of labeling
- Solid P
- Thermometer
- 100ml beaker

Access to the following;

- ❖ Ethanol supplied with a dropper
- ❖ Concentrated sulphuric (VI) acid supplied with a dropper bottle
- ❖ Acidified Potassium dichromate (VI) solution
- ❖ Acidified Potassium Manganate (VII) solution.
- ❖ 2M $\text{Ba}(\text{NO}_3)_2$ solution.
- ❖ 2M NaOH solution.
- ❖ 2M HCl acid.
- ❖ Source of heat.

Preparation

- ✓ Solution J is 0.12M HCL, prepared by adding about 800cm^3 of distilled water to 4.05cm^3 of concentrated HCL of density 1.08gcm^{-3} and making it to one litre of solution.
- ✓ Solution Q is prepared by dissolving 5.3g of anhydrous sodium carbonate in enough distilled water and making up to one litre of solution.
- ✓ Solution R is prepared by dissolving 15.75g of hydrated barium hydroxide in enough distilled water and top up to one

CHEMISTRY PAPER 1,2 & 3

litre of solution.

- ✓ Solid P is 2.0g of oxalic acid weighed accurately and supplied in a stoppered container
- ✓ Solid F is maleic acid
- ✓ Solid G is sodium sulphite

233/3

CHEMISTRY

Paper 3

(PRACTICAL)

1. You are provided with:

- A monobasic acid HA, solution J.
- Sodium carbonate solution, solution Q, containing 1.325g in 250cm³ of solution.
- Solution R, containing 15.75g of M(OH).8H₂O per litre.
- Screened methyl orange indicator.

You are required to:

- Standardize solution J.
- Determine the relative atomic mass of element M in M (OH)₂. 8H₂O.

Procedure 1

Fill the burette with solution J. Pipette 25cm³ of solution Q into a clean 250ml conical flask and add 2 – 3 drops of screened methyl orange indicator. Titrate this solution with the solution in the burette and record your results in table 1 below. Repeat this procedure and complete the table. **Retain solution J in the burette for use in procedure II.**

Table 1

Titre	I	II	III
Final burette reading (cm ³)			
Initial burette reading(cm ³)			
Volume of J used (cm ³)			

(4 marks)

- a) Calculate the average volume of solution J used. (1 mark)
- b) Determine the concentration of solution Q in moles per litre (Na=23, C=12, O=16) (1 mark)
- c) (i) Determine the number of moles of the monobasic acid solution, HA, that are in the averaged value calculated in (b) above. (1 mark)
- (ii) Determine the concentration of solution J in moles per litre. (1 mark)

Procedure 2

- Using a 25cm³ measuring cylinder, transfer 25cm³ of solution R into a clean 250ml conical flask. Using a 100ml measuring cylinder, transfer 75cm³ of solution Q into the flask with solution R. Boil the mixture for about 5 minutes. After cooling filter into a conical flask and transfer the filtrate into a clean 100ml measuring cylinder and add distilled water to make exactly 100cm³ of solution. Label this solution as solution S.
- Pipette 25cm³ of solution S into a conical flask and titrate it with solution J using 2 drops of screened methyl orange indicator. Record your results in table 2 below. Repeat this to complete the table.

Table 2

Titre	I	II	III
Final burette reading (cm ³)			
Initial burette reading (cm ³)			
Volume of J used (cm ³)			

- d) Calculate the average volume of solution J used. (4 marks)
- e) Determine the number of moles of: (1 mark)
- The monobasic acid, HA, in the average volume. (1 mark)
 - Sodium carbonate in 25cm³ of solution S. (1 mark)
 - Sodium carbonate in 75cm³ of solution S. (1 mark)
 - Sodium carbonate in the original 75cm³ of solution S. (1 mark)
 - Sodium carbonate that reacted with solution R. (1 mark)
 - M(OH)₂·8H₂O in 25cm³ of solution R. (1 mark)
- (1 mole of M(OH)₂·8H₂O reacts with one mole of sodium carbonate)
- f) Determine
- the concentration of solution R in moles per litre. (1 mark)
 - the relative formula mass of M(OH)₂·8H₂O. (1 mark)
 - the relative atomic mass of M (O=16.0, H=1.0) (1 mark)

2. You are provided with:
Solid P, 2.0 g of a dibasic acid H₂X.
You are required to determine the molar heat of solution of solid P.

PROCEDURE

Place 30cm³ of distilled water into a 100ml beaker. Measure the initial temperature of the water and record it in the table below. Add all the solid P at once and stir the mixture carefully with the thermometer until all the solid dissolves. Measure the final temperature reached and record it in table.

Final temperature (°C)

Initial temperature (°C)

- Determine the change in temperature, ΔT. (3 marks)
 - Calculate the: (1 mark)
 - heat change when H₂X dissolves in water. (Assume the heat capacity of the solution is 4.2 Jg⁻¹°C⁻¹ and density is 1g/cm³) (2 marks)
 - Number of moles of the acid that were used. (Relative formula mass of H₂X is 126) (1 mark)
 - Molar heat of solution, ΔH, of the acid H₂X. (1 mark)
3. You are provided with solid G. Place all solid G in a boiling tube. Add distilled water and shake. Divide the resulting solution into three portions.

Inferences

(½ mk)

Observations

(½ mk)

CHEMISTRY PAPER 1,2 & 3

i) To the first portion add drops of 2M sodium hydroxide.

Inferences	Observations
(½ mk)	(½ mk)

ii) To the second portion dip a metallic spatula in the solution and burn it directly on a non-luminous flame.

Inferences	Observations
(½ mk)	(½ mk)

iii) To the third portion add three drops of barium nitrate solution followed by 2cm³ of 2M hydrochloric acid.

Inferences	Observations
(½ mk)	(½ mk)

iv) To the fourth portion add three drops of acidified potassium dichromate (VI) solution.

Inferences	Observations
(½ mk)	(½ mk)

b) You are provided with solid **F**. Carry out the tests below and record your observations and inferences in the spaces provided

(i) Using a metallic spatula, heat half of solid **F** in a non-luminous bunsen burner flame .

Inferences	Observations
(½ mk)	(½ mk)

(ii) Put a half spatula endful of solid **F** into a boiling tube. Add about 10cm³ of distilled water and shake.

Inferences	Observations
(½ mk)	(½ mk)

Divide the resulting solution from a(ii) above into two portions

(iii) To the first portion, 2-3 drops of universal indicator and determine its pH.

Inferences	Observations
(½ mk)	(½ mk)

(iv) To the second portion, add two drop of acidified potassium Manganate (VII) solution and shake.

Inferences	Observations
(½ mk)	(½ mk)

CHEMISTRY PAPER 1,2 & 3

(c) Put half spatula endful of solid **F** into a boiling tube and add 5 drops of ethanol followed by 2 drops of concentrated sulphuric (VI) acid. warm the mixture.

Inferences

(½ mk)

Observations

(½ mk)

for more free exam papers visit www.freekcsepastpapers.com

1. Name the process which takes place when:-

- (i) Iodine changes directly from gas to solid. (1mk)
 (ii) $\text{Fe}^{2+}(\text{aq})$ changes to $\text{Fe}^{3+}(\text{aq})$ (1mk)
 (iii) White sugar changes to black solid when mixed with excess concentrated sulphuric (IV) acid. (1mk)
2. The apparatus below was set up for the reaction of catalytic oxidation of ammonia. Study it and answer the questions that follow.

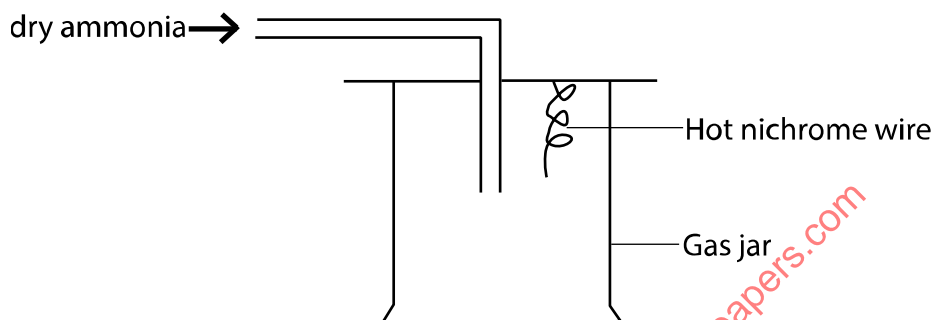

- (i) Write an equation for the reaction that take place in the gas jar. (1mk)
 (ii) What is the role of hot nichrome wire. (1mk)
 (iii) Write the formula of the complex ion formed when excess ammonia gas is passed through a solution containing Zn^{2+} ions. (1mk)
3. 9.12g of a gaseous compound contains 8g of silicon while the rest is hydrogen. Determine empirical formula of the compound. (Si = 28, H = 1) (3mks)
4. The set-up below was used to study some properties of air.

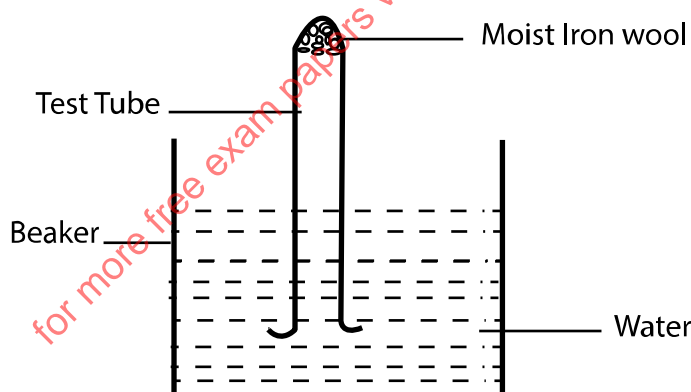

- a) Draw a well labeled diagram showing the observation made after five days. (3mks)
5. 16g of ethanol ($\text{C}_2\text{H}_5\text{OH}$) were completely burnt in air. The heat evolved caused the temperature of 600cm^3 of water to change from 20°C to 85°C . Calculate the molar enthalpy of combustion of ethanol. (H = 1, C = 12, O = 16, S.H.C = 4.2Kj/Kg/k) (3mks)
6. Calculate the volume of oxygen produced when 10g of silver nitrate was completely decomposed by heating at s.t.p. (Ag = 108, N = 14, O = 16, M.G.V. at s.t.p = 22.4dm^3) (3mks)
7. A radioactive substance underwent decay as shown below.

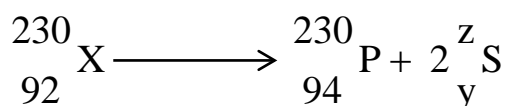

- (i) Identify particle S (1mk)
 (ii) List two properties of particle S (2mks)

8. a) What is fractional crystallization?

(1mk)

b) The table below gives the solubility of X and Y at 0°C and at 45°C.

Salt	Solubility in g/100g of water	
	0°C	45°C
X	53	73
Y	10	11

A solution containing 57g of X and 8g of Y in 100g of water at 70°C was cooled to 0°C. Some crystals were observed.

- Identify the crystals formed. (1mk)
- Calculate the mass of the crystals formed. (1mk)

9. Complete the table below.

Metal	Aluminium	Lead	Sodium
Chief Ore	Bauxite	i) _____	Rock Salt
Chemical formula	ii) _____	iii) _____	iv) _____
Method of extraction	v) _____	Reduction	vi) _____

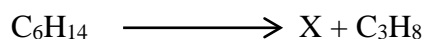
10. The molecular formula of a hydrocarbon is C₆H₁₄. It can be converted into two smaller hydrocarbons as shown below.

- Name the process through which C₆H₁₄ is converted to X and C₃H₈. (1mk)
 - Name X and draw the structural formula. (1mk)
 - Write the chemical equation for the complete combustion of C₃H₈. (1mk)
11. Use the information below to answer the equations that follow.

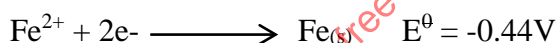
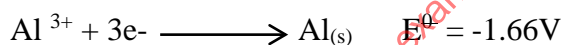

- Calculate the e.m.f. of the cell formed by combining the two half cells. (1mk)
- Why is it not advisable to keep a solution of iron (II) nitrate in a container made of Aluminium? (2mks)

12. Study the diagram below which shows energy level diagram.

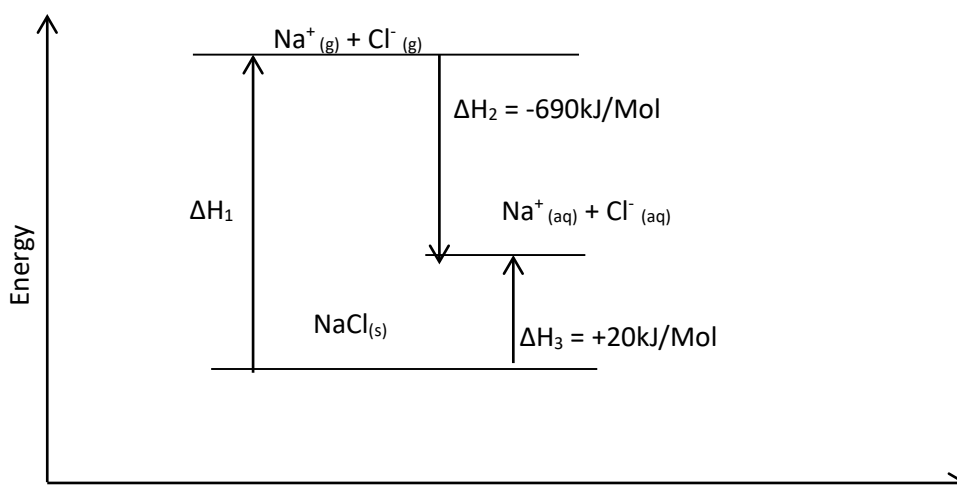

Reaction path

(i) Name enthalpy (2mks)

$$\Delta H_1$$

$$\Delta H_2$$

(ii) Calculate the ΔH_1 from the energy level diagram. (1mk)

13. Starting with copper powder describe how pure copper (II) carbonate can be prepared. (3mks)

14. The graph below is a plot of concentration against time for a given reaction.

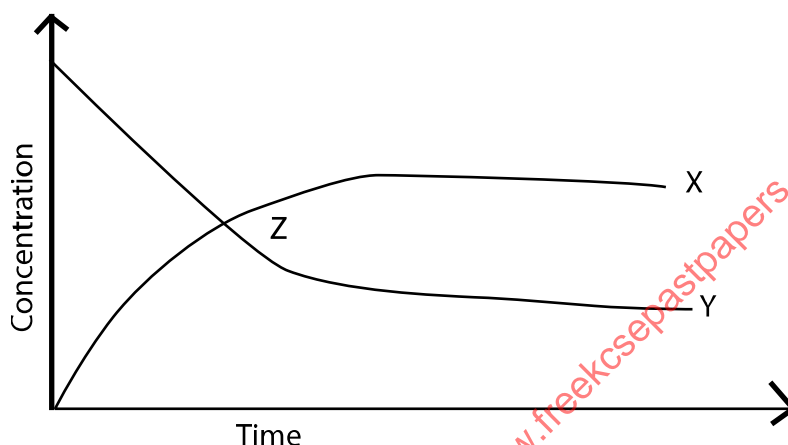

a) What is represented by curve X? Explain. (1mk)

b) Explain why curve Y drops fast initially. (1mk)

c) What does point Z represent on the curve? (1mk)

15. The table below gives some of properties of the three elements in Group (VII) in the periodic table. The letters do not represent the actual symbols of elements. Study it and answer the questions that follow.

Element	Melting point $^{\circ}\text{C}$	Boiling point $^{\circ}\text{C}$
W	-101	-34.7
P	-7	58.8
S	114	184

a. Which element is a gas at room temperature? Give a reason. (1mk)

b. Explain why the boiling point of P is higher than that of W? (1mk)

c. In which chemical family do W, P, S belong to? (1mk)

16. (a) State the product of electrolysis of molten copper (II) chloride at the cathode. (1mk)

b) Explain why the solid copper (II) chloride does not conduct electric current but does it in molten form. (1mk)

c) Explain why mercury is not an electrolyte? (1mk)

17. Describe how to prepare crystals of potassium sulphate starting with 50cm^3 of 1M potassium hydroxide. (3mks)

18. In an experiment dry hydrogen gas was passed over heated lead (II) oxide as shown in the diagram below.

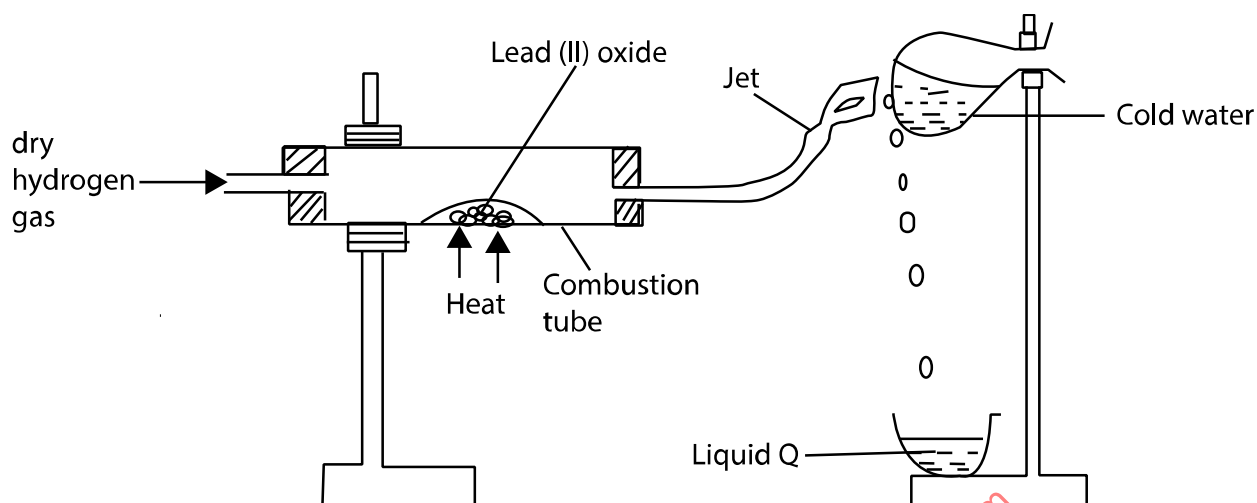

- Name liquid Q (1mk)
 - State the observation made at the jet. (1mk)
 - Write an equation for the reaction that takes place in the combustion tube. (1mk)
19. State **two** differences between non-luminous and luminous flames. (2mks)

Non-luminous

Luminous

i)

i)

ii)

ii)

20. Study the scheme below and answer the questions that follow.

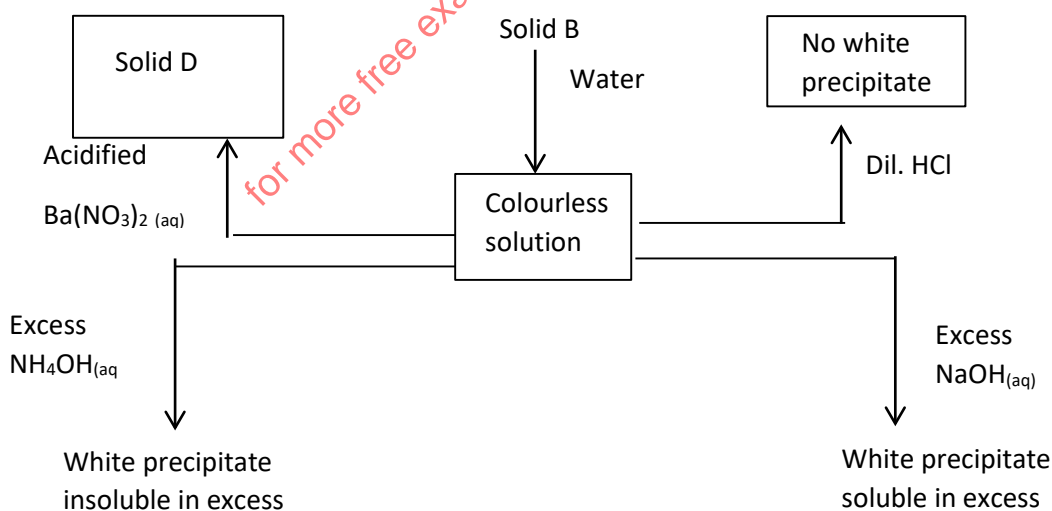

CHEMISTRY PAPER 1,2 & 3

a) Identify solution M and solid D.

i. Solution M

(1mk)

ii. Solid D

(1mk)

b) Write an ionic equation for the reaction between solution M and excess of ammonia $\text{NH}_4\text{OH}_{(\text{aq})}$

(1mk)

21. Carbon (II) oxide gas can be prepared in the laboratory by the process shown below.

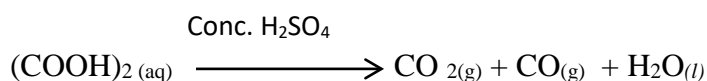

a) State the function of con. H_2SO_4 in the equation above.

(1mk)

b) How would you remove carbon (IV) oxide from the mixture of carbon (IV) oxide and carbon (II) oxide.

(1mk)

c) State one industrial use of carbon (II) oxide.

(1mk)

22. State observation made when sulphur (IV) oxide is bubbled through.

a. Acidified potassium manganate (VII) solution.

(1mk)

b. Acidified potassium chromate (VI) solution.

(1mk)

c. Which property of sulphur (IV) oxide is demonstrated by (a) and (b) above.

(1mk)

23. Study the information in the table below and answer the questions that follow.

Hydrocarbon	Number of carbon atoms	Relative molecular mass of the hydrocarbon
A	2	28
B	3	42
C	4	56

i. What is a hydrocarbon?

(1mk)

ii. Predict the relative molecular mass of the hydrocarbon with 5 carbon atoms and draw its structural formula.

RMM = _____

(1mk)

Structural formula

(1mk)

24. Define the following terms

a) Isomerism

(1mk)

b) Vulcanisation

(1mk)

25. The diagram below shows a chromatogram obtained when flower extracts of a given plant were subjected to chromatography.

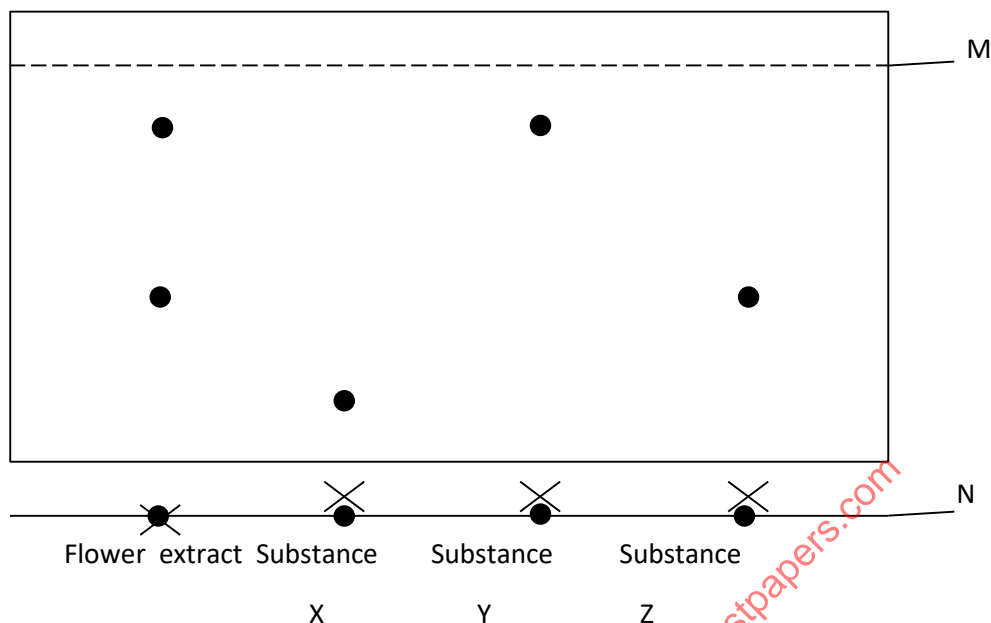

a) Name the parts labeled

M _____ (1mk)

N _____ (1mk)

b) Which substances make up the flower extract? (1mk)

26. Use the information in the table below to answer the questions that follow. The letters do not represent the actual symbols of the elements.

Element	I	II	III	IV	V
Atomic number	18	5	3	5	20
Mass number	40	10	7	11	40

a) Which two elements represent isotopes?

Give a reason. (2mks)

b) Calculate the number of neutrons in an atom of element I. (1mk)

27. a) State the Charles's law. (1mk)

b) The volume of a sample of hydrogen gas at a temperature of 18°C and 2.0×10^5 pascals was $4.5 \times 10^{-2} \text{M}^3$. Calculate the temperature at which the volume of the gas would be $2.8 \times 10^{-2} \text{M}^3$ at 2.0×10^5 pascals. (2mks)

28. What is an atom? (1mk)

CHEMISTRY PAPER 1,2 & 3
KIRINYAGA WEST
 233/2
CHEMISTRY (THEORY)
PAPER 2

1. a) The grid below shows part of the periodic table. Use it to answer the questions that follow. The letters do not represent actual symbols.

C											G
	D			E	F					K	
	H	J								L	M

- ii) Select the most reactive non-metal. Explain. (2mks)
 iii) Identify an element that does not form compounds. (1mk)
 iv) Write the formula of the nitride of D. (1mk)
 v) Identify the element that forms giant covalent structure. (1mk)
 vi) How does the reactivity of C with chlorine compare with of H with chlorine? Explain. (2mks)
 b) 1.08g of element E were heated in a stream of excess chlorine gas.
 i) Write a balanced equation of the reaction. (1mk)
 ii) Calculate the maximum mass of the product formed. (E = 27, Cl = 35.5) (2mks)
 c) Using dots (•) and crosses (X) to represent electrons, draw a diagram to show the bonding in compound formed when K reacts with J. (1mk)
 d) State and explain the observation made when sodium carbonate powder is added to aqueous solution of Iron (III) chloride in a test tube. (2mks)
 2. a) The set up below was used to investigate some properties of hydrogen,

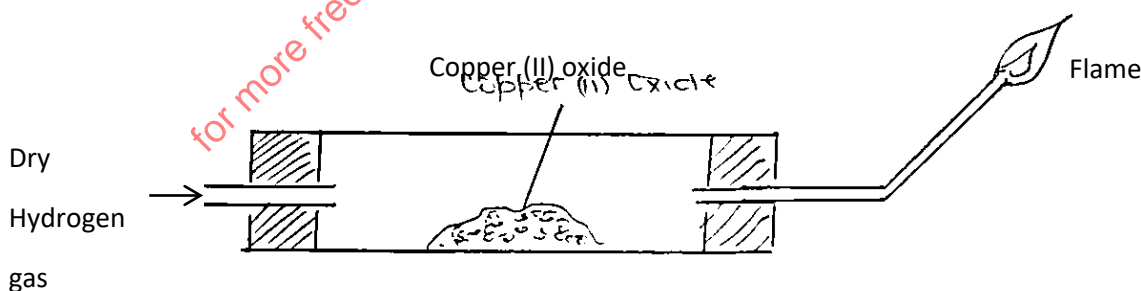

- i) What condition is missing in the set up for the reaction to occur? (1/2mk)
 ii) Hydrogen gas is allowed to pass through the tube for some time before it is lit. Explain. (2mks)
 iii) Write an equation for the reaction that occurs in the combustion tube. (1mk)
 iv) When the reaction is complete, hydrogen gas is passed through the apparatus until they cool. Explain. (1mk)
 v) What property of hydrogen is being investigated? (1/2mk)
 vi) What observation confirms the property in (v) above. (1mk)

b) i) State one way in which nuclear reactions differ from ordinary chemical reactions. (1mk)

ii) The following is part of Uranium decay series

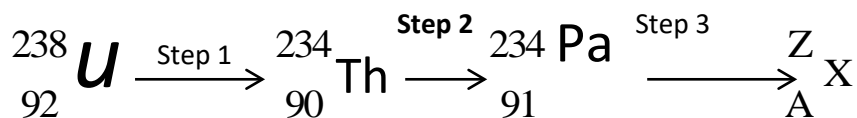

i) Which particles are emitted in Step 1 and 2? (2mks)

ii) If a beta particles is emitted in Step 3, find the value of Z and A. (1mk)

iii) If the activity of Thorium – 234 is reduced to 12.5% in 48 hours, find its half-life. (2mks)

3. Study the given reduction potentials and answer the questions that follow. The letter do not represent the actual symbols of elements.

	$E^\ominus(\text{V})$
$\text{X}^{2+}(\text{aq}) + 2\text{e}^- \longrightarrow \text{X}(\text{s})$	-2.90
$\text{Y}^{2+}(\text{aq}) + 2\text{e}^- \longrightarrow \text{Y}(\text{s})$	-2.38
$\text{Z}^{2+}(\text{aq}) + 2\text{e}^- \longrightarrow \text{Z}(\text{s})$	0.00
$\frac{1}{2}\text{A}_2(\text{g}) + \text{e}^- \longrightarrow \text{A}(\text{aq})$	+2.87

- Which element is likely to be hydrogen. (1mk)
 - Draw an electrochemical cell formed when Y and A are combined. Show the direction of flow of electrons. (2mks)
 - Calculate the e.m.f. of the electrochemical cell in (ii) above. (2mks)
- b) The set up below was used during the electrolysis of a solution of Magnesium sulphate using inert electrodes.

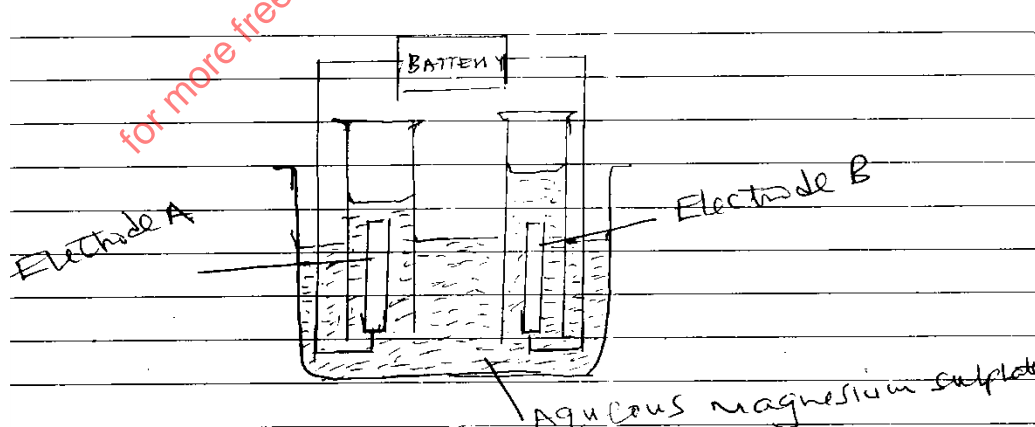

- Identify the ions present in the electrolyte. (1mk)
- Write half equation for the reactions taking place at
 - Cathode (1mk)
 - Anode (1mk)
 - Which electrode is the cathode? Explain. (2mks)
- Calculate the quantity of electricity that would liberate 1.2dm^3 of oxygen gas at r.t.p.

4. a) The set up below can be used to prepare ethyne gas.

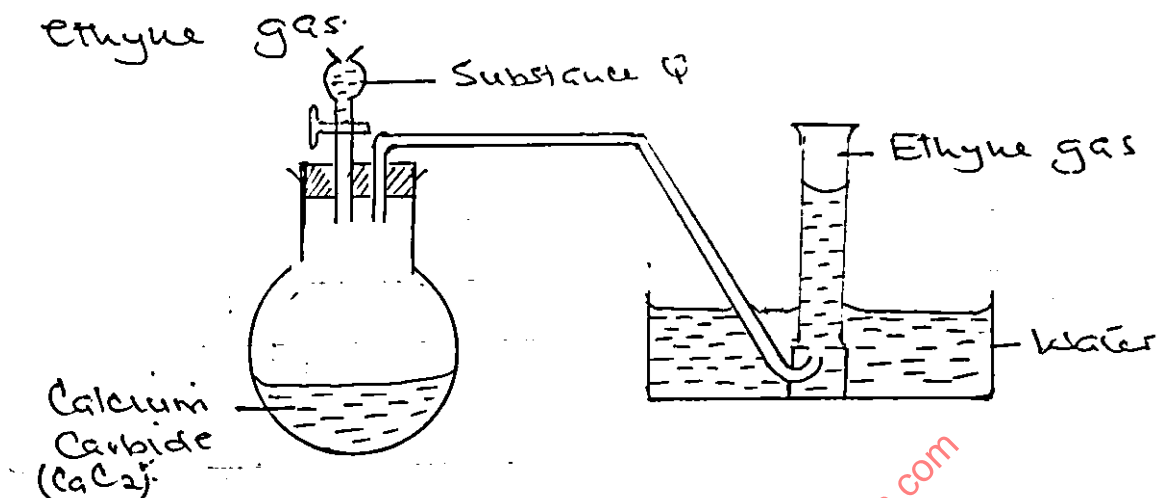

- (i) Identify substance Q (1mk)
- (ii) Write the equation for the reaction for the production of ethyne gas. (1mk)
- (iii) In an experiment, 100cm³ of ethyne gas was mixed with 60cm³ of oxygen gas and the mixture ignited. Determine the total volume of the gaseous mixture at the end of experiment under standard conditions. (2mks)

b) Give the systematic names of the following compounds.

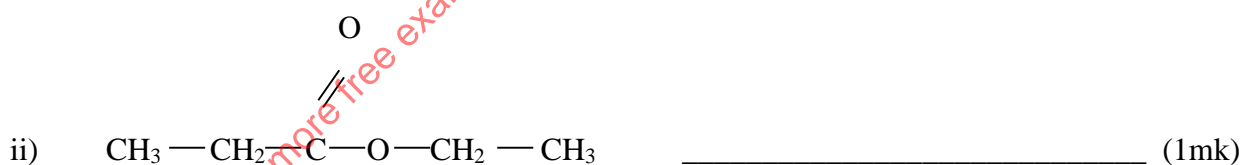
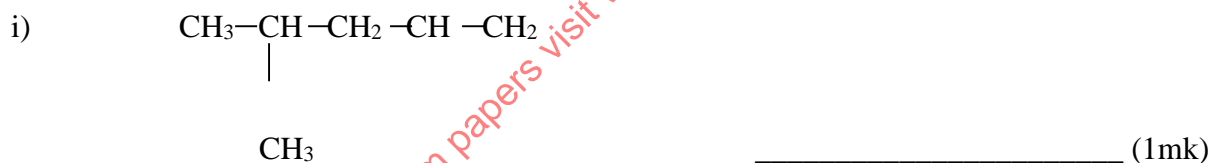

c) Study the scheme below and answer the questions that follow.

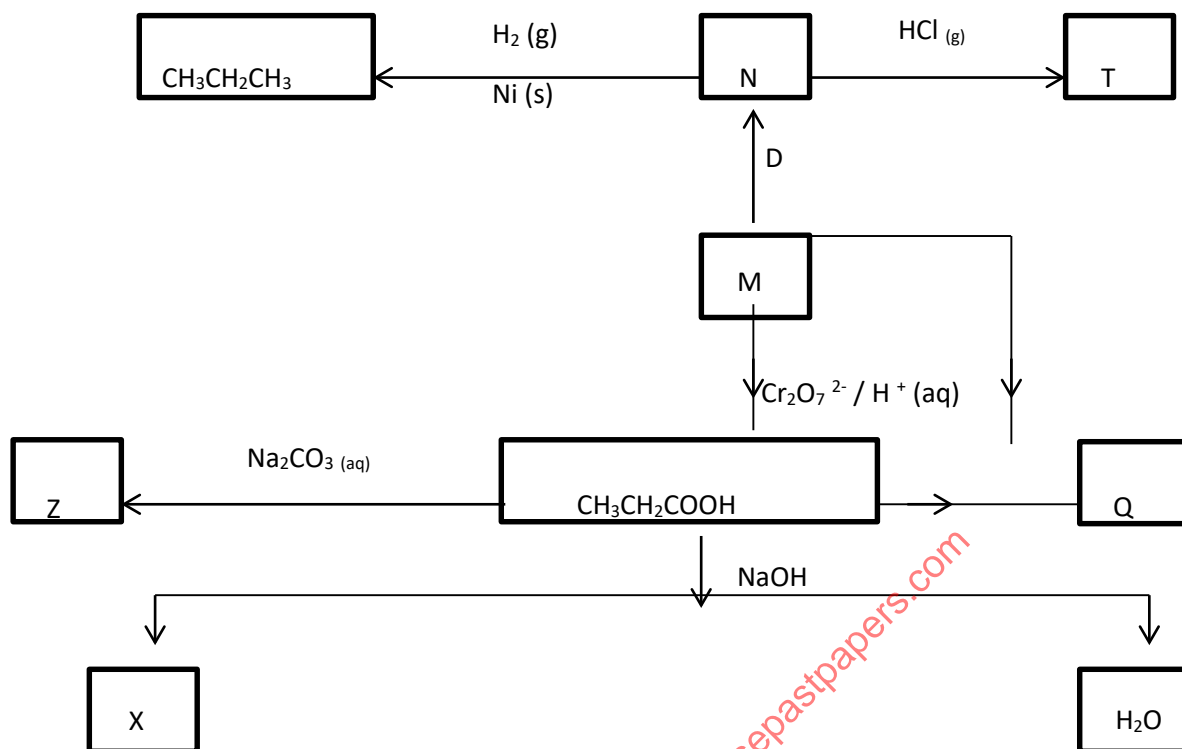

- i) Name the substances (2mk)
 - ii) Write the equation for the reaction leading to the formation of product Z. (1mk)
 - iii) Substance M reacts with propanoic acid to form substance Q. Name this type of reaction. (2mks)
 - iv) Draw the structure of the compound T and give its name. (2mks)
5. The table below gives the volume of the gas produced when different volumes of 2M hydrochloric acid were reacted with 1.0g of a lump of an alloy of magnesium and copper at room temperature.

Volume of 2M HCl (cm^3)	Volume of gas (cm^3)
0	0
10	240
20	480
30	600
40	600
50	600

- a) Write an equation for the reaction that occurred. (1mk)
- b) On the grid provided below, plot a graph of the volume of the gas produced (vertical axis) against the volume of acid added. (3mks)
- c) From the graph, determine
 - i) The volume of the gas produced if 13.0cm^3 of the 2M HCl had been used. ($1/2$ mk)
 - ii) The volume of the 2M HCl required for the reaction to go to completion. ($1/2$ mk)

CHEMISTRY PAPER 1,2 & 3

- d) State and explain the effect on the rate of production of gas if
- 1.0g of the lump of the alloy was replaced by 1.0g powder of the alloy. (1½mks)
 - the reaction was carried out at 35°C. (1½mks)
- e) Calculate the percentage of copper in the alloy. (3mks)
- (Mg = 24, Molar gas volume at r.t.p = 24000cm³)

6. The flow chart below shows the industrial manufacture of sulphuric (VI) acid. Study it and answer the questions that follow.

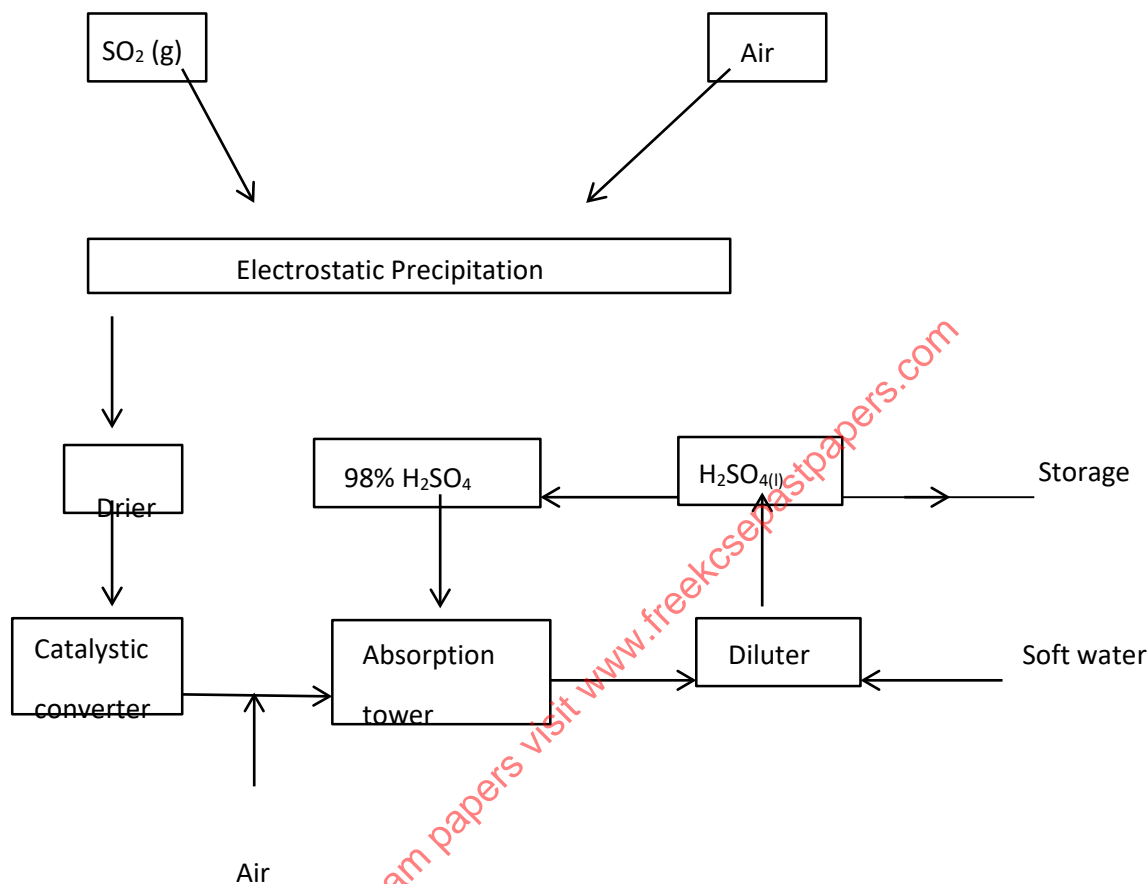

- Using an equation state one source of sulphur (IV) oxide. (1mk)
 - Name one substance removed by electrostatic precipitation. (1mk)
 - Name a suitable substance that can be used in the drier. (1mk)
 - In the catalytic converter, the temperature is adjusted to about 450°C without external heating. Explain. (1mk)
 - Write an equation of the process taking place in the absorption tower. (1mk)
 - Explain why it is not advisable to use hard water in the diluter. (1mk)
- Sulphuric acid reacts both as an acid and an oxidizing agent. Using zinc metal illustrate these properties. (2mks)
- Concentrated sulphuric acid is used to prepare the other two mineral acids i.e. nitric acid and hydrochloric acid. What property of the acid makes it possible? (1mk)
- The reaction shown below occurs in the catalytic converter.

$$2\text{SO}_2(\text{g}) + \text{O}_2(\text{g}) \rightleftharpoons 2\text{SO}_3(\text{g}); \Delta H = -\text{ve.}$$
 State two ways that could be used to increase the yield of SO₃(g) (1mk)

7. The flow chart below shows some reactions starting with lead (II) nitrate. Study it and answer the questions that follow.

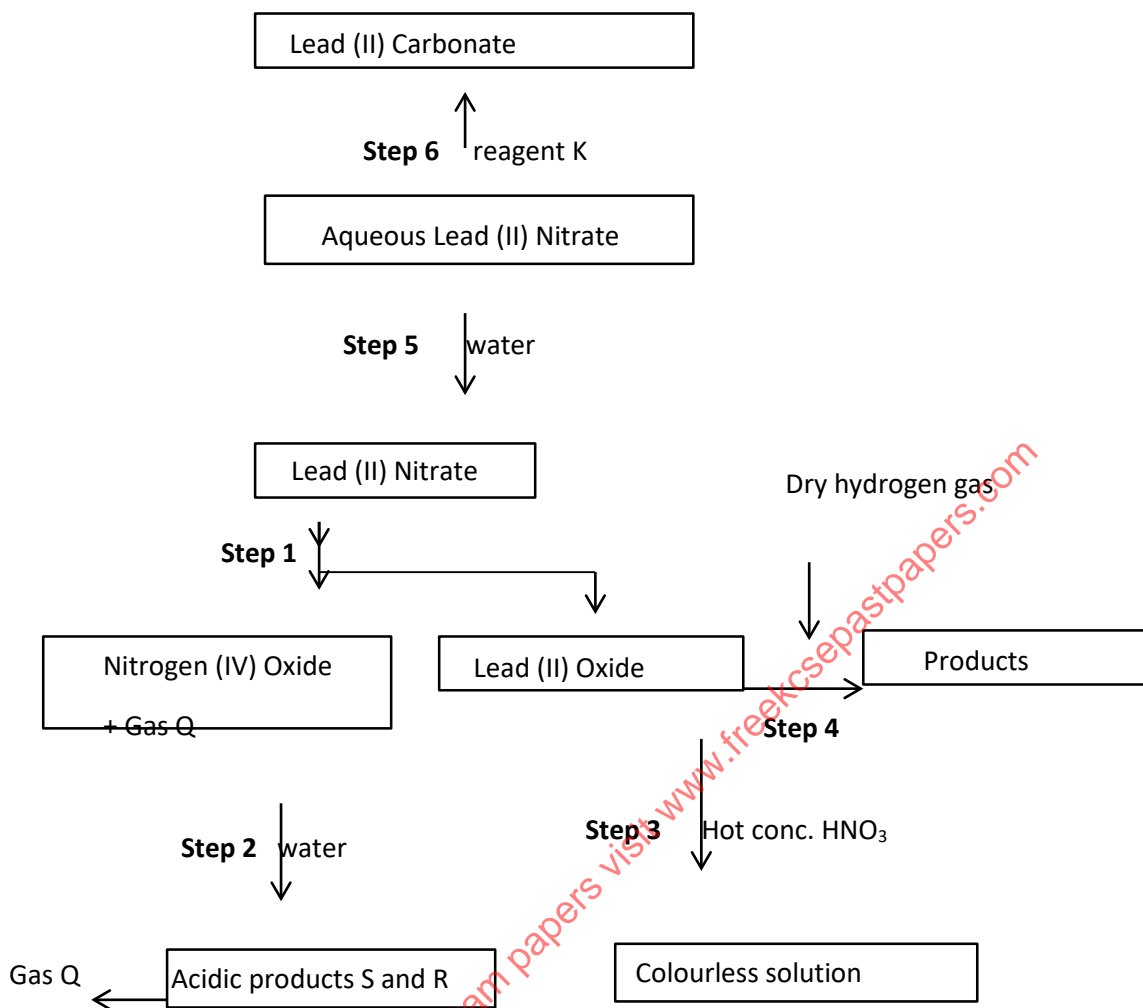

- a) i) State the conditions necessary in Step 4 (1mk)
 ii) Identify (1/2mk)
 a) Reagent K (1/2mk)
 b) Gas Q (1/2mk)
 c) Acidic products S and R. (1mk)
 iii) Write (1mk)
 a) The ionic equation for the reaction in step 6. (1mk)
 b) The equation for the reaction in Step 4. (1mk)
- b) The use of materials made by Lead in roofing and water pipes is being discharged. State (2mks)
 i. Two reasons why these materials have been used in the past. (2mks)
 ii. One reason why their use is discouraged. (1mk)
- c) The reaction between Lead (II) Nitrate and sulphuric acid starts and stops immediately. Explain. (2mks)

CONFIDENTIAL INSTRUCTIONS TO SCHOOLS

233/3

CHEMISTRY

PAPER 3

In addition to the fittings and apparatus found in a Chemistry laboratory, each candidate will require the following:

1. 100 cm³ of solution J
2. 100 cm³ of solution P
3. 50 ml burette
4. 25 ml pipette
5. A white tile
6. 250ml conical flask
7. Solid **Q**
8. 1 boiling tube
9. 5 test tubes in a rack
10. Solid **H**
11. Metallic spatula
12. Solid sodium hydrogen carbonate in a stoppered container (0.1g)
13. A blue and red litmus paper
14. 10ml measuring cylinder
15. Test tube holder

Access to:

1. Methyl Orange indicator
2. Bunsen burner
3. 0.5M sodium chloride with a dropper
4. Distilled water in a wash bottle
5. Universal indicator solution
6. 2M Sodium hydroxide solution with a dropper
7. 2M aqueous ammonia solution with a dropper
8. pH chart
9. 2M Nitric (V) acid with a dropper
10. Acidified Potassium manganate (VII) solution with a dropper (0.02M)
11. Acidified Potassium dichromate (VI) solution with a dropper (0.166M)
12. 2M Barium nitrate solution

Notes:

1. Solution **P** is 0.1 M anhydrous Sodium carbonate
2. Solution **J** is 0.25M Hydrochloric acid
3. Solid **Q** is hydrated Aluminium ammonium sulphate (1g)
4. Solid **H** is Maleic acid (0.5g)
5. 0.02M H⁺ /KMnO₄ is prepared by dissolving 3.2g of KMnO₄ in 400cm³ of 1M H₂SO₄ and then diluting to one litre.
6. 0.166M acidified K₂Cr₂O₇ is prepared by dissolving 4.6g of K₂Cr₂O₇ in 400cm³ of 1M H₂SO₄ and then diluting to one litre.

CHEMISTRY PAPER 1,2 & 3
KIRINYAGA WEST
233/3
CHEMISTRY
PAPER 3
PRACTICAL

1. You are provided with:
- Solution P, containing 10.6g of X_2CO_3 per litre.
 - Solution J, 0.25M hydrochloric acid.

You are required to;

- Determine the relative formula mass of P.
- Calculate the relative atomic mass of X.

Procedure

Using a pipette place 25cm^3 of solution P into a conical flask. Add three drops of methyl orange indicator. Fill the burette with solution J and titrate solution P with solution J. Record your results in the table below. Repeat the titration two more times and complete the table.

Table of results

Experiment number	I	II	III
Final burette reading (cm^3)			
Initial burette reading (cm^3)			
Volume of solution J Used (cm^3)			

(4 marks)

- Calculate;
 - The average volume of solution J used. (1 mark)
 - The number of moles of solution J used. (2marks)
- The equation for the reaction is;

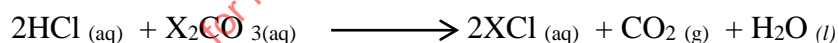

Calculate;

- The number of moles of solution P used. (2 marks)
 - Molarity of solution P, X_2CO_3 (2 marks)
 - The relative formula mass of P (2 marks)
 - Given that C = 12, O = 16 and H = 1, calculate the relative atomic mass of X in X_2CO_3 . (2marks)
2. You are provided with solid Q. Carry out the following tests. Write your observations and inferences in the spaces provided.
- Place about one half of solid Q in a dry test tube. Heat gently then strongly. Test any gases produced with blue and red litmus papers.

b)

Observations	Inferences
(2mks)	(1mk)

c) Place the remaining amount of solid Q in a boiling tube. Add about 10cm³ of distilled water and shake the mixture.

Observations	Inferences
(1mk)	(1mk)

c) Divide solution Q into four portions of 2cm³ each in separate test tubes. Use the portions for tests (i) to (iv) below.

i) To the first portion add sodium hydroxide solution dropwise until in excess.

Observations	Inferences
(1mk)	(1mk)

ii) To the second portion add about 1cm³ of sodium chloride solution.

Observations	Inferences
(1mk)	(1mk)

iii) To the third portion add aqueous ammonia dropwise until in excess.

Observations	Inferences
(1mk)	(1mk)

iv) To the fourth portion add three drops of aqueous barium nitrate followed by five drops of nitric (V) acid.

Observations	Inferences
(1mk)	(1mk)

3. You are provided with solid H. Carry out the tests below and record the observations and inferences in the spaces provided.

a) Using a clean metallic spatula heat some of solid H in a Bunsen burner flame.

Observations	Inferences
(1mk)	(1mk)

b) Put the remaining solid H in a clean boiling tube. Add about 8cm³ of distilled water and shake well.

Observations	Inferences
(1mk)	(1mk)

c) Divide the solution obtained in (b) above into four portions.

i) use the first portion to determine the pH of the solution by adding three drops of universal indicator solution.

Observations	Inferences
(1mk)	(1mk)

ii) To the second portion, add three drops of acidified potassium manganate (VII) solution.

Observations	Inferences
(1mk)	(1mk)

iii) To the third portion add two drops of acidified potassium dichromate (VI) solution.

Observations	Inferences
(1mk)	(1mk)

iv) To the fourth portion add solid sodium hydrogen carbonate.

Observations	Inferences
(1mk)	(1mk)

CEKENA

233/1

CHEMISTRY PAPER 1 THEORY

1. (i) Give two reason why laboratory apparatus are made of glass. (2 mks)
 (ii) Name the apparatus drawn below and state its use (2 mks)

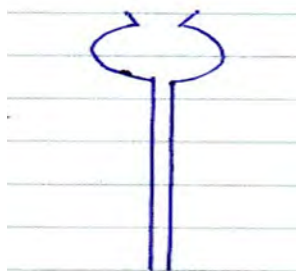

2. (i) Using dots (.) and cross (x) to represent electrons draw the electron diagram for ammonia molecule ($N = 7, H = 1$) (1 mk)
 (i) Explain the following observations:
 Oxygen and sulphur are in the same group of the periodic table. The hydride of oxygen is a liquid at room temperature while that of sulphur is gaseous at room temperature. (2 mks)
3. You are provided with the following reagents: Water, lead carbonate, dil. HNO_3 and solid sodium chloride. Describe in very clear steps how you would prepare a sample of lead II chloride (3 mks)
4. 30cm^3 of 0.06M sodium hydroxide were reacted with 25cm^3 of dibasic acid $HOOC(CH_2)_xCOOH$, containing 4g/l . Calculate the value of x (3 mks)
5. (i) Nitric (V) acid prepared in the laboratory is yellow in colour. What causes the yellow colour (1 mk)
 (ii) State any 2 observations that would be made when concentrated HNO_3 is added to copper turnings (2 mks)
6. Phosphorous is in group (V) of the periodic table. Explain the following observations.
 (i) Phosphorous exhibit two M.P (1 mk)
 (ii) Chloride of phosphorous form misty fumes in damp air (2 mks)

CHEMISTRY PAPER 1,2 & 3

7. Steam was passed over iron in a combustion tube as shown below.

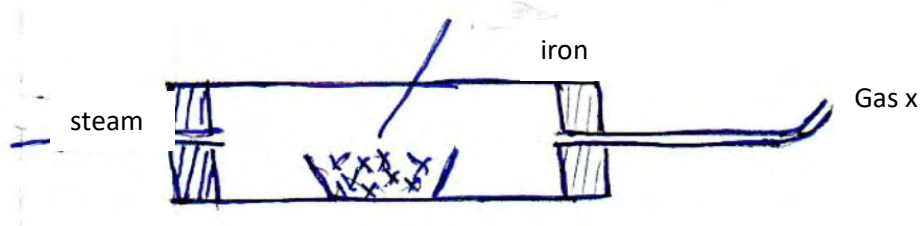

- (i) What must be included in the diagram for iron to react (1 mk)
- (ii) Name Gas x (1 mk)
- (iii) State and explain the precautions to be observed when carrying out the above experiment (2 mks)

for more free exam papers visit www.freekcsepastpapers.com

8. A gas of chlorine gas and air were inverted over a trough of sodium hydroxide as shown below.

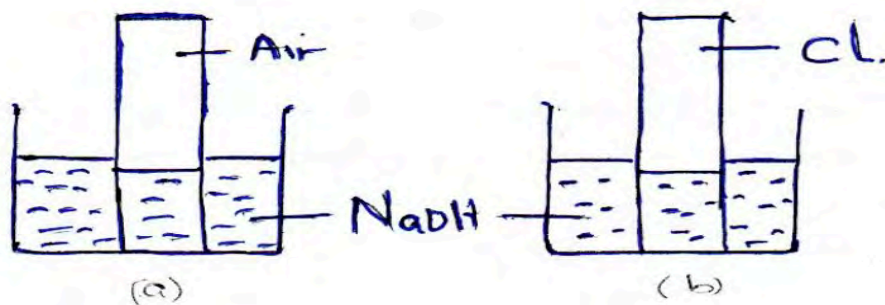

- (i) In which case was there a larger change in volume in the gas jar. Explain (2 mks)
 - (ii) State any one important use of chlorine (1 mk)
9. An organic compound contains carbon and hydrogen only. When this compound was burnt in excess air it gave 9.6g of CO₂ and 4.9g of H₂O. The molecular mass of the hydrocarbon is 58. Determine the molecular formula. (C = 12, H = 1) (3 mks)
10. (a) Name one gas used together with oxygen in welding other than acetylene gas. (1 mk)
- (b) State two other uses of the gas named above (2 mks)
11. Study the experiment below and answer the questions that follow. The gas produced ignites spontaneously.

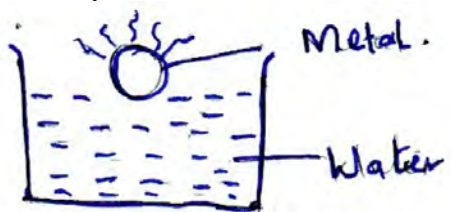

- (i) Identify the metal used above (1 mk)
 - (ii) Which gas is produced (1 mk)
 - (iii) What will be the colour of phenolphthalein indicator in the resulting solution (1 mk)
12. The following diagram represents a charcoal burner. Study it and answer the following questions.

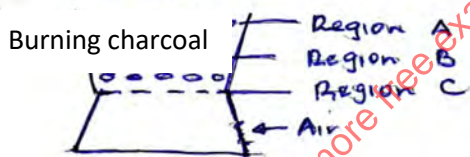

Write the equation taking place at the regions

- A (1 mk)
 - B (1 mk)
 - C (1 mk)
13. State what would be observed if concentrated sulphuric (VI) acid is added to
- (a) Sugar crystals (1 mk)
 - (b) Hydrated copper II sulphate crystals (1 mk)
 - (c) State the characteristics of the acid being tested above in (a) and (b) (1 mk)
14. When an electric current was passed through molten substances U and N in different containers the following observations were made:
- | | |
|----------|---|
| Molten M | Conduct electricity and is not decomposed |
| Molten N | Conduct electricity and a gas is formed at the electrodes |

Suggest the type of bonding present in

CHEMISTRY PAPER 1,2 & 3

- (a) Substance M (1 mk)
 (b) Substance N (1 mk)
15. A given sample of ink is a mixture of red dye, blue dye and orange dye. The blue dye is least absorbed than the rest and the red dye is most sticky. (1½ mks)

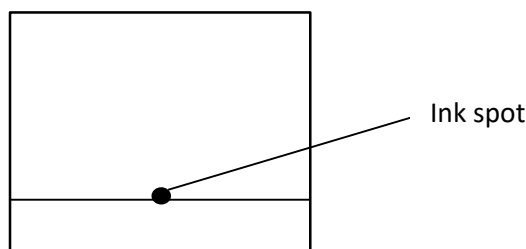

- (b) The above dyes are soluble in water. Describe how pure sample of blue dye can be obtained (1 mk)
- (c) Name the solvent used in paper chromatography (½ mk)
16. An element X form an ion with formula X^+ . The electronic configuration of X is 2.8.
 (i) To which family of elements does element X belong? Explain. (2 mks)
 (ii) Write an equation for the reaction of element X and water. (1 mk)
17. Element W has two isotopes W – 36 and W – 40 which occur in the ratio X:4. Given that R.A.M of W is 37.25, find the value of X (3 mks)
18. Describe an experiment that can be used to determine whether a given sample of a liquid is pure. (2 mks)
19. Below is a set up apparatus used to react ammonia gas with iron (II) chloride

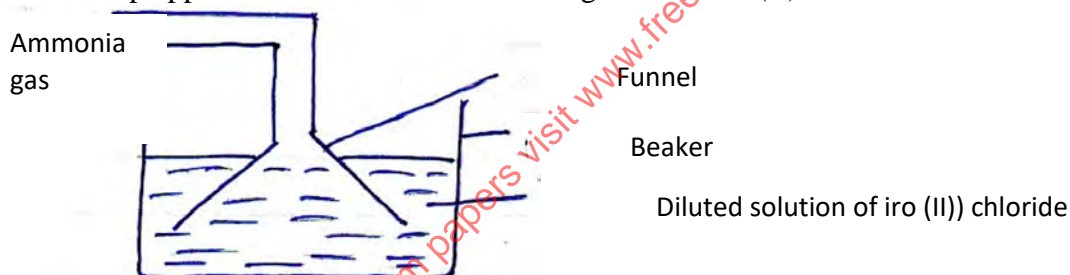

- (a) State observation made in the beaker (1 mk)
 (b) Write ionic equation for the reaction taking place (1 mk)
 (c) Give a reason for using a funnel to deliver the ammonia into beaker (1 mk)
20. An hydrocarbon can be represented as C_2H_2
 (a) Name the hydrocarbon (1 mk)
 (b) State two reagents that can be used to generate the hydrocarbon (1 mk)
 (c) Identify the group of hydrocarbon into which C_2H_2 belongs to (1 mk)

21. Study the diagram below and answer the questions that follow.

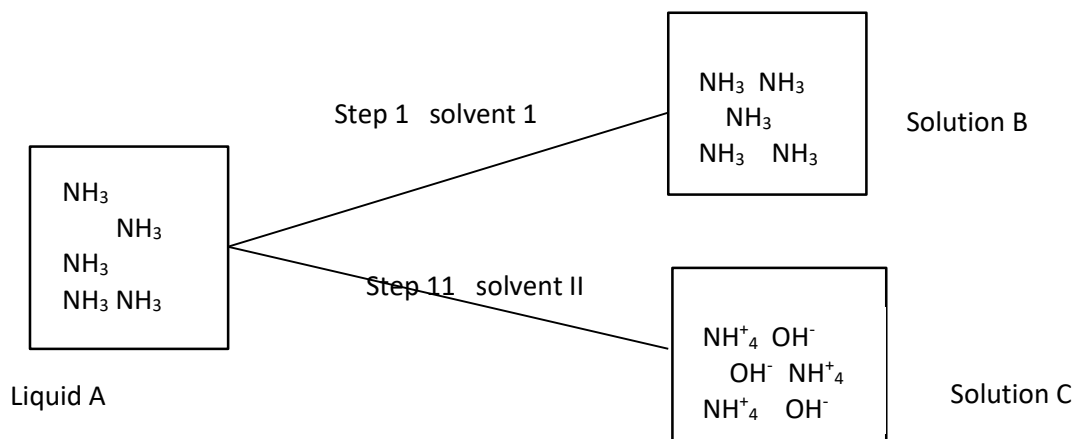

- (a) Identify the solvent used in step I and step II (2 mks)
- (b) State and explain what is observed if a red litmus paper was dipped in solution B and C (2 mks)
22. The table below shows solutions and their PH value
- | Solution | P | R | Z |
|----------|-----|-----|------|
| PH value | 2.0 | 7.0 | 14.0 |
- (a) Select two solutions that would react with Zinc hydroxide. Explain (1½ mks)
- (b) Write an ionic equation for the reaction between Copper (II) ions in a solution and excess ammonia solution (1 mk)
- (c) Name the complex ion formed in the reaction in (b) above (½ mk)
23. The apparatus below was set for the preparation of oxygen gas in the laboratory.

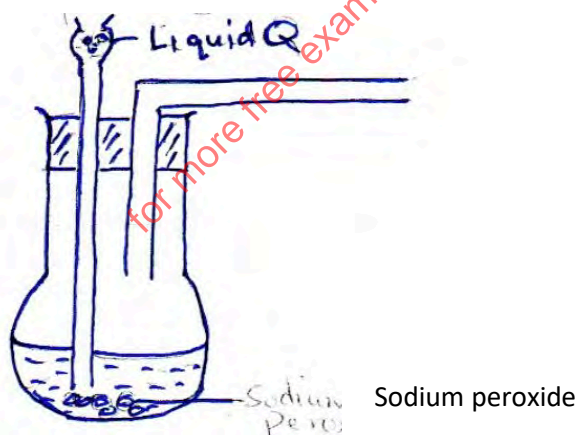

- (a) Complete the diagram to show how oxygen gas is collected. (1 mk)
- (b) Name liquid Q (1 mk)
- (c) Write balanced chemical equation for the reaction that takes place in the flask (1 mk)
- (d) Give a reason why it is preferred to use warm water to cold water when collected oxygen gas. (1 mk)

24. Study the information in the table below and answer the questions below

Bond	C – H	Cl – Cl	C - Cl	H – Cl
Bond energy K/mole	414	244	326	431

Calculate the enthalpy change of the reaction

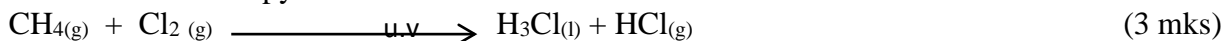

25. (a) State Graham's law (1 mk)
 (b) 48cm^3 of an oxide of nitrogen diffused through a porous plug in the same time, it took 159cm^3 of helium to diffuse through the same plug under the same conditions. What is the molecular mass of the oxide of nitrogen? (3 mk)
26. Draw in the space provided a labeled diagram of the set-up of the apparatus that can be used to electrolyse molten lead (II) iodide. (3 mk)
27. Explain why molten sodium chloride conducts electricity, but solid sodium chloride does not. (2 mks)

CEKENA
CHEMISTRY
233/2
FORM IV

Q1. The grid below shows a part of the periodic table. The letters do not represent the actual symbols. Study it and answer the questions that follow.

C							T
					U		
X	K		M		Q	W	
	Y				P		Z
J							

- a) Identify the elements in period 1 (1mk)
 b) With a reason, identify the element with the largest atomic radius (2mks)
 c) Draw the atomic structure of element (1mk)
 d) Write down the electronic configuration of elements Y and W (2mks)
 e) Element G forms an ion G^{3-} and its ionic configuration 2:8:8. Indicate its position on the grid above (1mk)

CHEMISTRY PAPER 1,2 & 3

- f) Identify an element whose oxide reacts with both acids and alkalis 1mk
- g) i. Write down the chemical formula of the compound formed between elements K and W. 1mk
- ii. Draw the bonding in the compound formed in g (i) above using dot (.) and crosses (x) to represent electrons. 1mk
- h) Compare the atomic radius of elements X and K. Explain. 2mks
- Q2. a) Draw and name two isomers of pentane. 2mks

b) Study the flow of diagram below and then answer the questions that follow

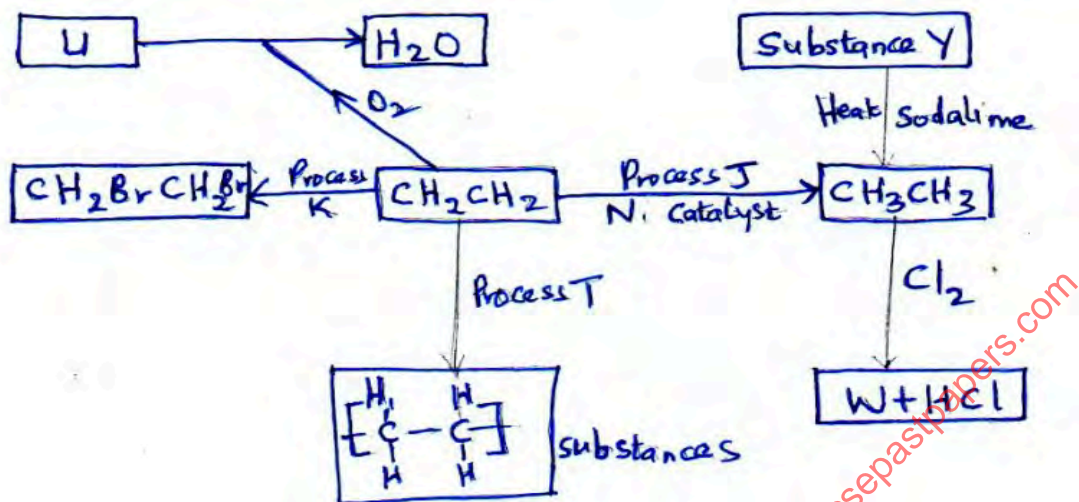

- i) Name process 3mks
- ii) State the reagents necessary for process J and K 1mk
- iii) Name substance 4mks
- b) Describe how burning can distinguish CH_2CH_2 from CH_3CH_3 2 mks

Q3. The apparatus below were arranged in an attempt to prepare carbon (II) oxide gas. Study the diagram and answer the questions that follow.

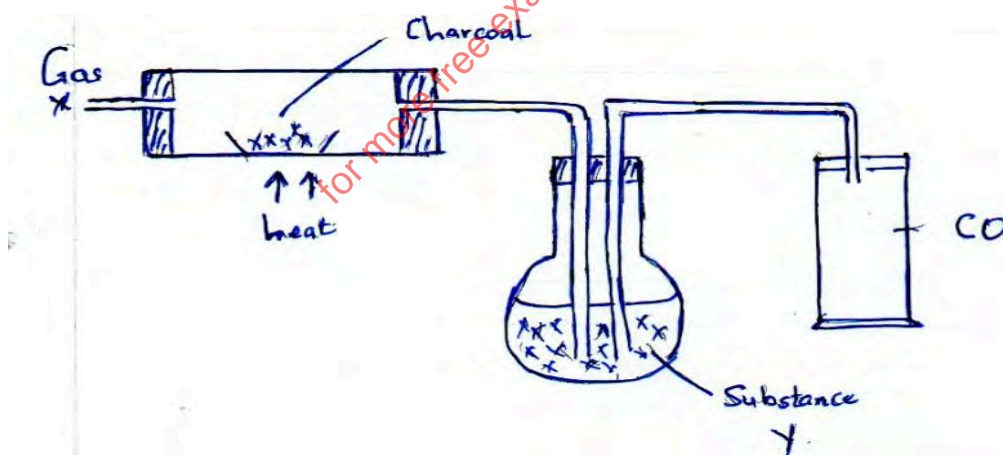

- a) Name Gas X _____ 1mk
 Substance Y _____ 1mk
- b) State the use of substance Y 1mk
- c) Name two mistakes in the set up 2mks
- d) Write down the equation for the reaction in the combustion tube 1mk
- e) How would you tell that the gas collected was actually CO. 1mk

CHEMISTRY PAPER 1,2 & 3

f) CO is a major pollutant in big towns

i. What is the major source of pollution in big towns

1mk

ii. Explain why CO is poisonous to human body.

2 mks

Q4. The flow chart below shows a process of manufacturing a fertilizer. Study it and answer the questions that follows;

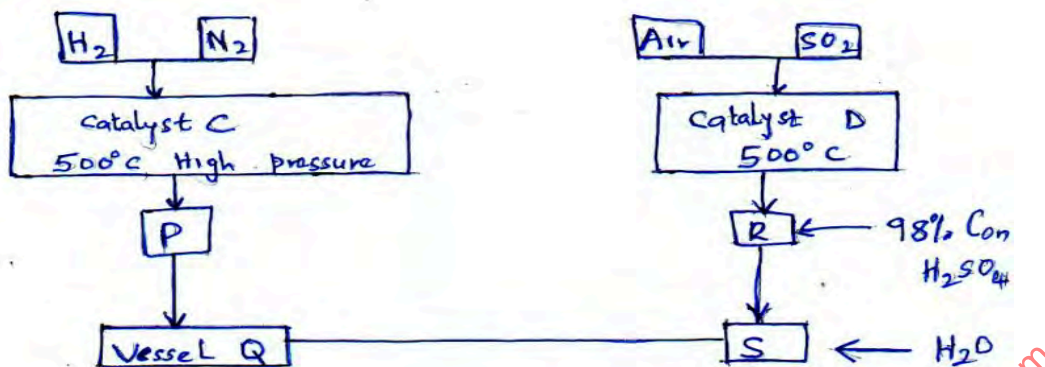

a) Name catalysts

C _____

½ mk

D _____

½ mk

b) i. Name the fertilizer formed

½ mk

ii. Identify the substances P and R

c) Name the process in which substance P is formed

½ mk

d) Write the chemical equation for the reaction at vessel Q

1mk

e) Explain why substance R is absorbed in 98% concentrated H₂SO₄ before adding water

2mks

f) Name the method by which pollution is controlled in contact process

1mk

g) Name one industry that can be set next to the plant.

½ mk

h) i. When hydrogen sulphide gas was bubbled through an aqueous solution of FeCl₃ yellow precipitate was deposited.

I) State another observation that was made

1mk

II) Write the equation for the reaction that took place

1mk

III) Explain why old papers slowly turns brownish when exposed to air and sunlight.

1mk

Q5. a) Define the following terms

2mks

i. Duplet

ii. Hydrogen bonding

b) Below is a flow chart. Study it and answer the questions that follow.

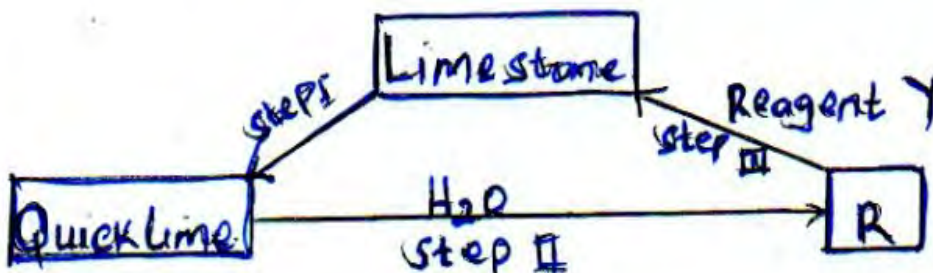

i. Name the process in step I.

1mk

ii. Name: Compound R _____
Reagent Y _____

1mk

1mk

CHEMISTRY PAPER 1,2 & 3

- iii. Write equation for reaction in step II 1mk
- (c) Explain why 0.1M hydrochloric acid has a PH of 1 while 0.1M ethanoic aci has a PH of 3. (2mks)
- d) i. Write down the observation made when a sample of copper (II) carbonate is heated in a test tube. Explain (2mks)
- ii. Write an equation for the action of heat on copper (II) carbonate 1mk

Q6. The table below shows results recorded on an experiment carried out to determine the solubility of potassium nitrate.

Temperature ⁰ C	20	30	40	50	60	70	80	90
Solubility in g/100g of H ₂ O	32	46	64	86	110	138	169	202

- a) Use the data above to plot a graph or solubility against temperature on the grid provided. 3mks
- b) From the graph determine the solubility of potassium Nitrate at:
- i) 25⁰ 1mk
- ii) 83⁰C 1mk
- c) What mass of potassium nitrate will crystalize when a saturated solution is cooled from 75⁰C to 20⁰C 2mks
- d) On the same axis sketch a graph showing solubility of chlorine gas varies with temperature 1mk
- e) The table below represents results of four samples of water. Study it and answer the questions that follow.

Sample of water	Drops of soap used to produce lather	
	Before boiling	After boiling
A	20	10
B	3	3
C	15	3
D	20	20

- i) Which sample is likely to be temporary hard water? Explain 2 mks
- ii) Give two advantages or hard water. 2mks
- Q7. The set up below was used by a group four students in an experiment. The readings of the balance before and after the experiment were 10.5g and 1.0g respectively. Given that the initial temperature and final temperature of water were 26.7⁰C and 28.0⁰C respectively. (specific heat capacity of water is 4200Jkg⁻¹K⁻¹)

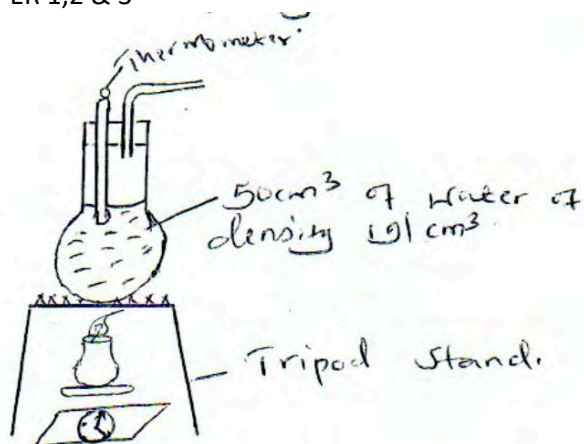

Determine;

- | | |
|--|------|
| a) Temperature change that occurred | 1mk |
| b) Amount of ethanol used | 1mk |
| c) Moles of ethanol used | 1mk |
| d) Amount of heat gained by water | 1mk |
| e) Molar enthalpy of combustion of ethanol | 2mks |

f) Use the following thermochemical process to answer the questions that follow;

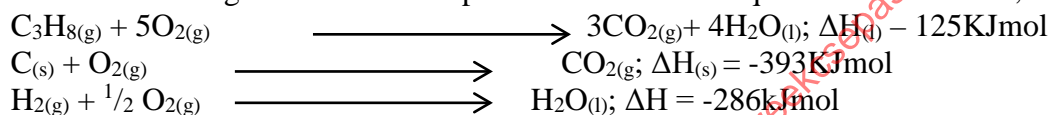

- i) Draw an energy level diagram representing the formation and combustion process of propane, carbon and hydrogen (2mks)
- ii) Hence or otherwise, determine the heat of formation of propane (2mks)

CEKENA
CHEMISTRY
233/3

CONFIDENTIAL

Each candidate requires:

- Exactly 3g of solid A
- 60cm³ of solution B
- Burette
- Pipette
- Pipette filler
- Source of heat
- Thermometer (-10⁰ – 110⁰C)
- Distilled water
- 250ml volumetric flask
- 250ml conical flask
- Spatula
- 1.2g solid M
- 0.5g solid R
- 6 test tubes
- 3 boiling tubes

CHEMISTRY PAPER 1,2 & 3

16. Glass rod
17. 1cm aluminium foil
18. 1 red and 1 blue litmus paper
19. Test tube holder
20. Filter paper
21. Filter funnel

ACCESS TO

- ✓ 2M NaOH
- ✓ 2M H₂SO₄
- ✓ 2M Pb(CNO₃)₂
- ✓ 2M HNO₃
- ✓ 2M KI
- ✓ 0.06 acidified KMnO₄
- ✓ Solid potassium carbonate
- ✓ Hot water bath in a 500ml glass beaker
- ✓ Solid A – Oxalic acid (hydrated)
- ✓ Solution B – 0.06m potassium manganate (VII) made by dissolving 9.48g of KMnO₄ crystals in 400cm³ of 2M H₂SO₄ acid and diluting to 1 litre with distilled water.
- ✓ Solid M – mixture of NaNO₃ and PbCO₃ in the ratio of 1:2 respectively
- ✓ Solid R – maleic acid

NB: - Ensure all apparatus are thoroughly cleaned.

- Ensure the filter papers are of good quality and working

CEKENA

233/3

CHEMISTRY PAPER 3

PRACTICAL

1. You are provided with:

- 3g of solid A
- Solution B, 0.06M acidified potassium manganate (VII) solution

You are required to determine:

- a) The solubility of solid A at different temperatures.
- b) The number of moles of water of crystallization in solid A

PROCEDURE

Carefully transfer all the solid A into a boiling tube. Using a burette, add 2cm³ of distilled water to solid A in the boiling tube. Heat the mixture in a hot water bath while stirring gently with a thermometer until all solid A dissolves.

Allow the solution to cool while stirring with the thermometer. Note the temperature at which crystals of solid A first appear. Record this temperature in the table below.

Using the burette, add 2cm³ of distilled water to the contents of the boiling tube. Warm the mixture again in the hot water bath while stirring with the thermometer note and record the dissolved. Allow the mixture to cool while stirring with the thermometer, note and record the temperature at which crystals of solid A first appear in the table 1 below. Repeat the procedure by adding 2cm³ portions to complete the table below.

Retain the contents of the boiling tube for use in procedure II

Table 1

Volume of water in the boiling tube (cm ³)	Temperature at which crystals of solid A first appear (°C)	Solubility of solid A (g/100g water)
2		
4		
6		
8		
10		

(4 mks)

- (a) Complete the table by calculating the solubility of solid A at different temperatures (2^{1/2} mks)
- (b) On the grid provided, plot a graph of solubility of solid A (vertical axis) against temperature. (3 mks)
- (c) Use your graph to determine;
- The solubility of solid A at 54°C (1 mk)
 - The mass of A that will crystallise when a saturated solution at 62°C is cooled to 40°C. (1 mk)

PROCEDURE II

Transfer all the contents of the boiling tube into a 250ml volumetric flask. Rinse both the boiling tube and the thermometer with distilled water and add the rinsing water to the volumetric flask. Add more water to the volumetric flask to make up to the mark. Label this solution A. Fill the burette with solution B. Using a pipette and pipette filler, place 25cm³ of solution A into a conical flask. Warm the mixture to 60°C. Titrate the hot solution A with solution B until a permanent pink colour just appears. Record your readings in the table below. Repeat the titration 2 more times to complete the table below.

	I	II	III
Final burette reading (cm ³)			
Initial burette reading (cm ³)			
Volume of solution B used (cm ³)			

(4 mks)

- Calculate the average volume of solution B used. (1 mk)
- Calculate the number of moles of potassium manganate (VII), solution B, used. (1 mk)
- Calculate the number of moles of A in 25cm³ of solution given that 2 moles of potassium manganate (VII) react completely with 5 moles of A. (1 mk)
- Calculate the relative formula mass of Q (1 mk)
- The formula of A has the form F.xH₂O. Determine the value of x in the formula given that the relative formula mass of F is 90. (O = 16, H = 1) (1 mk)

2. You are provided with solid M. Place it in a boiling tube, add 10cm³ of distilled water, shake and filter. Preserve the residue and filtrate for the tests below.

Observation
(1 mk)

Inference
(1 mk)

CHEMISTRY PAPER 1,2 & 3

(a) Divide the filtrate into five portions.

(i) To the first portion, add two drops of 2M sodium hydroxide, then add the alkali in excess.

Observation ($\frac{1}{2}$ mk)	Inference (1 mk)
------------------------------------	---------------------

(ii) To the second portion, add two drops of dilute sulphuric (VI) acid

Observation ($\frac{1}{2}$ mk)	Inference (1 mk)
------------------------------------	---------------------

(iii) To the third portion, dip a glass rod and burn over a non-luminous flame

Observation ($\frac{1}{2}$ mk)	Inference ($\frac{1}{2}$ mk)
------------------------------------	----------------------------------

(iv) To the fourth portion add two drops of lead (II) nitrate

Observation ($\frac{1}{2}$ mk)	Inference (1 mk)
------------------------------------	---------------------

(v) To the fifth portion drop 1cm piece of aluminium foil, add three drops of sodium hydroxide. Place blue and red litmus paper at the mouth of tests tube and warm

Observation (1 mk)	Inference ($\frac{1}{2}$ mk)
-----------------------	----------------------------------

(b) Place all the residue in a boiling tube and add 6cm³ of dilute nitric (V) acid. Divide the solution into two portions

Observation (1 mk)	Inference ($\frac{1}{2}$ mk)
-----------------------	----------------------------------

(i) To the first portion add three drops of dilute sulphuric (VI) acid.

Observation ($\frac{1}{2}$ mk)	Inference (1 mk)
------------------------------------	---------------------

(ii) To the second portion add two drops of potassium Iodide.

Observation ($\frac{1}{2}$ mk)	Inference ($\frac{1}{2}$ mk)
------------------------------------	----------------------------------

3. You are provided with solid R. Carry out the test below and record the observation and inferences in the spaces provided.

(a) Place $\frac{1}{3}$ rd full solid R in a spatula and burn on a non-luminous flame

Observation (1 mk)	Inference (1 mk)
-----------------------	---------------------

(b)(i) Put the remaining portion of solid R into a clean test tube and add about 3cm³ of distilled water, shake and divide into 2 portions.

Observation (1 mk)	Inference ($\frac{1}{2}$ mk)
-----------------------	----------------------------------

(ii) To the 1st portion add 2 drops of acidified KMnO₄

Observation ($\frac{1}{2}$ mk)	Inference (1 mk)
------------------------------------	---------------------

(iii) To the 2nd portion add potassium carbonate.

Observation	Inference
-------------	-----------

($\frac{1}{2}$ mk)	(1 mk)
---------------------	--------

1. a) Distinguish between ionization energy and electron affinity. (1 mk)
 (b) The atomic number of Q and R are 9 and 17 respectively. Compare the electron affinity of Q and R. Explain. (2 mks)
2. The relative atomic mass of an element is 10.28; it has two isotopes $^{10}_5\text{R}$ and $^{11}_5\text{R}$. Calculate the relative percentage abundance of each isotope. (2mks)
3. Describe how solid Aluminum chloride can be separated from a solid mixture of sodium chloride and aluminium chloride. (3 mks)
4. The number of protons and neutrons of atoms W, X, Y and Z are shown in the table below.

Atom	No. of protons	No. of neutrons
W	6	6
X	12	12
Y	6	8
Z	17	20

- (a) Write down the electronic configuration of X. (1 mks)
 (b) (i) Which one of the atoms is of an element in group (VII) of the periodic table (1mk)
 (ii) Name the type of bond which is formed when X and Z reacts. (1 mk)
5. Sulphur exists in two crystalline forms
 (a) Name the two crystalline forms (1 mk)
 (b) Give any two uses of sulphur. (2 mks)
6. An experiment was set as shown below

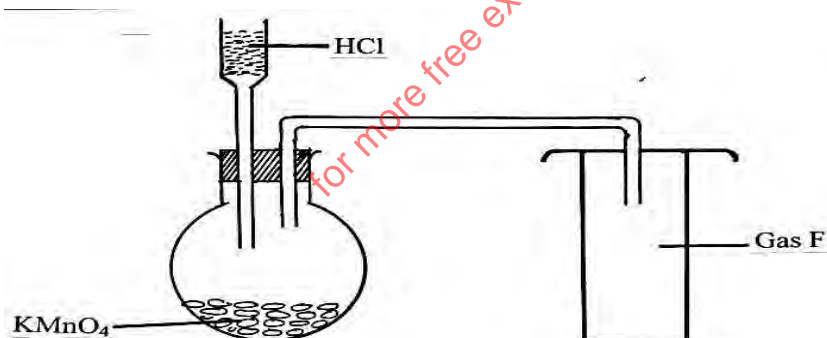

- a) Name the gas F (1 mk)
 b) State one physical characteristic of gas F. (1 mk)
 c) What would be observed if a blue litmus paper was put in a solution of gas F? (1 mk)
7. Below is a list of oxides.

MgO, CO, K₂O, CaO and Al₂O₃

From the above list select

- (a) A neutral oxide. (1 mk)
 (b) An oxide that can react with both potassium hydroxide and dilute hydrochloric acid. (1 mk)
 (c) What property is exhibited by the reaction in (b) above. (1 mk)

8. The apparatus shown below was used to investigate the effect of carbon II oxide on copper II oxide.

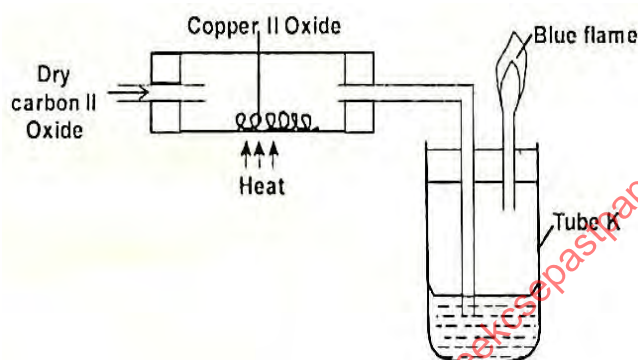

- a) State the observation that was made in the combustion tube by the end of the experiment. (1 mk)
 b) Write an equation for the reaction that took place in the combustion tube. (1mk)
 c) Why is it necessary to burn gas coming out of tube K? (1mk)
9. The table below shows properties of some chlorides. Study it and answer the questions that follow.

Chloride	Mp(°C)	BP (°C)	Electrical conductivity in aqueous solution	PH of solution
Al	-	183	Good	3
Na	860	1420	Good	7
P	32	75	Good	3
H	-146	-29	Good	1

- a) Explain the high melting and boiling points of sodium chloride. (1mk)
 b) Write an equation for the reaction between PCl₅ and water. (1mk)
 c) Draw the dot (•) and cross (x) diagram to show bonding in NaCl. (1 mk)

10. Excess Concentrated Sulphuric VI acid with pieces of dry wood as shown

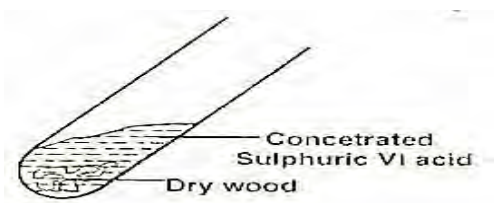

- a) State the observation made in the tube. (1mk)
 b) When the reaction was complete, the mixture was heated gently, then strongly and setup adjusted as shown below.

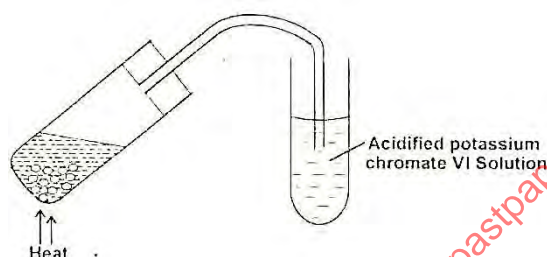

State and explain the observation made on acidified potassium chromate VI solution. (2mks)

11. The diagram below shows the set-up that can be used to prepare and collect oxygen gas. Study it and answer the questions that follow.

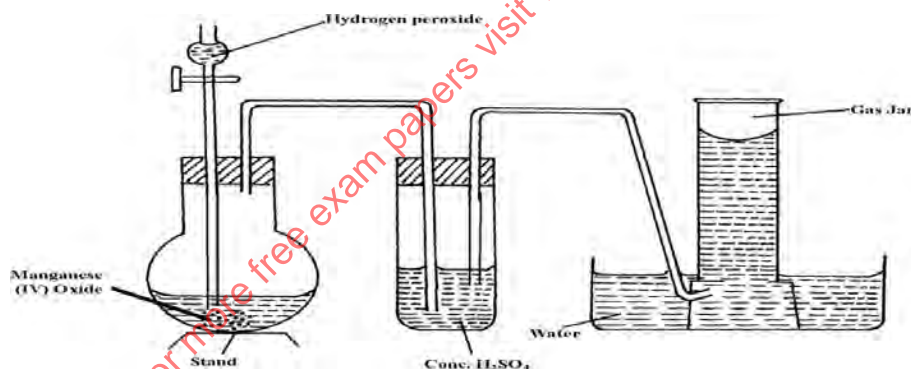

- a) Identify two mistakes from the diagram which must be corrected for one to collect **dry** oxygen gas. (2mks)
 b) What property of oxygen gas makes it possible to be collected overwater? (1mk)
12. When a grey powder P, which has no action on cold water, is placed into a salt solution of Q, a brown solid R is deposited. The blue solution of Q fades giving way to a green solution.
- a) Name the type of reaction that takes place. (1 mk)
 b) Identify solids P and R (1 mk)
 c) Write an ionic equation for the reaction leading to formation of the brown solid. (1mk)

13. Calculate the number of molecules of water of crystallization in oxalic acid crystals, $H_2C_2O_4 \cdot xH_2O$, from the following data: 5g of the crystals were made up to $250cm^3$. $25.0 cm^3$ of this solution required $15.9cm^3$ of 0.5M sodium hydroxide to neutralize it. (H=1, C=12, O=16, $H_2O=18$) (3mks)
14. The diagram below shows the heating curve of a pure substance. Study it and answer the questions that follow.

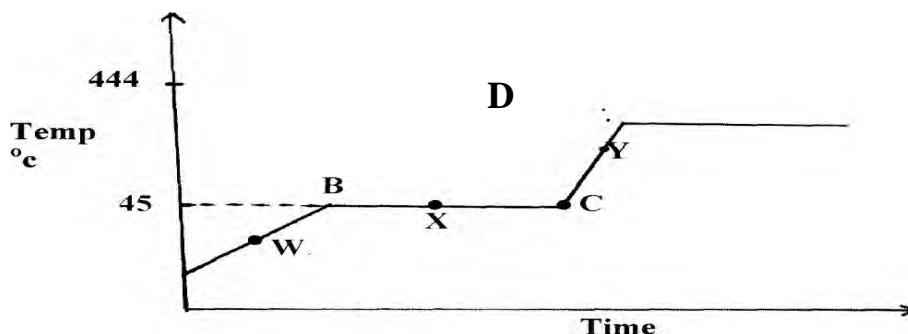

- (a) Explain why the temperature remains constant between points B and C. (1½mks)
- (b) Use kinetic theory to explain what occurs between C and D. (1½mks)
15. Study the chart below and answer the questions that follow.

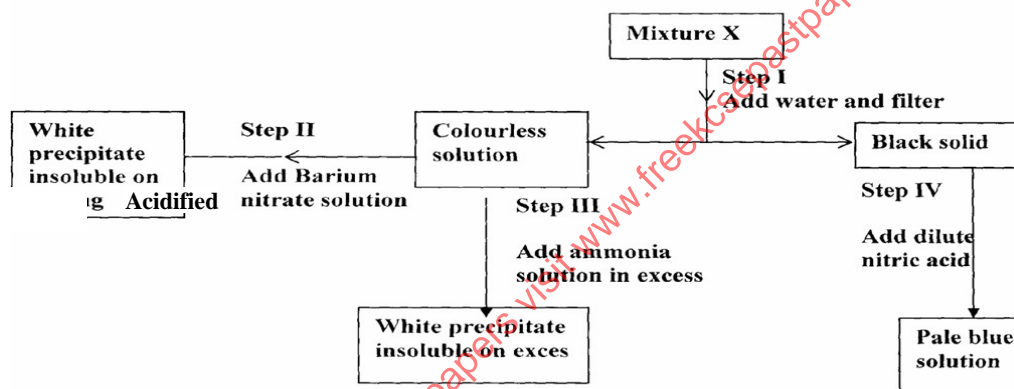

Name:

- (i) Cation present in mixture X (1mk)
- (ii) Anion present in the solution. (1mk)
16. When solid Zinc carbonate was added to a solution of hydrogen chloride in methylbenzene, there was no observable change. On addition of some water to the mixture there was effervescence. Explain these observations. (2mks)
17. (a) State the Gay Lussac's law (1 mk)
- B) What volume of methane would remain if a burner containing $40cm^3$ of methane burns in $40cm^3$ of enclosed air (assuming that oxygen is 20% of air)? (2 mks)
18. $60cm^3$ of oxygen gas diffused through a porous hole in 50 seconds. How long will it take $80cm^3$ of sulphur (IV) oxide to diffuse through the same hole under the same conditions (S = 32, O=16). (3mks)
19. When sulphur is heated in a boiling tube in the absence of air, the yellow crystals melt into a golden yellow mobile liquid at $113^\circ C$. The liquid turns into a dark brown viscous mass at $160^\circ C$. At $400^\circ C$ the brown liquid becomes less viscous and flows easily. Explain these observations. (3mks)

20. The graph below shows how the pH value of soil in a farm changed over a period of time.

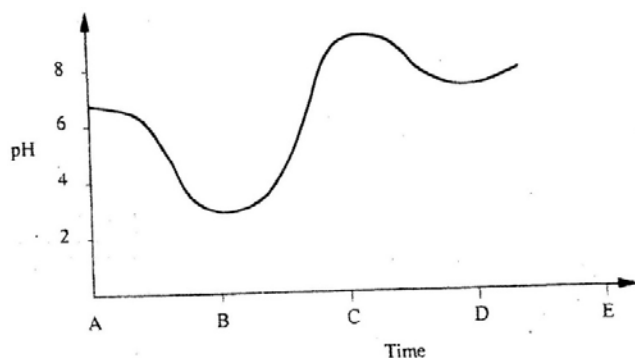

- a. Describe how the pH of the soil is determined. (2mks)
 b. State one factor that may have been responsible for the change in the soil PH in the time interval AB (1mk)

21. Study the information given in the table below and answer the questions below the table

Bond	Bond energy kJ/mole
C-H	414
Cl- Cl	244
C-Cl	326
H- Cl	431

Calculate the enthalpy change for the reaction (2mks)

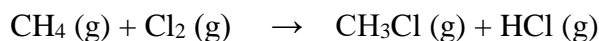

22. (a) $\text{Ca}(\text{s}) + \frac{1}{2} \text{O}(\text{g}) \rightarrow \text{CaO}(\text{s}) \quad \Delta H = -635 \text{ kJ/mole}$
 $\text{C}(\text{s}) + \text{O}_2 \rightarrow \text{CO}_2(\text{g}) \quad \Delta H = -394 \text{ kJ/mole}$
 $\text{Ca}(\text{s}) + \text{CO}_2(\text{g}) + \frac{3}{2} \text{O}_2 \rightarrow \text{CaCO}_3(\text{s}) \quad \Delta H = -1207 \text{ kJ/mole}$
 Calculate the enthalpy change for the reaction. (2 mks)
 $\text{CaO}(\text{s}) + \text{CO}_2(\text{g}) \rightarrow \text{CaCO}_3(\text{s})$
 b) Sketch an energy level diagram for the forward reaction (1 mk)

23. In a class experiment 5.0g of ethanol ($\text{CH}_3\text{CH}_2\text{OH}$) was completely burnt and all the heat evolved was used to heat 500cm^3 of water from 20°C to 80°C . Given that the specific heat capacity of water is 4.2J/g/k and the density of water is 1g/cm^3 .

- (i) Calculate the heat energy absorbed by water (2 mks)
 (ii) Find the molar heat of combustion of ethanol (2 mks)
 (C= 12) (H= 1) (O= 16)

24. Study the flow chart below and answer questions that follow

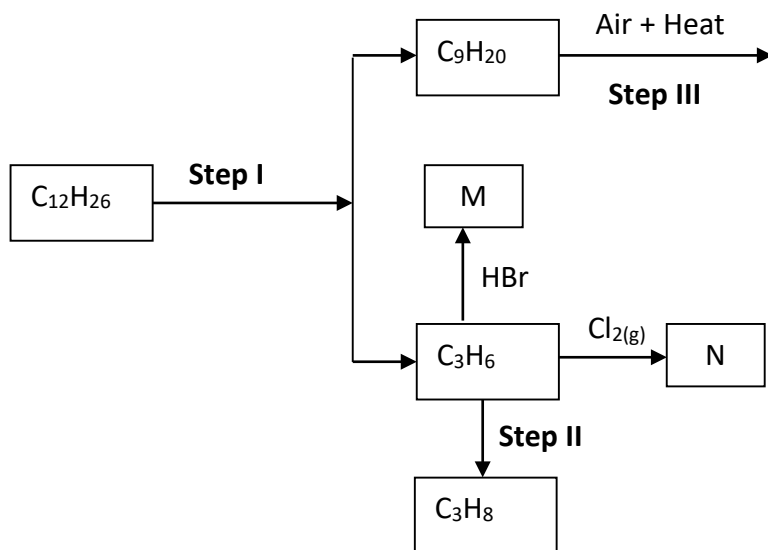

(a) Name the process labeled in steps above

Step I

(1/2mk)

Step II

(1/2mk)

(b) State the physical condition required for step I to occur.

(1mk)

(c) Name the reagent and state the conditions required for step II to occur.

(1mk)

25. The figure below shows the variation in rates of the following reaction,

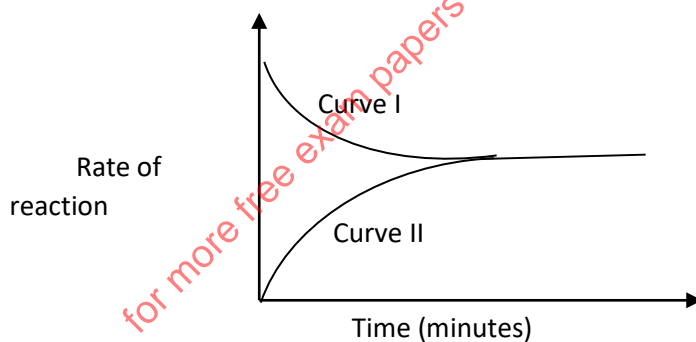
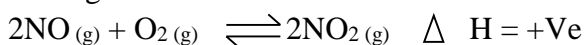

Other than concentration of either reactants or products, identify two other factors that can affect the rate of reaction above. Explain your answer. (2mks)

26. Study the set-up below and then answer the questions that follow.

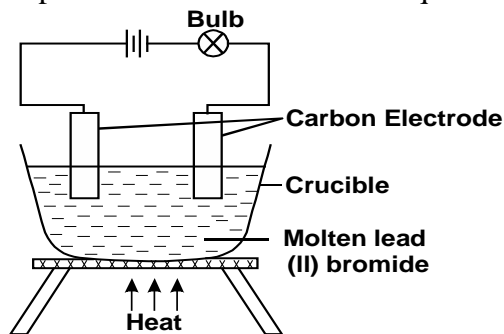

a) Define a binary electrolyte

(1mk)

b) State and explain the observation that would be made at the anode when the circuit is completed.

(2 mks)

27. The curves below represent the change in mass when equal masses of powdered magnesium and magnesium ribbon were reacted with excess 2M hydrochloric acid. Study them and answer the questions below

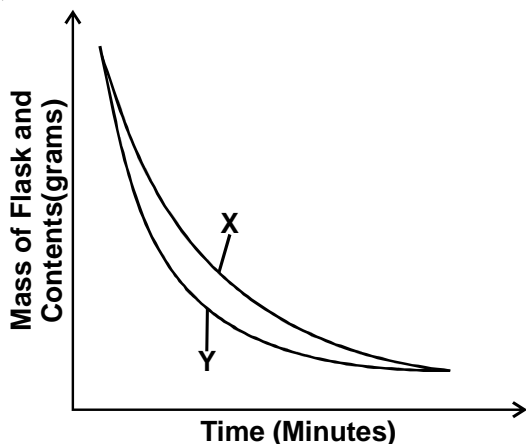

Which curve represents the reaction with magnesium powder? Explain your answer.

(2 mks)

Study the information in the table below and answer the questions that follow.

Salt	Solubility g/100g of water	
	at 40°C	of 60°C
CuSO ₄	28	38
Pb(NO ₃) ₂	79	98

A mixture containing 35g of CuSO₄ and 78g of Pb(NO₃)₂ in 100g of water at 60°C was cooled to 40°C.)

a) Which salt crystallised out? Give a reason.

(2 mks)

b) Calculate the mass of the salt that crystallized out.

(1 mk)

Ammonium nitrite was heated as shown in the set-up below.

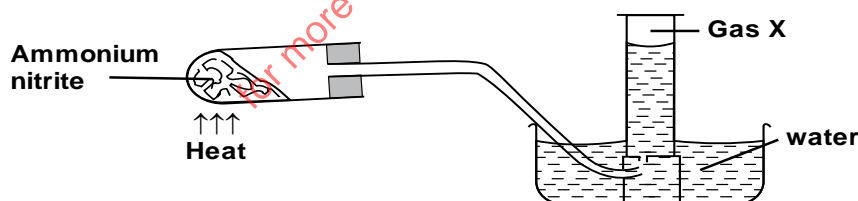

a) Identify, gas X.

(1 mk)

b) State and explain the precaution that must be taken before heating is stopped.

(1 mk)

CHEMISTRY PAPER 1,2 & 3
TRIAL II CLUSTER
 233/2
CHEMISTRY PAPER 2

1. The grid below shows a section of the periodic table, the letters are not the actual chemical symbol.

K	L			M		N	P	
	Q			R	S	T	V	
W								

- Name the family into which element P belongs to (1mark)
- Which two elements forms the most soluble carbonates (2marks)
- With a reason, identify elements in period 3 with the largest atomic radius (2marks)
- Write the formula of the compound formed between Q and M (1mark)
- State two uses of element R and for each use, state property of element R that makes its possible for the use
- Using dots and cross, show bonding in the compound formed between R and oxygen (2marks)
- In terms of structure and bonding, explain why the oxides of element T has relatively low boiling points. (2marks)

2.(a) The results below were obtained in an experiment conducted by form 3 students from Ratansi secondary School using magnesium

Mass of the crucible + Lid = 19.52g

Mass of the crucible + Lid + magnesium ribbon = 20.36g

Mass of the crucible + Lid + magnesium oxide = 20.92g

- Use the results to find the percentage mass of magnesium and oxygen in magnesium oxide. (2marks)
 - Determine the empirical formula of magnesium oxide. (Mg = 24.0, O = 16.0) (2marks)
- b) Sodium hydroxide pellet were accidentally mixed with sodium chloride, 8.8g of the mixture were dissolved in water to make one litre of solution. 50cm³ of the solution was neutralized by 20.0cm³ of 0.25M sulphuric (VI) acid.
- Write an equation for the reaction that took place. (1mark)
 - calculate the:
 - Number of moles of the substance that reacted with sulphuric (VI) acid (1mark)
 - Number of moles of the substance that would react with sulphuric (VI) acid in the one litre solution (1mark)
 - The percentage of sodium chloride in the mixture. (2marks)
- c). The reaction between Nitrogen and Hydrogen can be represented as shown in the energy cycle given below

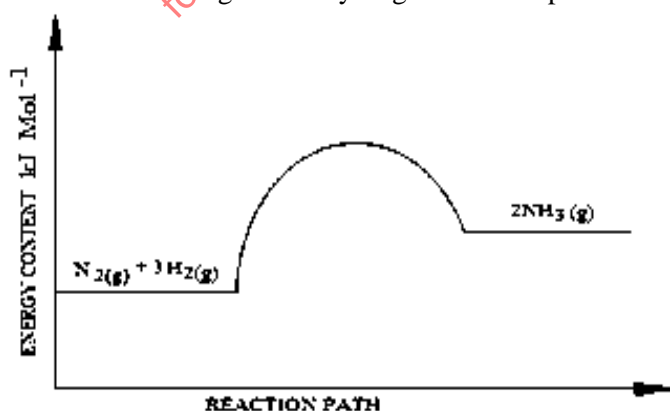

Explain how the yield of Ammonia would be affected if

- Temperature was reduced (2marks)
- Pressure was increased (2marks)

3. The flow chart below represents preparation and properties of oxygen gas. Study it and answer the question that follow. ++

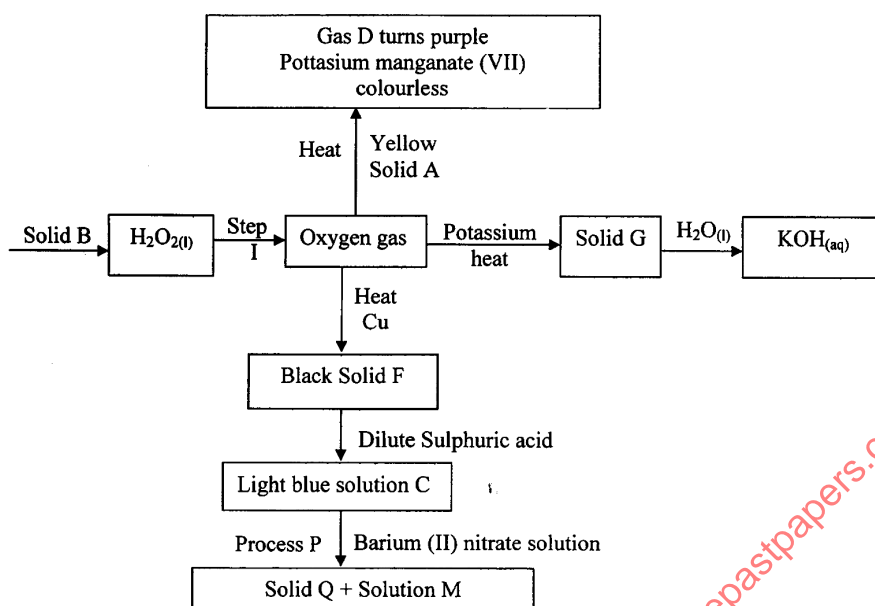

- i) Identify the following substances (2marks)
 - a. Solid A
 - b. Gas D.
 - c. Solid Q.
 - d. Solution M.
 - ii) Write a chemical equation for the reaction in step I. (1mark)
 - iii) Write chemical equation for the formation of the following compound. (3marks)
 - a. Solid G.
 - b. Gas D.
 - c. Light blue solution C.
 - iv) State the confirmatory test for oxygen gas. (1mark)
 - v) Write the ionic equation for reaction taking place in process P. (1mark)
 - vi) State one use of oxygen. (1mark)
- 4.(a) When steam is passed over heated charcoal as shown below, Carbon (II) oxide and hydrogen gas are formed

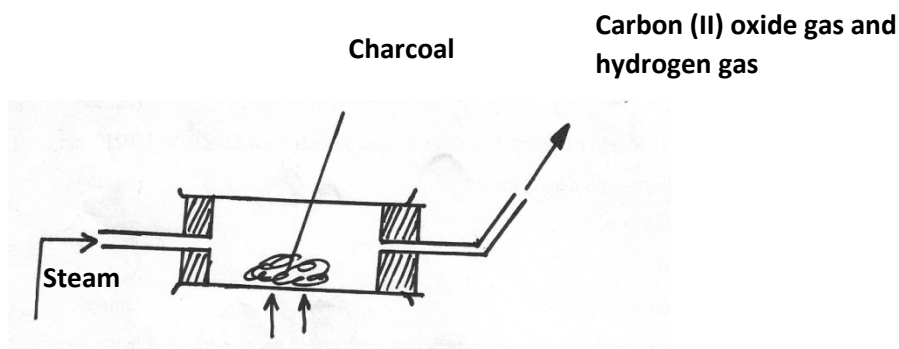

- (i) What name is given to the mixture of gases produced above? (1mark)
- (ii) Give two uses of Carbon (II) oxide gas which are also uses of hydrogen gas (1mark)

(b) The diagram below represents a charcoal burner. Study it and answer the questions that follow

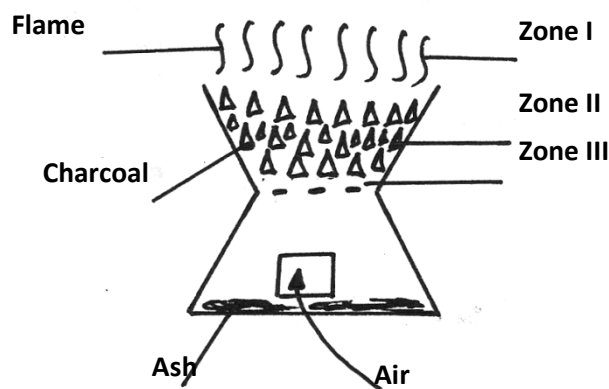

(i) Write equations for the reactions occurring at

Zone I..... (1mark)

Zone II..... (1mark)

(ii) What is the colour of the flame (1mark)

(iii) The ash that collects in the lower compartment was dissolved in water and filtered. Suggest the PH value of the resulting solution (1mark)

(c) Carbon (II) oxide gas can be prepared in the laboratory by a process shown below

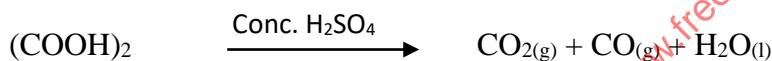

(i) State the function of the concentration sulphuric (VI) acid in the process above (1mark)

(ii) How would you remove Carbon (IV) oxide gas form the mixture of Carbon (II) Oxide and carbon (IV) oxide gas (1mark)

(d) What volume of Carbon (II) Oxide at r.t.p is needed to reduce 106g Iron (III) Oxide to iron metal? (O=16, Fe=56, Molar gas volume at r.t.p=24 litres) (3marks)

8).1g of magnesium ribbon was reacted with hydrochloric acid at room temperature in order to investigate how the rate of reaction varies with time. The results obtained were recorded as shown below.

Time (seconds)	0	20	40	60	80	100	120	140	160	180
Volume of gas produced (cm ³)	0	10	20	26	32	35	38	39	40	40

(a)(i) On the graph provided, plot a graph of volume of gas produced against time taken. Label the graph K. (3 Marks)

(ii) From the graph determine the rate of production of the gas at 110 seconds. (2 Marks)

(b) On the same axis sketch the graph you would expect to obtain if:-

(i) The same mass of powdered magnesium was used instead of magnesium ribbon. Label the graph Y. (1 Mark)

(ii) If the temperature of the solution mixture was reduced from 25⁰C to 15⁰C. Label the graph Z. (1 Mark)

(c) Determine the mass of magnesium ribbon that remained unreacted in this experiment

(Mg = 24, Molar gas volume = 24dm³ at r.t.p) (3 Marks)

1. Study the scheme below and answer the questions that follow.

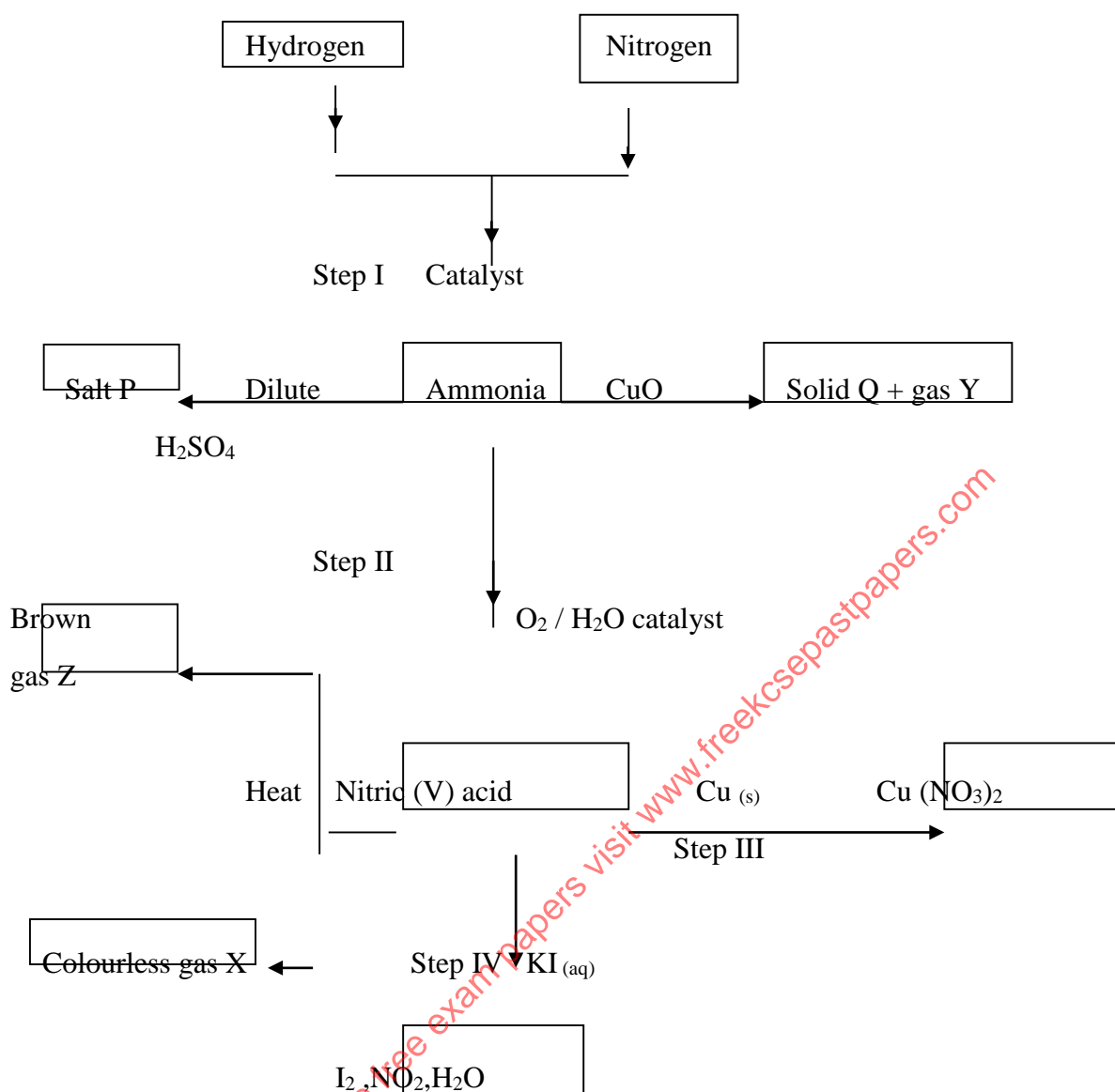

- (a) State
- The process taking place in step I. (1 mark)
 - One condition that would favour step I. (1 mark)
- (b) Name the catalyst which could be used in steps I and II. (2 marks)
- (c) Give the names of:
- Salt P _____ ($\frac{1}{2}$ mark)
 - Solid Q _____ ($\frac{1}{2}$ mark)
 - Gases X and Z (1 mark)
- (d) Write two equations for the reactions that take place in step II. (2 marks)
- (e) Name the oxidizing agent in the reaction that takes place in step IV. (1 mark)
- (f) Why is concentrated nitric (V) acid stored in dark bottles in cool places?. (1 mark)
- (g) Give one industrial use of nitric (V) acid. (1 mark)
- 7.(a) (i) Apart from ethanol, name two liquid fuels. (1 mark)

(ii) State two factors that should be considered when choosing a fuel for cooking. (2marks)

(iii) The set up below was used to determine the molar heat of combustion of ethanol.

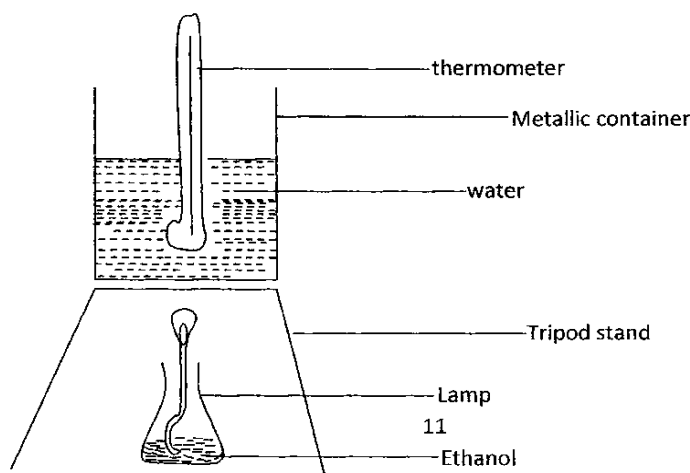

During the experiment, the data given below was recorded.

Volume of water = 500cm^3

Initial temperature of water = 25°C

Final temperature of water = 46.5°C

Mass of ethanol + lamp before burning = 125.5g

Mass of ethanol + lamp after burning = 124.0g

Calculate;

- (i) Heat evolved during the experiment (Density of water = 1g/cm^3 , specific heat capacity of water = 4.2J/g.k.) (3 marks)
- (ii) Molar heat of combustion of ethanol (C = 12.0, O = 16.0, H = 1.0) (2 marks)
- (c) Write the equation for the complete combustion of ethanol. (1 mark)
- (d) The experiment value of molar heat of combustion of ethanol obtained in (b) (ii) above is lower than the theoretical value. Give two reasons for this variation. (2 marks)
- (e) Why is the water in the container continuously stirred with thermometer? (1 mark)

FORM 4 JOINT EXAMINATION 2020

CHEMISTRY P3 INSTRUCTIONS TO SCHOOLS.

Other than the fittings and apparatus found in the chemistry laboratory, the chemistry teacher is under instructions to provide the following to each student;

- About 100cm^3 of solution **S**.
- About 100cm^3 of solution **P**.
- About 80cm^3 of solution **Y**.
- About 60cm^3 of solution **X**.
- Burette.
- Pipette.
- 2 Conical flasks.
- 6 clean and dry test tubes in a test tube rack.
- 2 boiling tubes.
- 10 ml measuring cylinder.
- 50ml measuring cylinder.
- Thermometer. (-10°C - 110°C).
- One 200ml plastic beaker.
- One test tube holder.

CHEMISTRY PAPER 1,2 & 3

- One filter paper.
- Metallic spatula.
- Distilled water in a wash bottle.
- Universal indicator solution.
- PH Chart (0-14).
- About 2g Sodium hydrogen carbonate.
- About 2g of solid U (Mixture of Sodium chloride and Zinc chloride in the ratio 1:1).
- About 2g of solid T-Oxalic acid

ACCESS TO:

- Source of heat.
- 2M NaOH Supplied with a dropper.
- 2M Pb(NO₃)₂ solution.
- 2 M aqueous Ammonia.
- Acidified Potassium Chromate (VI) supplied with a dropper.
- Acidified potassium manganate (VII) supplied with a dropper.

NOTES:

1. Solution P is prepared by accurately weighing 20g of sodium hydroxide pellets and dissolving it in 600 cm³ of distilled water and made up to 1 litre.
2. Solution X is prepared in the same way as solution P above.
3. Solution Y is prepared by accurately weighing 31.5g of Oxalic acid and dissolving in 600cm³ of distilled and made up to 1 litre.

Trial 2

233/3 CHEMISTRY PRACTICAL PAPER 3

1. You are provided with:

- **Sodium hydroxide solution labeled P**
- **0.025M Solution of sulphuric (VI) acid labeled S**
- **Oxalic acid solution labeled Y**

You are required to determine

- 1. The concentration of the Sodium hydroxide solution labeled P in moles per liter.**
- 2. The molar heat of neutralization of sodium hydroxide w**

Procedure I

Fill the burette with solution **S** up to the mark. Pipette 25.0cm^3 of solution **P** into a clean 250cm^3 conical flask. Add 3 drops of phenolphthalein indicator and titrate with solution **S** till end point. Record your reading in the table below. Repeat the experiment two more times and complete the table

Table 1

	I	II	III
Final burette reading(cm^3)			
Initial burette reading (Cm^3)			
Volume of solution S used (Cm^3)			

- (a) Determine the average volume of solution S used (4mks)
(1mk)
- (b)i) Determine the number of moles sulphuric (VI) acid labeled S used (1 mark)
- ii) Calculate the number of moles sodium hydroxide, solution P required to neutralize the moles of acid in b i) above (1mk)
- c) Determine the concentration of the sodium hydroxide solution P in moles per litre (1 mark)

PROCEDURE II:

- Place six test tubes in a test tube rack. Using a 10cm^3 measuring cylinder, measure 10cm^3 of solution P and place them into each of the test tubes.
- Measure 20cm^3 of solution Y using a measuring cylinder and place into 200cm^3 beaker. Measure the steady temperature of solution Y and record it in table II below.
- Put the first portion of the 10cm^3 of solution P from the test tube into the beaker containing 20cm^3 of solution Y. Stir the mixture carefully using a thermometer and record the highest temperature reached by the mixture in table II below.
- Pour the second portion of solution P **into the mixture in the beaker in step 3 above**, stir and record the highest temperature of this mixture in the table II.
- Continue this procedure using the remaining portions of solution P to complete table II.

Table II

Volume of Y (cm^3)	20	20	20	20	20	20	20
Total volume of P added (cm^3)	0	10	20	30	40	50	60
Highest temperature of mixture($^{\circ}\text{C}$)							

(4 mks)

- (ii) On the grid provided, plot a graph of temperature (Y axis) against volume of solution P (3mks)
- (iii) From the graph, find:
- (a) The volume of solution P required to neutralize 20cm^3 of oxalic acid solution Y (1 mk)
- (b) The highest temperature change (ΔT) (1 mk)
- (iv). Calculate the heat change of reaction

CHEMISTRY PAPER 1,2 & 3

(Assume density of mixture = 1g/cm^3 and specific heat capacity = $4.2\text{Jg}^{-1}\text{k}^{-1}$) (2 marks)

(v) Determine the molar heat of neutralization of sodium hydroxide, solution P (2 marks)

2. You are provided with **solid U**. Carry out the following tests and record your observations and inferences in the spaces provideda) Place the entire solid in a clean dry boiling tube. Add about 10cm^3 distilled water and shake. Filter the solution and retain both the filtrate and the residue

Observation	Inferences
(1mark)	(1mark)

b) Divide the filtrate into three portions; to the first portion add dilute sodium hydroxide solution drop wise until in excess

Observation	Inferences
(1mark)	(1mark)

c) Dip a clean spatula into the second portion of the filtrate and ignite it on a non-luminous flame of the Bunsen burner

Observation	Inferences
(1mark)	(1mark)

d) To the third portion of the filtrate, add lead (II) nitrate then warm gently

Observation	Inferences
(1mark)	(1mark)

e) To the residue add dilute nitric (V) acid and divide the solution into three portions.

i) To the first portion add aqueous ammonia solution drop wise until in excess.

Observation	Inferences
(1mark)	(1mark)

ii) To the second portion add four drops of lead(II) nitrate solution

Observation	Inferences
(1mark)	(1mark)

iii) To the third portion add a few drops of potassium dichromate (VI) solution

Observation	Inferences
(1mark)	(1mark)

3. You are provided with **an organic solid T**. Carry out the tests below, your observations and inferences in the spaces provided.

a) Using a clean spatula heat about a third of solid T in a non luminous flame of he Bunsen burner

Observation	Inferences
(1mark)	(1mark)

b) i) Add about 10cm³of distilled water to the remaining portion of solid T in a test tube and divide the solution into three portions

Observation	Inferences
(1mark)	(1mark)

ii) To the first portion, add two drops of acidified potassium manganate (VII) solution

Observation	Inferences
(1mark)	(1mark)

iv) To the second portion, add a small amount of solid sodium hydrogen carbonate provided.

Observation	Inferences
(1mark)	(1mark)

v) Using the third portion determine the pH of the solution.

Method used	Inferences
(1mark)	(1mark)

CHEMISTRY PAPER 1,2 & 3
MERU CENTRAL CLUSTER EXAMS
233/1
CHEMISTRY
PAPER 1
(THEORY)

1. The electronic arrangement of ions x^{3+} and y^{2-} are 2.8 and 2.8.8 respectively
- Write the electronic arrangement of the elements x and y. (3 marks)
 - Write the formula of the compound that would be formed between x and y. (1 mark)
2. When bromine gas reacts with aqueous Sodium hydroxide, the equilibrium represented by the equation;

$$\text{Br}_{2(aq)} + 2\text{OH}^{-}(aq) \rightleftharpoons \text{Br}^{-}(aq) + \text{OBr}^{-}(aq) + \text{H}_2\text{O}$$
is established.

What observations would be made if a few drops of sulphuric (VI) acid were added to the equilibrium mixture? (2 marks)

3. Calculate the amount of calcium carbonate that would remain if 15.0g of calcium carbonate were reacted with 0.2g moles of hydrochloric acid. The equation for the reaction is,

$$\text{CaCO}_{3(s)} + 2\text{HCl} \longrightarrow \text{CaCl}_{2(aq)} + \text{CO}_{2(g)} + \text{H}_2\text{O}_{(g)}$$
(C = 12.0, O = 16, Ca = 40.0) (3 marks)
4. In an experiment, soap solution was added to three separate samples of water. The table below shows the volumes of soap solution required to form lather with 1000cm³ of each sample of water before and after boiling.

	Sample 1	Sample 2	Sample 3
Volume of soap before water is boiled	27.0	3.0	10.6
Volume of soap after water is boiled	27.0	3.0	3.0

- Which water sample is likely to be soft? Explain. (2 marks)
 - Explain the change in the volumes of soap solution used in sample (iii). (1 mark)
5. Ammonia gas was passed into water as shown.

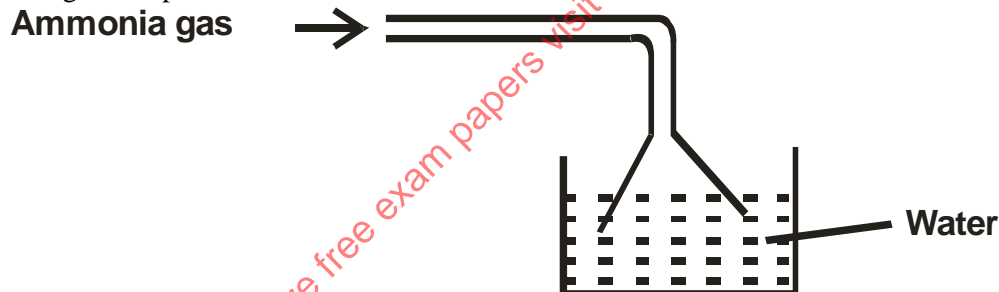

- When a red litmus paper was dropped into the resulting solution, it turned blue. Give a reason for this observation. (1 mark)
 - What is the function of the funnel? (1 mark)
6. The table below gives some properties of gases D and E.
- | Gas | Density | Effects of H ₂ SO ₄ | Effects of NaOH |
|-----|------------------|---|----------------------------|
| D | Lighter than air | Reacts to form a salt | Dissolves without reacting |
| E | Heavier than air | Not affected | Not affected |
- Describe how you would obtain a sample of E from a mixture of gases D and E. (2 marks)
 - Suggest a possible identity of gas D. Give a reason for your answer. (1 marks)

7. The curve below represents the variation of temperature with time when pure and impure samples of a solid were heated separately.

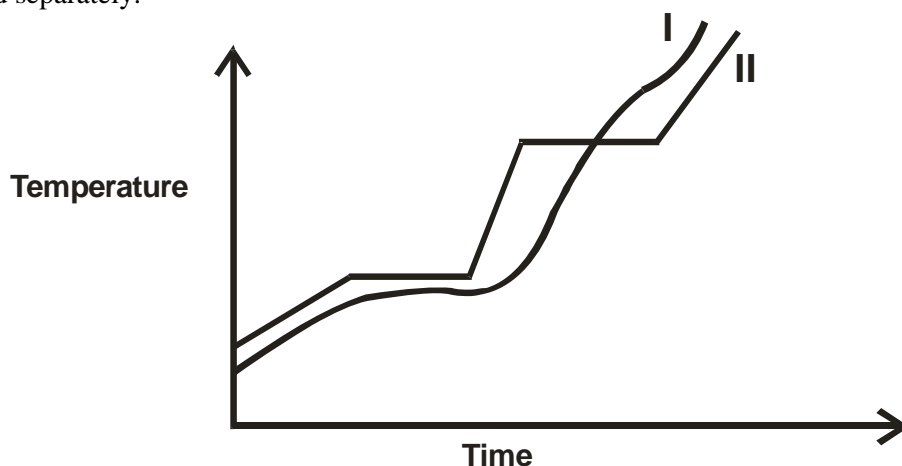

Which curve shows the variation in temperature for the pure solid? Explain.

(2 marks)

8. The diagram below represent set-up that can be used to prepare and collect oxygen gas.

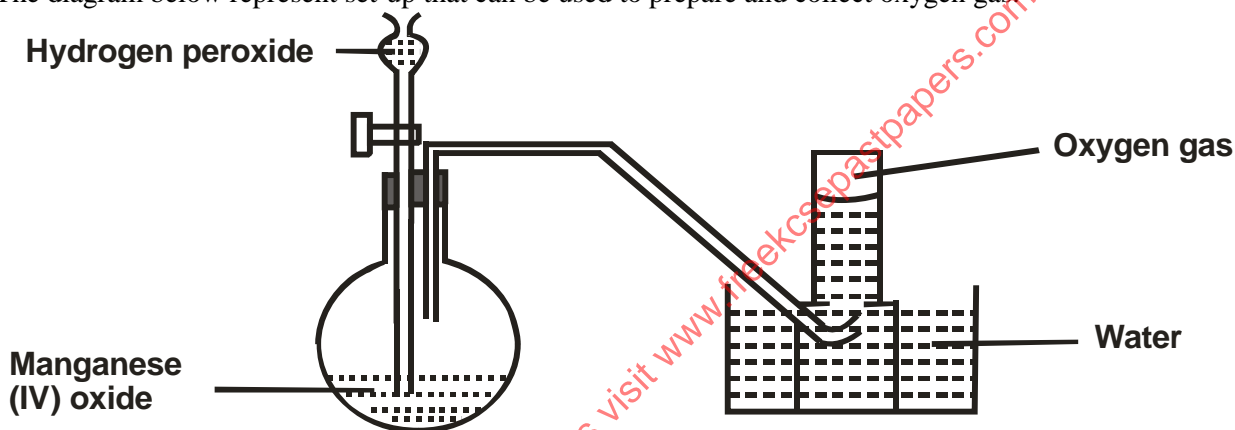

a) Write an equation for the reaction that takes place. (1 mark)

b) What property of oxygen makes it possible for its collection as indicated by the diagram? (1 mark)

(1 mark)

c) Explain why it is important not to collect gas for the first few seconds of the experiment. (1 mark)

9. Study the set-up below and answer the questions that follow.

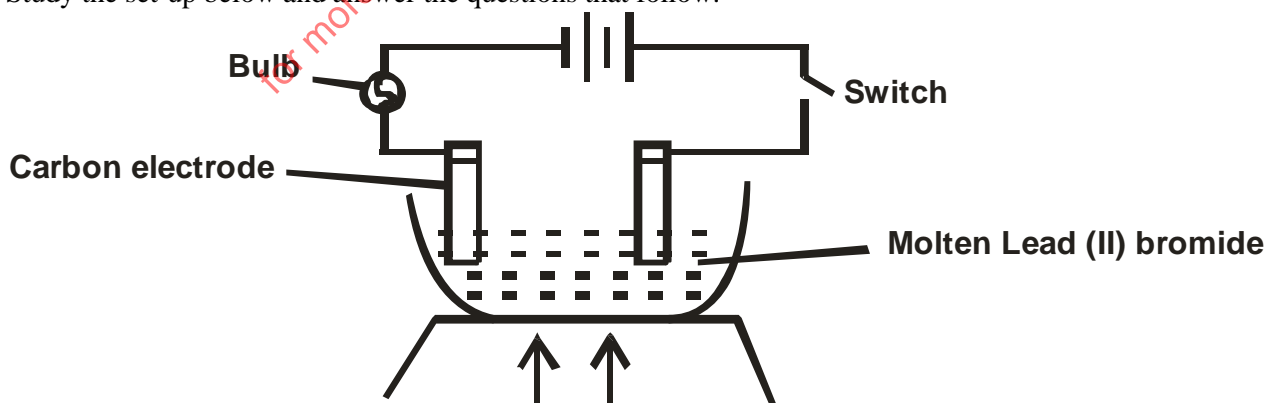

State and explain the observation that would be made when the circuit is completed.

(3 marks)

CHEMISTRY PAPER 1,2 & 3

10. In an experiment, rods of metals P, Q and R were cleaned with sand paper and placed in a beaker containing water. Another set of rods was also cleaned and placed in a beaker containing dilute acid. After placing the rods in the two liquids, bubbles of gas were seen around some of the rods as shown in the diagrams below.

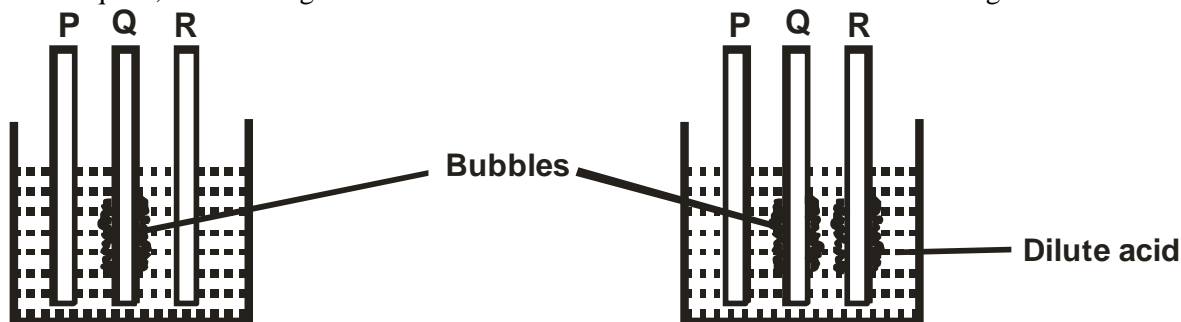

- a) Why is it necessary to clean the rods with sand paper before dipping them into the liquids? (1 marks)
- b) Arrange the three metals in order of their reactivity starting with the most reactive. (1 mark)
11. A solution of chlorine in tetrachloromethane turns colourless when propene gas is bubbled through it.
- a) What type of reaction takes place? (1marks)
- b) Write an equation for the above reaction. (1 mark)
12. With reference to atomic number of one, explain why hydrogen can be placed in either group I and VII of the periodic table. (2 marks)
13. a) Define the term base. (1 mark)
- b) Explain why it is not advisable to use wood ash for cleaning aluminum utensils. (2 marks)
14. A compound has an empirical formula C_3H_6O and a relative formula mass of 116. Determine its molecular formula. (C = 12, O = 16, H = 1) (2 marks)
15. Explain how you would separate mixture of nitrogen and oxygen gases given that their boiling points are $-196^\circ C$ and $-183^\circ C$ respectively. (2 marks)
16. Study the table below and answer the questions that follow.

Alkaline	Formula	Heat of combustion (ΔH_c)KJmol ⁻¹
Methane	CH ₄	-890
Ethane	C ₂ H ₆	-1560
Propane	C ₃ H ₈	-2220
Butane		

- a) Predict the heat of combustion of Butane and write it on the space provided in the table above. (1 mark)
- b) What does the negative sign ΔH_c value indicate about combustion of alkanes? (1 mark)
17. The diagram below represents the extraction of sulphur by Frasch process.

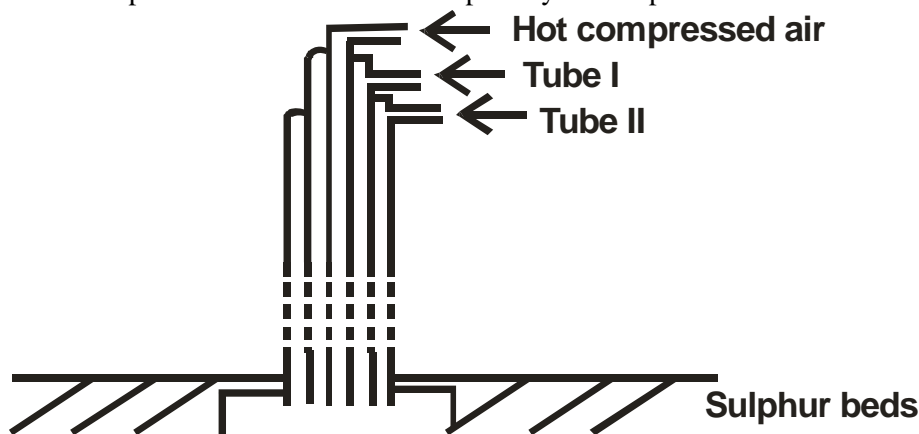

- a) Name the substance that passes through tube I and II. (2 marks)

for more free exam papers visit www.freekcsepastpapers.com

c) What is the purpose of hot compressed air in this process? (1 mark)

18. Study the diagram below and answer the questions that follow.

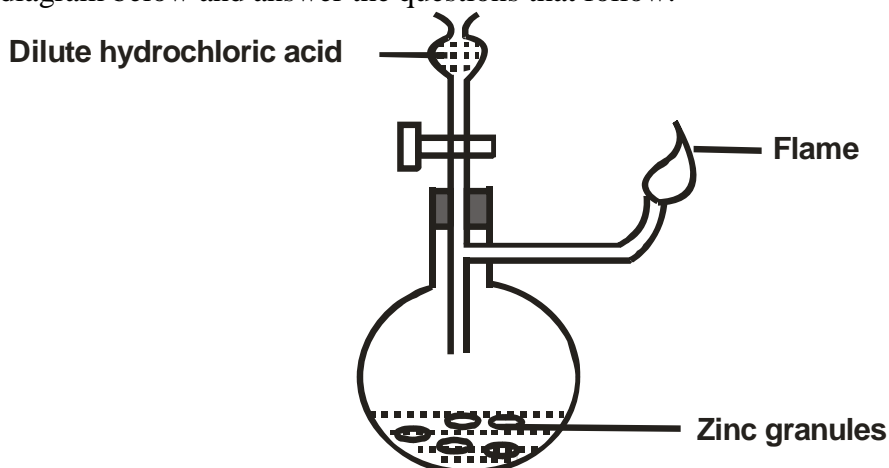

Write an equation for each of the two reactions that take place in the experiment represented by the diagram above. (2 marks)

19. A mixture containing equal volumes of hydrogen gas and carbon (IV) oxide gas was introduced on one end of a tube as shown below.



Which gas would be detected at point C first? Explain. (2 marks)

20. The table below gives three experiments on the reaction of excess sulphuric (VI) acid and 0.5 g of zinc done under different conditions. In each the volume of the gas was recorded at different time interval.

Experiment	Form of zinc	Sulphuric (VI) acid
I	Powder	0.8M
II	Powder	1.0M
III	Granules	0.8M

On the axis below draw and label the three curves that could be obtained from such results. (3 marks)

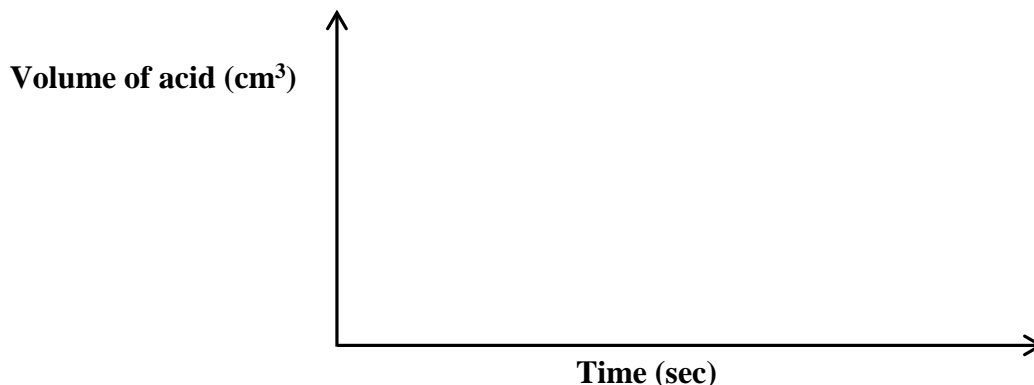

CHEMISTRY PAPER 1,2 & 3

21. The table below shows how solubility of some substances in water varies with temperature

Substance	Change of solubility g/100cm ³ of water with temperature			
	0°C	20°C	40°C	60°C
W	0.334	0.16	0.097	0.0058
X	27.60	34.0	40.0	45.5
Y	35.70	36.0	36.6	37.3

Which of above substances is likely to be a gas? Explain.

(2 marks)

22. Study the chart below and answer the questions that follow.

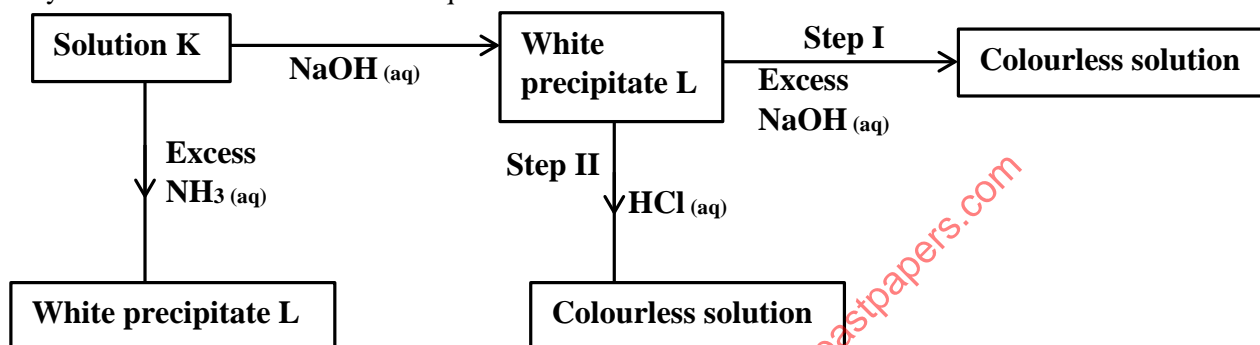

- a) Identify;
- the metal ions in solution K (1 mark)
 - the white precipitate L. (1 mark)
- b) What is the nature of solution K? (1 mark)
23. Explain the following observation. A chloride dissolves in water to form an electrolyte while the same chloride dissolves in methylbenzene to form a non-electrolyte. (2 marks)
24. State what would be observed when dilute hydrochloric acid is added to the products formed from a mixture of iron filings and sulphur. (2 marks)
25. Describe how the following reagents can be used to prepare lead (II)sulphate; solid potassium sulphate, solid lead (II) carbonate, dilute nitric (V) acid and distilled water. (2 marks)
26. Explain why the enthalpy of neutralisation of ethanoic acid with sodium hydroxide is different from that of hydrochloric acid with sodium hydroxide. (2 marks)
27. Give a reason why calcium hydroxide solution is used to detect the presence of carbon (IV) oxide gas while sodium hydroxide solution is NOT. (2 marks)
28. A compound C₂H₂ reacts with hydrogen in presence of nickel catalyst to form another compound C₂H₄. The same compound C₂H₂ reacts with hydrogen to form C₂H₆ in presence of nickel catalyst.
- Draw the structural formula and name the compound C₂H₄. (1 mark)
 - Write the equation for the reaction between C₂H₄ and hydrogen. (1 mark)
29. During the production of hydrogen Iodide, hydrogen reacts with Iodine according to the equation.
- $$\text{H}_{2(g)} + \text{I}_{2(g)} \rightleftharpoons 2 \text{HI}_{(g)} \quad \Delta H +52\text{KJ}$$
- Explain how the following would affect the yield of hydrogen Iodide. (2 marks)
- Increase in temperature
 - Increase in pressure
30. a) Using dots (•) and crosses (x) to represent electrons, draw diagrams to represent the bonding in;
- NH₃
 - NH₄⁺
- b) State why an ammonia molecule (NH₃) can be combined with H⁺ to form NH₄⁺ (atomic numbers N = 7 and H = 1) (1 mark)

CHEMISTRY PAPER 1,2 & 3

31. The table below gives the atomic numbers of elements W, X, Y and Z.
The letters do not represent the actual symbols of the elements.

Element	W	X	Y	Z
Atomic number	9	10	11	12

- a) Which one of the elements is least reactive? (1 mark)
- b) i) Which two elements would react most vigorously with each other? (1 mark)
 ii) Give the formula of the compound formed when elements in b) (i) reacts. (1 mark)
32. When magnesium metal is burnt in air it reacts with both oxygen and nitrogen gases giving a white ash.
- a) Write two equations for the reaction that take place. (2 marks)
- b) When the white ash in (a) above is mixed with water, a gas with a pungent smell is produced. Write an equation for this reaction. (1 mark)
33. In an experiment to separate a mixture of two organic liquids, liquid M (boiling point of 56°C) and liquid N (boiling point of 118°C). A student set up the apparatus as shown below

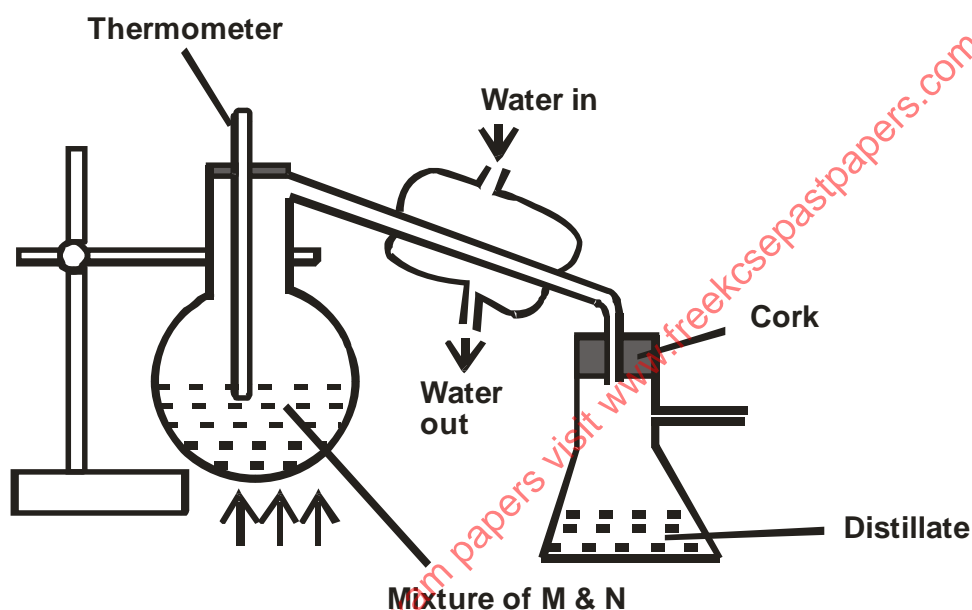

- a) Identify **two** mistakes in the set-up. (2 marks)
- b) What method would the student use to test the purity of the distillates obtained? (1 mark)

MERU
233/2
CHEMISTRY
PAPER 2
(THEORY)

1. The grid below represents part of the periodic table. Study it and answer the questions that follow.
 The letters are not the actual symbols of the elements.

		F	J	H
B	E		L	K
		G		
C				
D				

- i. Select the most reactive non-metal. Explain. (2 marks)
 - ii. Identify an element that can form an amphoteric hydroxide. (1 mark)
 - iii. Which group one element has the lowest first ionization energy? Explain. (2 marks)
 - iv. Name the other group to which element A can be placed and give a reason. (2 marks)
 - v. Compare the atomic size of elements C and G. Explain. (2 marks)
 - vi. Write the electronic configuration of the ion formed by element L and indicate its symbol. (1 mark)
- vii. i) Using dots (•) and crosses (x) to represent electrons, show the bonding in the compound formed between elements B and J. (1 mark)
- ii) Identify an element that is not likely to form any type of bond. Explain. (1 mark)
2. a) Study the reaction scheme below and answer the questions that follow.

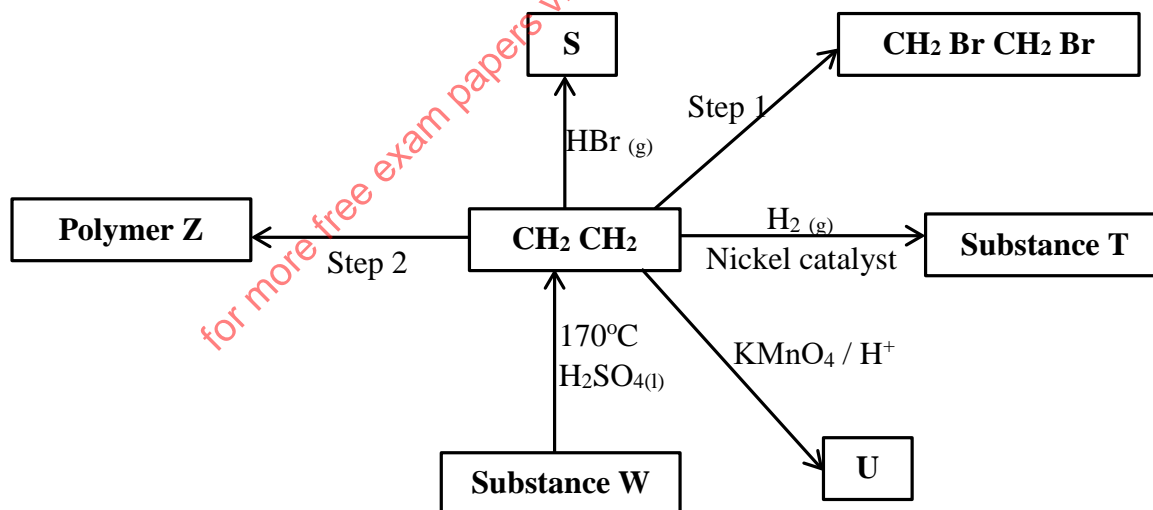

- i) Name the substances; S, T, U and W. (2 marks)
 - ii) Name the reagent for step 1. (1 mark)
 - iii) Draw the polymer Z comprising of three monomers. (1 mark)
 - iv) Name the type of polymerisation on step 2. (1 mark)
- b) Draw the structures of the following compounds.
- i. 2-bromo-3, 3-dimethylpent-1-ene. (1 mark)
 - ii. 1, 2-dichloroethyne. (1 mark)

for more free exam papers visit www.freekcsepastpapers.com

C) Name the following organic compounds.

i.

1 mark

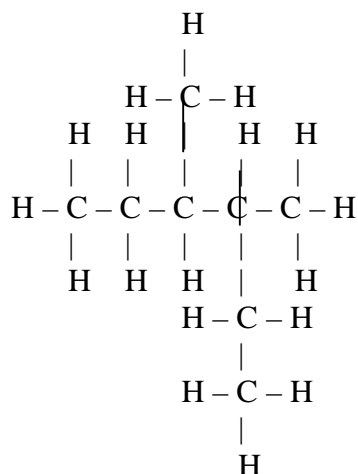

(1

ii. $\text{CH}_3\text{CHCl}(\text{CH}_2)_2\text{C}(\text{CH}_3)_2\text{CH}_2\text{CH}_3$

(1 mark)

d) Draw and name two positional isomers of pentyne.

(2 marks)

3. The flow chart below shows how sulphuric (VI) acid is produced on a large scale.

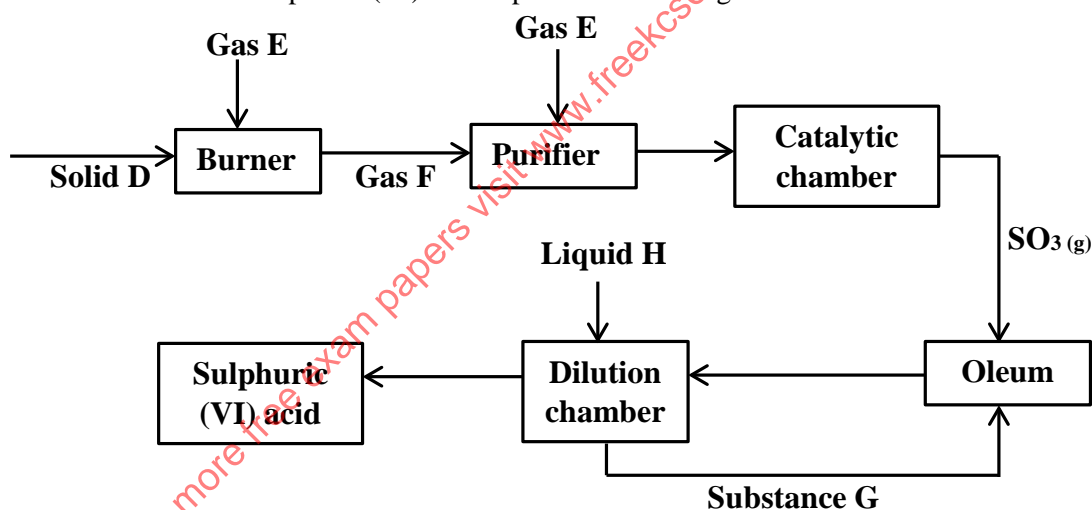

a) Identify the following;

i) Gas E

(½ mark)

ii) Gas F

(½ mark)

iii) Solid D

(½ mark)

iv) Substance G

(½ mark)

v) Liquid H

(½ mark)

b) Name the most preferred catalyst used in the catalytic chamber and give a reason.

(1½ marks)

c) Write an equation for the reaction that forms oleum.

(1 mark)

d) Explain the importance of the purifier.

(2 marks)

e) State **two** ways how pollution is controlled during the process of manufacturing sulphuric (VI) acid.

(2 marks)

f) State **one** industrial application of sulphuric (VI) acid.

(1 mark)

g) What is the name given to the industrial process of manufacturing sulphuric (VI) acid?

(1 mark)

4. The diagram below shows the preparation of Iron (III) chloride salt in the laboratory. Study it and answer the questions that follow.

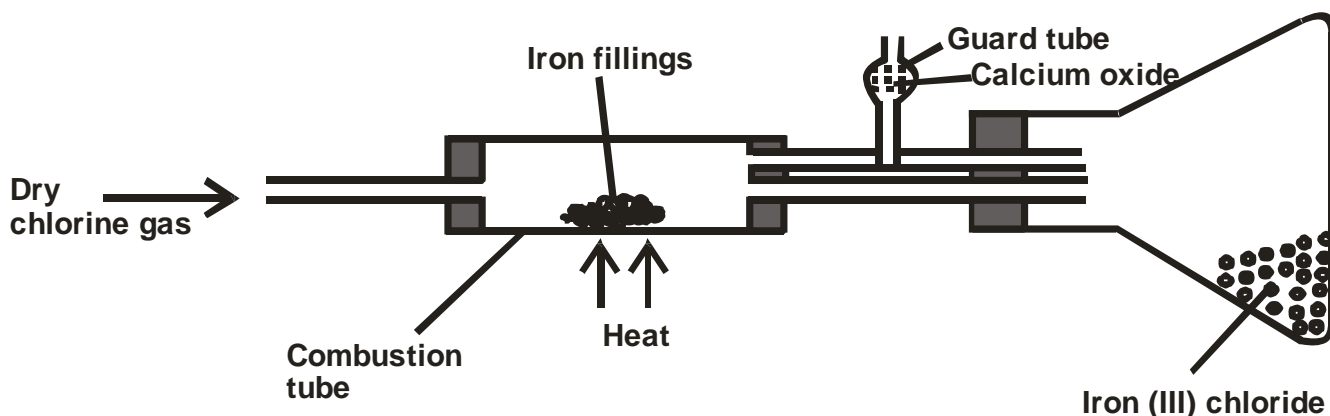

- a) Name the method of preparing Iron (III) chloride salt shown above. (1 mark)
- b) Explain why;
- It is necessary to pass chlorine gas through the apparatus before heating begins. (1 mark)
 - Calcium oxide is more preferred in the guard tube than calcium chloride. (2 marks)
- c) i) What property of Iron (III) chloride makes it possible to be collected as shown in the diagram. (½ mark)
- Name another substance which has the same property as Iron (III) chloride. (½ mark)
- d) Write an equation of the reaction which takes place in the guard tube. (1 mark)
- e) Explain why all dry apparatus and conditions are preferred in the experiment above. (1 mark)
- f) The total mass of Iron (III) chloride formed was found to be 0.5g. Calculate the volume of chlorine gas that reacted with Iron. (Fe = 56, Cl = 35.5, Molar gas volume = 24000cm³) (3 marks)
- g) When hydrogen sulphide gas was passed through a solution of Iron (III) chloride, the following observation were made; red-brown solution changed to green and a yellow solid deposited. Explain this observation. (2 marks)
5. a) State the Hess's law. (1 mark)
- b) Study the equations below and answer the questions that follow.
- $C_{(s)} + O_{2(g)} \longrightarrow CO_{2(g)}$ $\Delta H_1 = - 393 \text{ kJmol}^{-1}$
 - $H_{2(g)} + \frac{1}{2}O_{2(g)} \longrightarrow H_2O_{(l)}$ $\Delta H_2 = - 286 \text{ kJmol}^{-1}$
 - $C_3H_{8(g)} + 5O_{2(g)} \longrightarrow 3CO_{2(g)} + 4H_2O_{(l)}$ $\Delta H_3 = - 2209 \text{ kJmol}^{-1}$
- Name **two** heat changes represented by ΔH_1 (2 marks)
 - Calculate the heat of formation of propane from the equations above, using the energy cycle diagram. (3 marks)
 - Draw the energy level diagram for equation III. (2 marks)
6. a) Candle wax is a compound comprising of two elements. Name them. (2 marks)
- b) The set-up below was used to investigate the burning of a candle. Study it and answer the questions that follow.

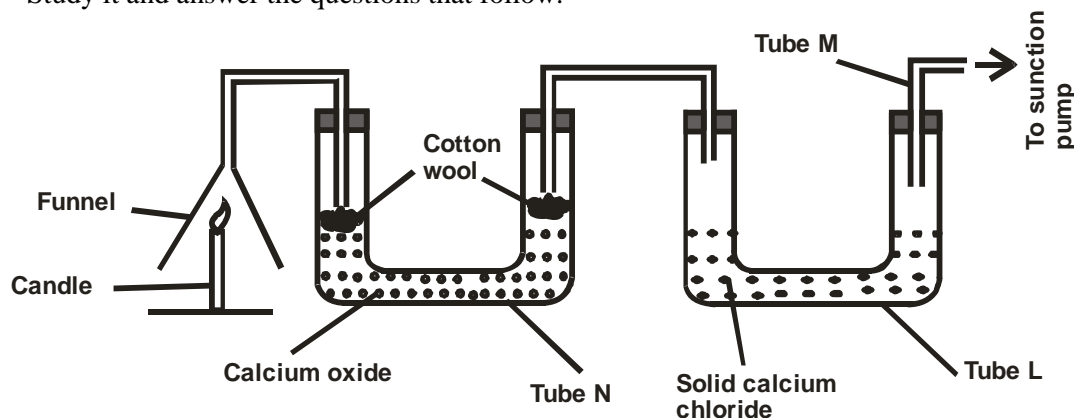

- i. What would happen to the burning candle if the suction pump was turned off. Explain. (2 marks)
 - ii. Explain the purpose of calcium oxide in tube N? (2 marks)
 - iii. What is the role solid calcium chloride in tube L.? (1 mark)
 - iv. Name another substance that could be used in place of calcium oxide in tube N. (1 mark)
 - v. State **two** gases that came out through tube M. (2 marks)
7. A colourless gas was passed over heated lead (II) oxide and the products of the reactions were collected as shown in the diagram below.

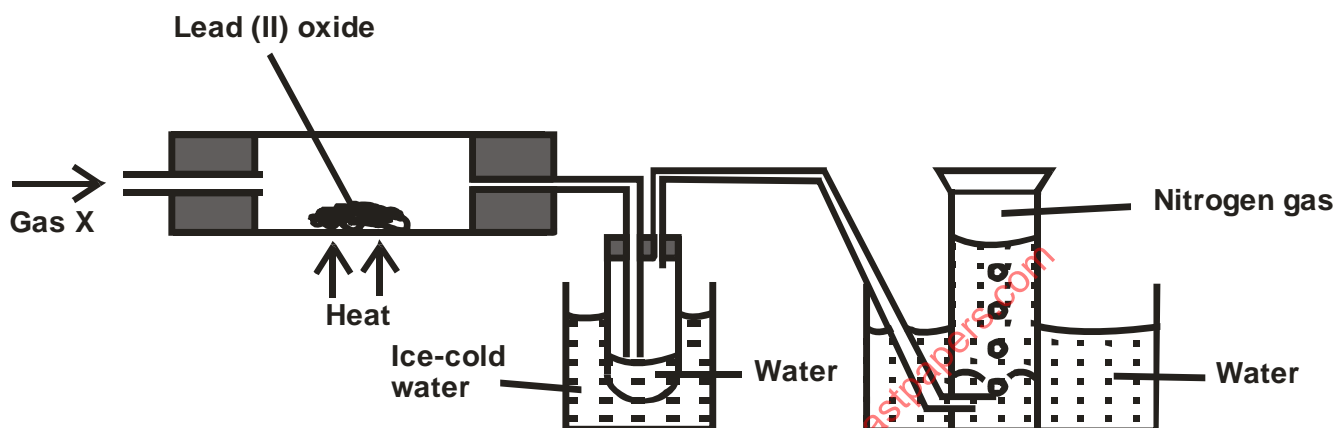

- a) Name gas X. (1 mark)
 - b) State the observation made in the combustion tube. (1 mark)
 - c) What is the purpose of the ice-cold water? (1 mark)
 - d) Write an equation for the reaction that takes place in the combustion tube. (1 mark)
 - e) Why is it possible to collect nitrogen gas as shown in the set up? (1 mark)
 - f) Name the method of obtaining nitrogen gas from air. (1 mark)
8. In an experiment to determine the rate of reaction excess lumps of calcium carbonate were added to 2M hydrochloric acid. The mass of calcium carbonate left was recorded after every 30 seconds.

The results are shown in the table below.

Time (seconds)	0	39	60	90	120	150	180	210
Mass of calcium carbonate left	2.00	1.60	1.30	1.00	0.85	0.80	0.80	0.80

(g)

- a) Write the equation for the reaction that took place. (1 mark)
- b) On the graph paper provided, plot a graph of mass of calcium carbonate (vertical axis) against time. (3 marks)
- c) From the graph;
 - i. Determine the rate of reaction at the 105th second. (2 marks)
 - ii. Why does the curve level off after some time? (1 mark)
- d) On the same graph sketch a curve for the same reaction using 4M hydrochloric acid and level it. (1 mark)
- e) Explain why the experiment above would not be performed with dilute sulphuric (VI) acid. (2 marks)

for more free exam papers visit www.freekcsepastpapers.com

CHEMISTRY PAPER 1,2 & 3
MERU CENTRAL CLUSTER EXAMS
233/3
CHEMISTRY
PAPER 3
(PRACTICAL)

1. You are provided with
- 3.15g of solid A
 - 0.1M Sodium carbonate (solution B)

You are required to determine

- a) The solubility of A at different temperatures
- b) The number of moles of water of crystallisation in solid A.

PROCEDURE 1

- a) Using a burette add 4cm^3 of distilled water to solid A in a boiling tube. Heat the mixture while stirring with the thermometer until all the solid dissolves.
Allow the solution to cool in air while stirring with the thermometer
Note the temperature at which crystals of A appear and record in the table 1 below
- b) Using a burette, add 2cm^3 of distilled water to the content of the boiling tube, warm the mixture while stirring with the thermometer until all the solid dissolves. Allow the solution to cool while stirring and record the temperatures at which crystals appear.
- c) Complete the table 1 by calculating the solubility of solid A at different temperatures
NB: Keep the content of the boiling tube for procedure 2.

Table 1

Volume of water in the boiling tube	Temperature at which crystals appear	Solubility of A g/100g of water
4		
6		
8		
10		
12		

(6 marks)

- I) Plot a graph of solubility of A (vertical) axis against temperature. (3 marks)
- II) Using your graph determine the temperature at which 60g of solid A would dissolve in 100g of water. (1 mark)

PROCEDURE 2

- a) Transfer the content of the boiling tube into a 250ml volumetric flask.
- b) Add distilled water upto the mark and label this solution A.
- c) Fill the burette with solution A.
- d) Using a clean pipette transfer 25ml of solution B into a conical flask, add 2 – 3 drops of methyl orange indicator.
- e) Titrate A against B until the colour changes to pink.
- f) Record your results in the table 2 below.
- g) Repeat C to F two more times.

Table 2

	I	II	II
Final burette reading (cm^3)			

CHEMISTRY PAPER 1,2 & 3

Initial burette reading (cm³)

Volume of solution A used (cm³)

(4 marks)

- a) Determine the average volume of solution A used. (1 mark)
- b) How many moles of sodium carbonate were used? (1 mark)
- c) If 1 mole of A reacts with 1 mole of Na₂CO₃, how many moles of A were used? (1 mark)
- d) Determine the molarity of solution A. (1 mark)
- e) Determine the molar mass of solid A. (1 mark)
- f) If the formula of A is (COOH)₂.XH₂O. Determine the value of X. (C = 12, O = 16, H = 1) (2 marks)

2. You are provided with solid C. Use it to carry the tests outlined below.

Dissolve the whole of C into 10cm³ of distilled water and divide the resulting solution into 5 portions.

a) To the first portion add dilute hydrochloric acid.

Observations	Inferences
(1 mark)	(2 marks)

b) To the second portion add sodium hydroxide dropwise until in excess.

Observations	Inferences
(1 mark)	(1 mark)

c) To the third portion add sodium sulphate solution.

Observations	Inferences
(1 mark)	(1 mark)

d) To the fourth portion add Lead (II) nitrate solution.

Observations	Inferences
(1 mark)	(1 mark)

e) To the last portion add Barium Nitrate solution.

Observations	Inferences
(1 mark)	(1 mark)

3. You are provided with solid D. Use it to carry the tests outlined below.

a) Ignite $\frac{1}{3}$ of solid D in a metallic spatula using a non-luminous flame.

Observations	Inferences
(1 mark)	(1 mark)

b) To the remaining solid D in the test tube, add 6cm³ of distilled water and divide the resulting mixture into 3 portions.

i) To the first portion add solid sodium hydrogen carbonate.

CHEMISTRY PAPER 1,2 & 3

Observations	Inferences
(1 mark)	(1 mark)

for more free exam papers visit www.freekcsepastpapers.com

ii) To the second portion add acidified KMnO_4 (potassium manganate (VII)).

Observations	Inferences
(1 mark)	(1 mark)

iii) To the last portion add bromine water.

Observations	Inferences
(1 mark)	(1 mark)

LANGATA/DAGORETTI C LUSTER

233/1

CHEMISTRY

(THEORY)

PAPER 1

1. A Student in form four placed a thermometer in molten naphthalene at 85°C and recorded the temperature and time until the naphthalene solidified. From the values obtained, the figure below was drawn.



- (a) What name is given to such a figure?..... (1mk)
 - (b) Which part of the figure represents the change of state of naphthalene?..... (1mk)
 - (c) In terms of kinetic theory. Explain what happens to molecules along AB. (1mk)
2. In a certain reaction, 18.7cm^3 of a dibasic acid H_2X required 25cm^3 of 0.1M NaOH for complete neutralization.
- (a) How many moles of Sodium hydroxide are contained in 25cm^3 ? (1mk)
 - (b) Calculate the molarity of the dibasic acid. (2mks)
3. Study the flow chart below and answer the questions that follow.

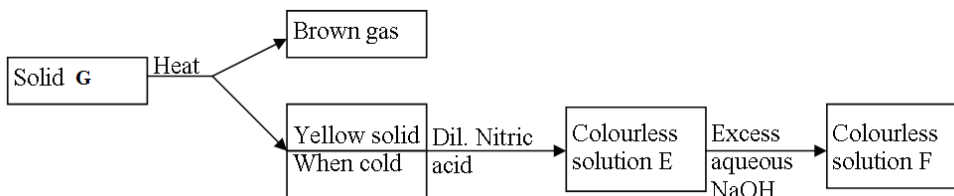

- (a) Identify solid G (1mk)
 - (b) Write a balanced chemical equation between the yellow solid and dilute nitric acid. (1mk)
 - (c) Write the formula of the complex ion in solution F (1mk)
4. Explain this observation:

CHEMISTRY PAPER 1,2 & 3

When hydrogen chloride gas is dissolved in water, the solution conducts electricity while a solution of hydrogen chloride gas in methyl benzene does not conduct electricity. (2mks)

5. Matter exists in three states which can be related as shown in the diagram below.

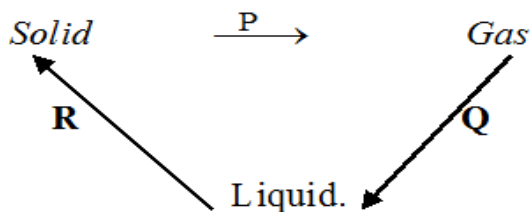

- (a) Name processes: P: (1mark)
 R: (1mark)
- (b) Explain whether process Q is exothermic or endothermic (1mark)
6. (a) What is meant by allotropy? (1mark)
 (b) Name two allotropes of carbon. (1mark)
 (c) Give one use of charcoal in the sugar refinery industry. (1mk)
7. (a) State Graham's Law of Diffusion (1mk)
 (b) A given volume of ozone (O₃) diffused from a certain apparatus in 96 seconds. Calculate the time taken by an equal volume of carbon(IV) oxide to diffuse under the same conditions. (C=12,O=16) (2mks)
8. (a) Name two ores from which copper is extracted. (1mk)
 (b) During the extraction of copper metal the ore is subjected to froth floatation. Give a reason why this process is necessary. (1mk)
 (c) One of the alloys of copper is brass. State its two uses. (1mk)
9. Draw a dot (●) and cross (X) diagram to show bonding in sulphur (IV) oxide (1mk)
10. A form one class carried out an experiment to determine the active part of air. The diagram below shows the set-up of the experiment and also the observation made.

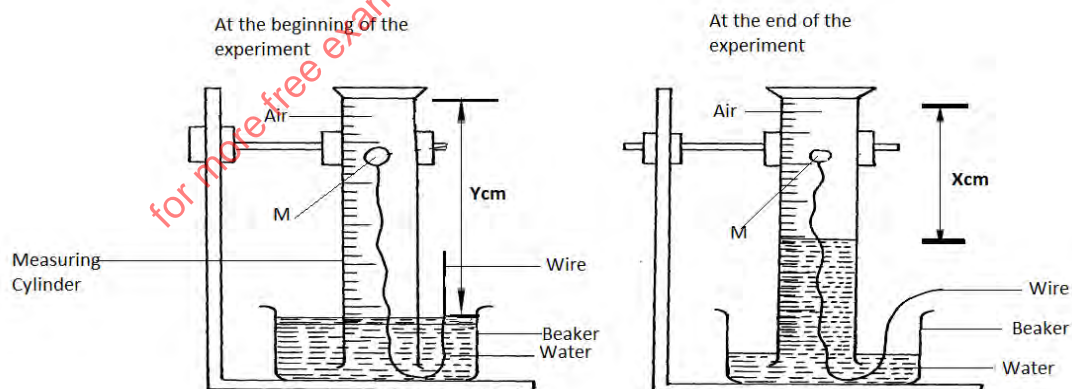

- (a) Identify substance M (1mk)
 (b) State two reasons for the suitability of substance M for this experiment (1mk)
 (c) Write the equation for the reaction of substance M and the active part of air (1mk)
11. (a) Complete the following equation (1mk)

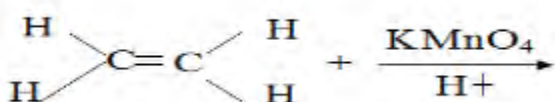

CHEMISTRY PAPER 1,2 & 3

(b) Name the homologous series to which the following compounds belong?

(i) CH_3CCH (1mk)

(ii) $\text{CH}_3\text{CH}_2\text{OOCCH}_3$ (1mk)

12. The table below shows the pH values of solutions J to N

Solution	J	K	L	M	N
pH	5	13	2	10	7

(a) Which solution contains the largest concentration of hydroxides ions? (1mk)

(b) Which solution is likely to be a solution of acetic acid? (1mk)

for more free exam papers visit www.freekcepastpapers.com

13. The scheme below was used to prepare a cleansing agent. Study it and answer the questions that follow.

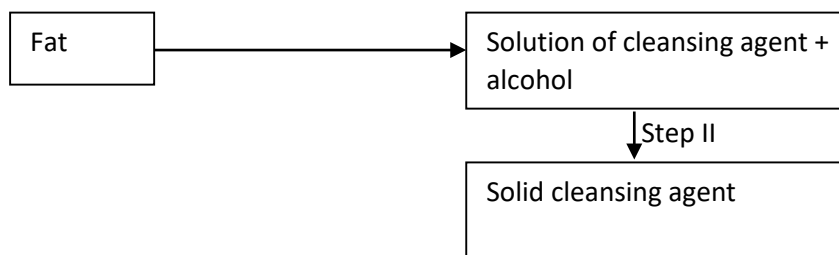

- (i) What name is given to the type of cleansing agent prepared by the method shown in the scheme? (1mk)
- (ii) Name one chemical substance added in step II (1mk)
- (iii) What is the purpose of adding the chemical substance named in (ii) above. (1mk)
14. a) Define half – life of radio isotopes. (1mk)
- b) Z grammes of a radioactive isotope take 100 days to decay to 20gms. If the half – life of the element is 25 days. **Calculate** the initial mass of Z of the radio- isotope. (2mks)
15. Magnesium was burnt in air forming a white residue T. When put in a boiling tube with water effervescence was noticed and colourless gas D with a characteristic pungent smell was evolved. The gas turned a wet red litmus paper blue.
- (a) **Identify**
- (i) Residue T (1mk)
- (ii) Gas D..... (1mk)
- (b) **Write** an equation for liberation of gas D. (1mk)
16. Explain why the bleaching action of chlorine is permanent while bleaching by sulphur (IV) oxide is temporary. (2marks)
17. Explain how you would separate a mixture of nitrogen and oxygen gases given that their boiling points are -196°C and -183°C respectively. (3mks)
18. Hydrazine gas, shown below, burns in oxygen to form nitrogen gas and steam.



- (a) Write an equation for the reaction (1mk)
- (b) Using the bond energies given below, calculate the enthalpy change for the reaction in (a) above (2mks)

Bond	Bond energy KJ per mole
$\text{N} \equiv \text{N}$	944
$\text{N}=\text{N}$	163
$\text{N}-\text{H}$	388
$\text{O}=\text{O}$	496
$\text{H}-\text{O}$	463

19 Using reagents provided only, explain how you could prepare solid Zinc carbonate. (2mks)

- Zinc powder
- Nitric (V) acid (dilute)
- Water
- Solid sodium carbonate

20 The apparatus below was set up to show the catalytic oxidation of ammonia.

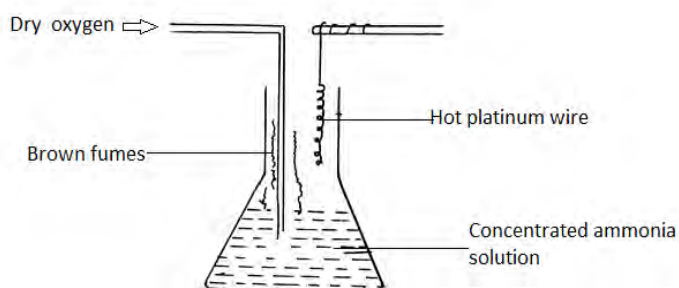

- (a) Identify the brown fumes observed at the mouth of the conical flask. (1mk)
- (b) Write down the equations of the reactions representing
- (i) Catalytic oxidation of ammonia (1mk)
- (ii) The formation of the brown fumes. (1mk)

21 Consider the chromatogram below.

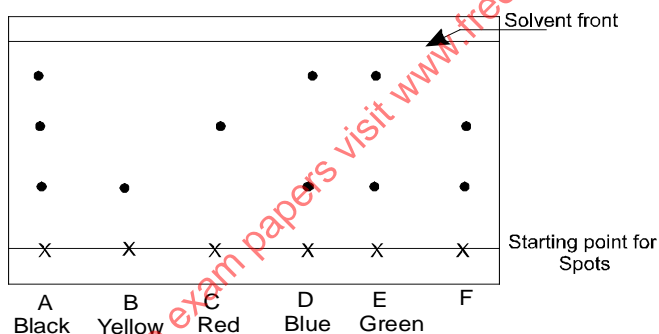

A piece of chromatogram paper was spotted with colour inks obtained from pens labeled A to F. The diagram above shows the spots after the chromatograph was developed.

- (a) Which two pens contained the same pigment? (1mk)
- (b) According to the chromatogram which pigments are present in the inks of the pen number F (1mk)
- (c) Describe how one could get a sample of yellow pigment (1mk)

22. Consider the following reaction at equilibrium.

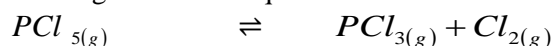

Complete the table below to show the effect of different factors on the position of equilibrium (3mks)

Factor	Effect on the equilibrium position
(i) Decrease pressure	
(ii) Removing chlorine	
(iii) Adding Helium gas to mixture	

23. A student investigated the effect of an electric current by passing it through some substances. The student used inert electrodes and connected a bulb to the circuit. The table below shows the substances used and their states.

CHEMISTRY PAPER 1,2 & 3

Experiment	Substance	State
1	Potassium carbonate	Solid
2	Copper (II) sulphate	Solution
3	Sugar	Solution
4	Lead (II) iodide	Molten

- (a) In which experiments did the bulb not light? (1mk)
 (b) Explain your answer in (a) above. (2mks)
24. Give a reason why the formula mass of NO_2 is sometimes 92 instead of 46. (1mk)
25. A compound contains only carbon, hydrogen and oxygen. Combustion of 1.068g of the compound produces 1.601g of carbon (IV) oxide and 0.437g of water. The molar mass of the compound is 176.1g/mol. What is the empirical and molecular formulae of the compound? (2mks)
26. (a) A sample of water in a beaker was found to boil at 102°C at 1 atmospheric pressure. Assume that the thermometer was not faulty explain this observation (1mk)
 (b) Study the information in the table below and answer the questions that follow.

Salt	Solubility (g/100g water)	
	At 40°C	At 60°C
CuSO_4	28	38
$\text{Pb}(\text{NO}_3)_2$	79	98

- A mixture containing 35g of CuSO_4 and 78g of $\text{Pb}(\text{NO}_3)_2$ in 100g of water at 60°C was cooled to 40°C
- (i) Which salt crystallized out? Give a reason. (1mk)
 (ii) Calculate the mass of the salt that crystallized out. (1mk)
27. A student was asked to determine the percentage of zinc metal in a mixture of zinc metal and zinc oxide. He reacted the mixture with excess hydrochloric acid and accurately collected the gas evolved, which was then used to calculate the amount of zinc in the mixture.
- (a) Name the gas that was evolved..... (1 mark)
 (b) Apart from the reaction liberating the gas write a balanced equation for the other reaction that took place. (1 mark)
 (c) Why would dilute nitric acid not be suitable for this reaction? (1 mark)
28. Below is part of the flow diagram of the contact process.

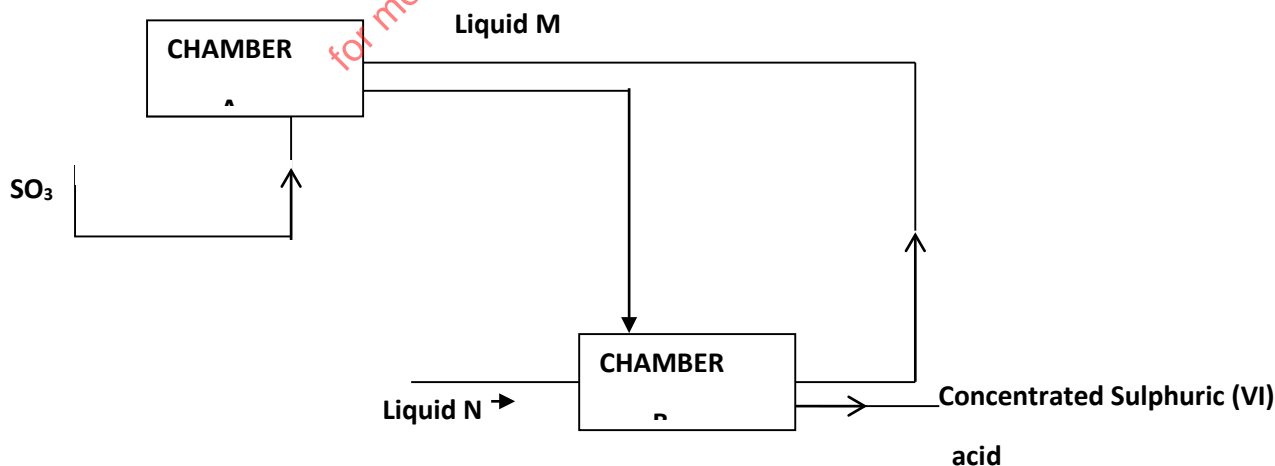

- (a) Identify (i) Liquid M..... (1mk)
(ii) Liquid N..... (1mk)
- (b) Write the equation for the reaction taking place in chamber B. (1mk)
29. Chlorine gas dissolved in distilled water to form chlorine water
(a) Name the compounds present in the chlorine water. (1mk)
(b) What would be observed if blue litmus paper is dipped in chlorine water? Explain. (2mks)
30. A fixed mass of gas occupies 105cm^3 at -14°C and 650mmHg pressure. At what temperature will it have a volume of 15cm^3 if the pressure is adjusted to 690 mmHg pressure (2mks)

LANGATA/DAGORETTI CLUSTER

233/2

CHEMISTRY**Paper 2****THEORY**

1. The grid below represents part of the periodic table. Study it and answer the questions that follow. The letters do not represent the actual symbols of the element.

				N		S		
K	Q		O			P	F	M
	R							

- a) What name is given to the group of elements to which Q and R belong? (1 mark)
- b) Write the formula of the compound formed when Q and P combine. (1 mark)
- c) Name the type of bond formed in (b) above. (1 mark)
- d) How does the atomic radii of O and P compare? Give a reason. (2 marks)
- e) Draw a dot (.) and cross (x) diagram for the compound formed between N and F. (1 mark)
- f) Explain how you would obtain a pure sample of the carbonate of K from its mixture with Lead carbonate powder. (2 marks)
- g) Give one use of element M. (1 mark)
- h) The melting point of M is 189°C lower than that of F -102°C . Explain this difference in their melting points. (2 marks)
2. The list below shows the formulae of some organic compounds. Use letters T1 to T6 to answer the questions that follow.
- T₁ – $\text{CH}_3\text{CH}_2\text{CH}_2\text{CH}_2\text{CH}_3$
- T₂ – $\text{CH}_3\text{CH}_2\text{CH}_2\text{COOC}_2\text{H}_5$
- T₃ – $\text{CH}_3\text{CH}_2\text{CH}_2\text{CH}_2\text{OH}$
- T₄ – $\text{CH}_3\text{CH}_2\text{CH}_2\text{COOH}$
- T₅ – $\text{CH}_3\text{CH}_2\text{CHCH}_2$
- T₆ – CH_3CCCH_3
- (a) Select two compounds which:
(i) Are not hydrocarbons (1mk)

- (ii) Would decolourise both bromine water and acidified potassium manganite (VII) (1mk)
 (iii) Would produce hydrogen gas when reacted with potassium metal (1mk)
 (b) Select a compound which would produce bubbles of a gas when reacted with sodium carbonate. (1mk)
 (c) (i) Identify the compound that is likely to undergo polymerization. Give a reason for your answer. Using two molecules show how polymerization occurs.
- I. Compound (1mk)
 II. Reasons (1mk)
 III. Polymerization (1mk)

(iv) Name the process by which compound T₂ is formed and identify the compounds that were used to form it.

- I. Process (1mk)
 II. Compounds (1mk)

(d) Compound T₃ can be converted to T₄ as shown by the equation below:

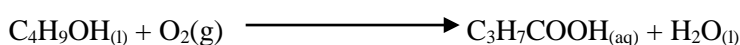

Given the following information:

$$\Delta H_c \text{ for } \text{C}_4\text{H}_9\text{OH} = -4910 \text{ kJ/mol}$$

$$\Delta H_c \text{ for } \text{C}_3\text{H}_7\text{COOH} = -4090 \text{ kJ/mol}$$

Determine the heat change for the reaction above.

(2mks)

3. a) What is meant by the term molar enthalpy of combustion? (1mks)

b) The enthalpies of combustion of carbon, hydrogen and ethanol are given below.



- i) Draw an energy cycle diagram that links the enthalpy of formation of ethanol to enthalpies of combustion of Carbon, hydrogen and ethanol. (3 marks)
 ii) Determine the enthalpy of formation of ethanol (1 marks)
 c. An experiment was carried out where different volumes of dilute nitric acid (v) acid and aqueous potassium hydroxide both at 25°C were mixed and stirred with a thermometer.

The highest temperature reached by each mixture was recorded in the table below.

Volume of nitric (V) acid (cm ³)	4	8	12	16	20	24	28	32	36
Volume of potassium hydroxide cm ³	36	32	28	24	20	16	12	8	4
Highest temperature of mixture	19.8	22.2	24.6	27.0	27.0	25.0	23.0	21.0	19.0

Plot a graph of highest temperature (vertical axis) against volume of nitric acid. (horizontal axis) 3mks

Using your graph, determine the;

CHEMISTRY PAPER 1,2 & 3

- i. highest temperature reached (½ marks)
 ii. The volume of the acid that reacted when the highest temperature is reached. (½ marks)
 iii. The amount of heat liberated during the neutralization process
 (Specific heat capacity is $4.2\text{Jg}^{-1}\text{K}^{-1}$ and the density of solution is 1.0gcm^{-3}) (2 marks)
- d) The molar enthalpies of neutralization for dilute hydrochloric acid and dilute nitric (v) acid are -55KJmol^{-1} . while that of ethanoic acid is -52.2kJ/mol . Explain this observation. (2 mks)

4. Experiment was set as shown below.

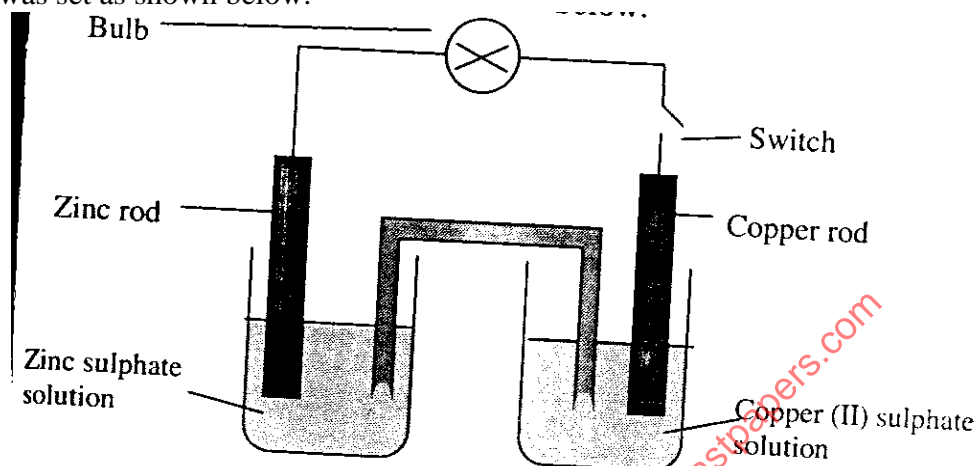

- (a) What is observed on the bulb when the switch is closed? (1mk)
 (b) Which electrode will be cathode? (1mk)
 (c) Write down the half-cell equations for:
 i. Copper electrode. (1mk)
 ii. Zinc electrode. (1mk)
 (d) Write the overall ionic equation for the electrochemical cell. (1mk)

(e) The table below shows the electrode potentials.



What is the value of the voltage of the cell? (2mks)

- (f) The switch is kept closed. State and explain the observation expected after sometime on the
 (i) The zinc rod. (2mks)
 (ii) Copper (II) Sulphate solution. (2mks)

5. The chart below represents the extraction of iron and some of its uses.

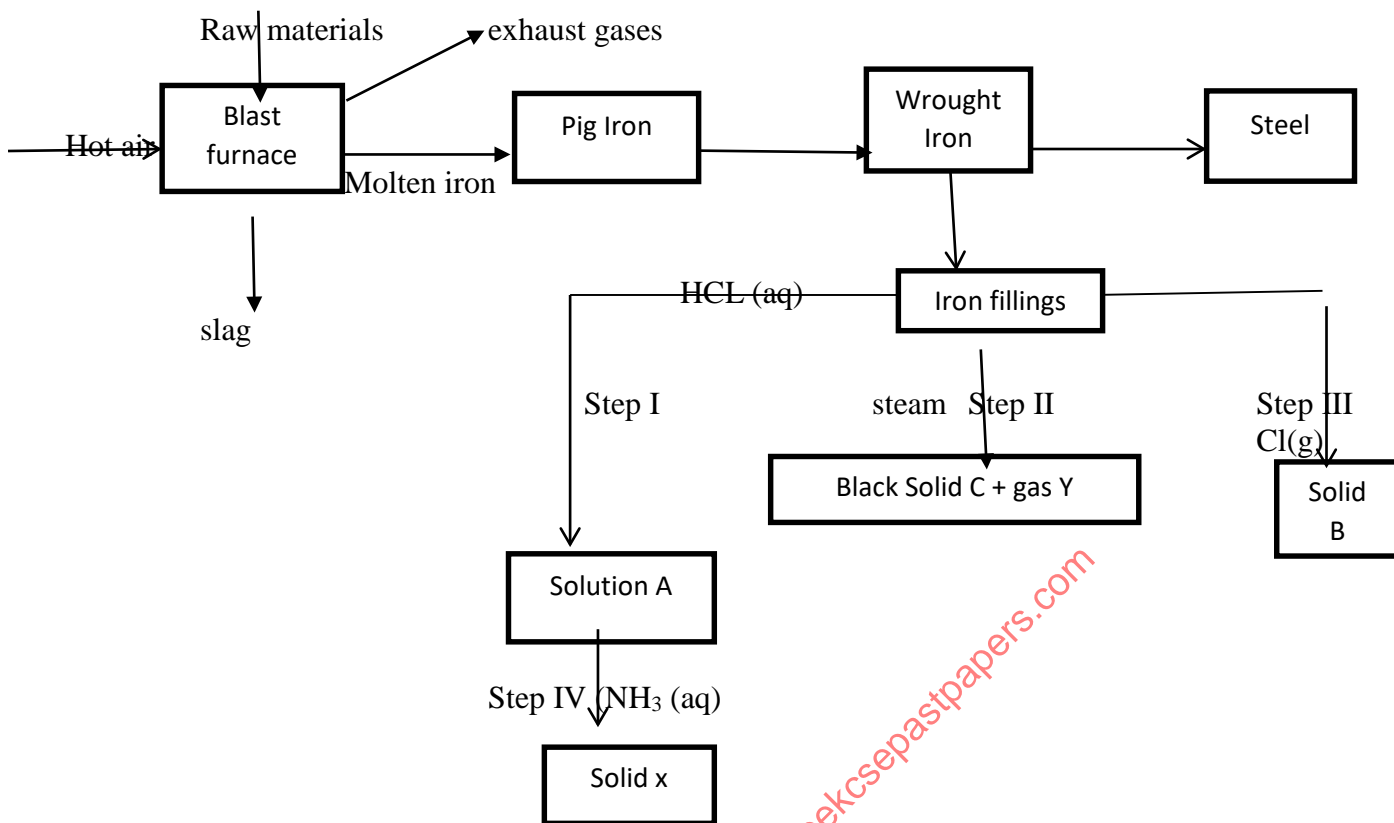

- (a) Name the raw materials fed into the blast furnace. (2mks)
- (b) Name 3 exhaust gases emitted from the blast furnace. (1½mks)
- (c) (i) Why is it necessary to convert pig iron into wrought iron? (1mk)
 (ii) State one commercial use of iron. (1mk)
- (d) Name substances A, B, C, X & Y (2½mks)
- (e) Write equations for reactions in steps
- II (2mks)
 - III (1mk)
 - Write an ionic equation for the reaction in step I. (2mks)
 - What observations are made in steps?
 I
 I

6. Study the flow chart below and answer the questions that follow.

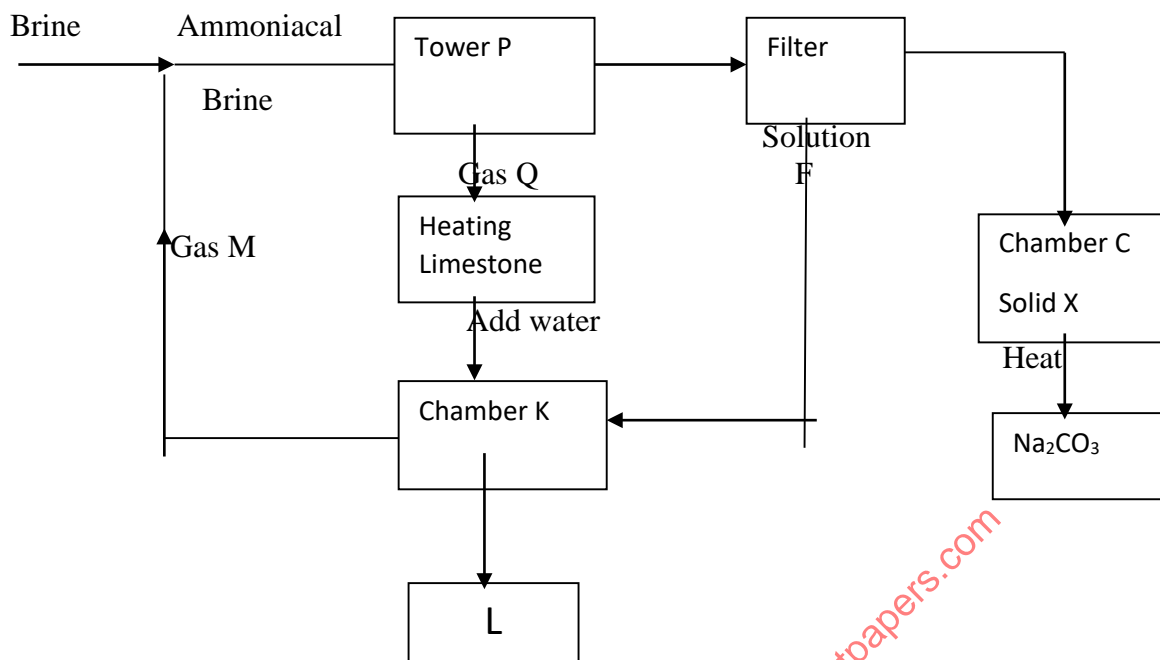

- Name Gas M (1 mark)
 - Name solution F and solid X (1 mark)
 - Name the product L formed and give one of its uses (2 mark)
 - Write equation of the reaction in the;
 - tower P -
 - chamber K -
 - Name two raw materials required in the manufacture of Sodium carbonate (2 marks)
 - Write an equation of the reaction when solid x is heated. (1 mark)
7. The table below shows the volume of nitrogen (IV) Oxide produced when different volumes of 1M Nitric (V) acid – were each reacted with 4.14g of lead at room temperature.

Volume of 1 M Nitric (V) acid (cm ³)	Volume of Nitrogen (IV) oxide gas (cm ³)
10	120
30	360
50	600
70	840
90	960
110	960

- Explain how the rate of the reaction between lead and nitric (V) acid would be affected if the temperature of the reaction mixture was lowered. (1mks)
- On the grid provided below plot a graph of the volume of the gas produced (vertical axis) against volume of acid. (3mks)
- Using the graph, determine the volume of
 - Nitrogen (IV) oxide produced when 60cm³ of 1M Nitric (V) acid were reacted with 4.14g of lead. (1mk)
 - 1M Nitric (V) acid which would react completely with 4.14g of lead. (1mk)
- Using the answer in d(ii)above, determine
 - The volume of 1M Nitric (V) acid that would react completely with one mole of lead. (Pb = 207). (2mks)

CHEMISTRY PAPER 1,2 & 3

- (e) Calculate the number of moles of
- (i) 1M Nitric (IV) acid reacted with one mole of lead. (1mk)
 - (ii) Nitrogen (IV) oxide produced when one mole of lead were reacted with excess nitric acid. (Molar gas volume is 24000cm^3).
- (f) Using the answers obtained in e(i) and e(ii) above; write the equation for the reaction between lead and nitric (V) acid given that one mole of lead (II) nitrate and two moles of water were produced (1mk)
- (g) Give a reason why nitric (V) acid is stored in dark bottles. (1mk)

LANGATA/DAGORETTI CLUSTER
233/3 CHEMISTRY
PAPER 3
END OF TERM II 2020

(CONFIDENTIAL)

In addition to the apparatus found in the laboratory each candidate will require the following

- About 0.5g of solid F
- About 1g of solid G
- 6 clean test-tubes
- Universal indicator solution and a pH chart
- Ethanol supplied with a dropper
- Clean dry metallic spatula
- 1 boiling tube
- Distilled water
- Solution J, about 130cm^3
- Solution Q, about 160cm^3
- Solution R, about 30cm^3
- Screened methyl orange indicator
- Methyl orange indicator
- 100ml measuring cylinder
- Filter paper
- Means of labeling
- Solid P
- Thermometer
- 100ml beaker

Access to the following;

- ❖ Ethanol supplied with a dropper
- ❖ Concentrated sulphuric (VI) acid supplied with a dropper bottle
- ❖ Acidified Potassium dichromate (VI) solution
- ❖ Acidified Potassium Manganate (VII) solution.
- ❖ 2M $\text{Ba}(\text{NO}_3)_2$ solution.
- ❖ 2M NaOH solution.
- ❖ 2M HCl acid.
- ❖ Source of heat.

Preparation

- ✓ Solution J is 0.12M HCL, prepared by adding about 800cm^3 of distilled water to 4.05cm^3 of concentrated HCL of density 1.08gcm^{-3} and making it to one litre of solution.
- ✓ Solution Q is prepared by dissolving 5.3g of anhydrous sodium carbonate in enough distilled water and making up to one litre of solution.
- ✓ Solution R is prepared by dissolving 15.75g of hydrated barium hydroxide in enough distilled water and top up to one

CHEMISTRY PAPER 1,2 & 3

litre of solution.

- ✓ Solid P is 2.0g of oxalic acid weighed accurately and supplied in a stoppered container
- ✓ Solid F is maleic acid
- ✓ Solid G is sodium sulphite

233/3

CHEMISTRY

Paper 3

(PRACTICAL)

1. You are provided with:

- A monobasic acid HA, solution J.
- Sodium carbonate solution, solution Q, containing 1.325g in 250cm³ of solution.
- Solution R, containing 15.75g of M(OH).8H₂O per litre.
- Screened methyl orange indicator.

You are required to:

- Standardize solution J.
- Determine the relative atomic mass of element M in M (OH)₂. 8H₂O.

Procedure 1

Fill the burette with solution J. Pipette 25cm³ of solution Q into a clean 250ml conical flask and add 2 – 3 drops of screened methyl orange indicator. Titrate this solution with the solution in the burette and record your results in table 1 below. Repeat this procedure and complete the table. **Retain solution J in the burette for use in procedure II.**

Table 1

Titre	I	II	III
Final burette reading (cm ³)			
Initial burette reading (cm ³)			
Volume of J used (cm ³)			

(4 marks)

- a) Calculate the average volume of solution J used. (1 mark)
- b) Determine the concentration of solution Q in moles per litre (Na=23, C=12, O=16) (1 mark)
- c) (i) Determine the number of moles of the monobasic acid solution, HA, that are in the averaged value calculated in (b) above. (1 mark)
- (ii) Determine the concentration of solution J in moles per litre. (1 mark)

Procedure 2

- Using a 25cm³ measuring cylinder, transfer 25cm³ of solution R into a clean 250ml conical flask. Using a 100ml measuring cylinder, transfer 75cm³ of solution Q into the flask with solution R. Boil the mixture for about 5 minutes. After cooling filter into a conical flask and transfer the filtrate into a clean 100ml measuring cylinder and add distilled water to make exactly 100cm³ of solution. Label this solution as solution S.
- Pipette 25cm³ of solution S into a conical flask and titrate it with solution J using 2 drops of screened methyl orange indicator. Record your results in table 2 below. Repeat this to complete the table.

Table 2

Titre	I	II	III
Final burette reading (cm ³)			
Initial burette reading (cm ³)			
Volume of J used (cm ³)			

- d) Calculate the average volume of solution J used. (4 marks)
- e) Determine the number of moles of: (1 mark)
- The monobasic acid, HA, in the average volume. (1 mark)
 - Sodium carbonate in 25cm³ of solution S. (1 mark)
 - Sodium carbonate in 75cm³ of solution S. (1 mark)
 - Sodium carbonate in the original 75cm³ of solution S. (1 mark)
 - Sodium carbonate that reacted with solution R. (1 mark)
 - M(OH)₂·8H₂O in 25cm³ of solution R. (1 mark)
- (1 mole of M(OH)₂·8H₂O reacts with one mole of sodium carbonate)
- f) Determine
- the concentration of solution R in moles per litre. (1 mark)
 - the relative formula mass of M(OH)₂·8H₂O. (1 mark)
 - the relative atomic mass of M (O=16.0, H=1.0) (1 mark)

2. You are provided with:
Solid P, 2.0 g of a dibasic acid H₂X.
You are required to determine the molar heat of solution of solid P.

PROCEDURE

Place 30cm³ of distilled water into a 100ml beaker. Measure the initial temperature of the water and record it in the table below. Add all the solid P at once and stir the mixture carefully with the thermometer until all the solid dissolves. Measure the final temperature reached and record it in table.

Final temperature (°C)

Initial temperature (°C)

- Determine the change in temperature, ΔT. (3 marks)
 - Calculate the: (1 mark)
 - heat change when H₂X dissolves in water. (Assume the heat capacity of the solution is 4.2 Jg⁻¹°C⁻¹ and density is 1g/cm³) (2 marks)
 - Number of moles of the acid that were used. (Relative formula mass of H₂X is 126) (1 mark)
 - Molar heat of solution, ΔH, of the acid H₂X. (1 mark)
3. You are provided with solid G. Place all solid G in a boiling tube. Add distilled water and shake. Divide the resulting solution into three portions.

Inferences

(½ mk)

Observations

(½ mk)

CHEMISTRY PAPER 1,2 & 3

i) To the first portion add drops of 2M sodium hydroxide.

Inferences	Observations
(½ mk)	(½ mk)

ii) To the second portion dip a metallic spatula in the solution and burn it directly on a non-luminous flame.

Inferences	Observations
(½ mk)	(½ mk)

iii) To the third portion add three drops of barium nitrate solution followed by 2cm³ of 2M hydrochloric acid.

Inferences	Observations
(½ mk)	(½ mk)

iv) To the fourth portion add three drops of acidified potassium dichromate (VI) solution.

Inferences	Observations
(½ mk)	(½ mk)

b) You are provided with solid **F**. Carry out the tests below and record your observations and inferences in the spaces provided

(i) Using a metallic spatula, heat half of solid **F** in a non-luminous bunsen burner flame .

Inferences	Observations
(½ mk)	(½ mk)

(ii) Put a half spatula endful of solid **F** into a boiling tube. Add about 10cm³ of distilled water and shake.

Inferences	Observations
(½ mk)	(½ mk)

Divide the resulting solution from a(ii) above into two portions

(iii) To the first portion, 2-3 drops of universal indicator and determine its pH.

Inferences	Observations
(½ mk)	(½ mk)

(iv) To the second portion, add two drop of acidified potassium Manganate (VII) solution and shake.

Inferences	Observations
(½ mk)	(½ mk)

CHEMISTRY PAPER 1,2 & 3

(c) Put half spatula endful of solid **F** into a boiling tube and add 5 drops of ethanol followed by 2 drops of concentrated sulphuric (VI) acid. warm the mixture.

Inferences

(½ mk)

Observations

(½ mk)

for more free exam papers visit www.freekcsepastpapers.com

LANJET F4 JOINT EXAMINATION – 2020*Kenya Certificate of Secondary Education*

233/1

CHEMISTRY**PAPER 1**

- State the observations made when a piece of sodium metal is dropped into a beaker containing water. (2mks)
- During a class experiment, students passed gas X over heated copper metal, the metal changed its colour to black.
 - Identify gas X. (1mk)
 - Name the black substance formed. (1mk)
- Aluminium is extracted from its ore by electrolysis.
 - Name the main ore of Aluminium. (1mk)
 - The Aluminium ore in (a) above has a very high melting point.(2015⁰C),though it is electrolyzed at a lower temperature of about 900⁰ C. Explain how the low temperature is achieved. (1mk)
 - In the above process, graphite electrodes are used. What is the disadvantage of using this kind of electrodes (1mk)
- A student added 50cm³ of 1.0M aqueous Sulphuric (VI) acid to 50cm³ of 2.0M Potassium Hydroxide and the temperature of the resulting solution rose by 4⁰ C.
 - Define the term Molar heat of neutralization. (1mk)
 - Calculate the molar heat of neutralization (C=4.2KJKg⁻¹ K⁻¹ ,Density of solution=1g/cm³) (2mks)
- Use the table below to answer the question that follow:

Element	Atomic number
A	11
B	13
C	14
D	17
E	19

- Write an equation for the reaction between element A and water. (1mk)
 - Explain the trend of atomic radii between elements A and D. (2mks)
- In terms of structure and bonding, explain why graphite is used as a lubricant. (2mks)
 - State the Boyles Law. (1mk)
 - A given mass of the gas occupies 20cm³ at 25⁰ C and 670mmHg pressure. Find the volume it will occupy at 10⁰ C and 335mmHg. (2mks)

8. Study the flow chart below and answer the questions that follow.

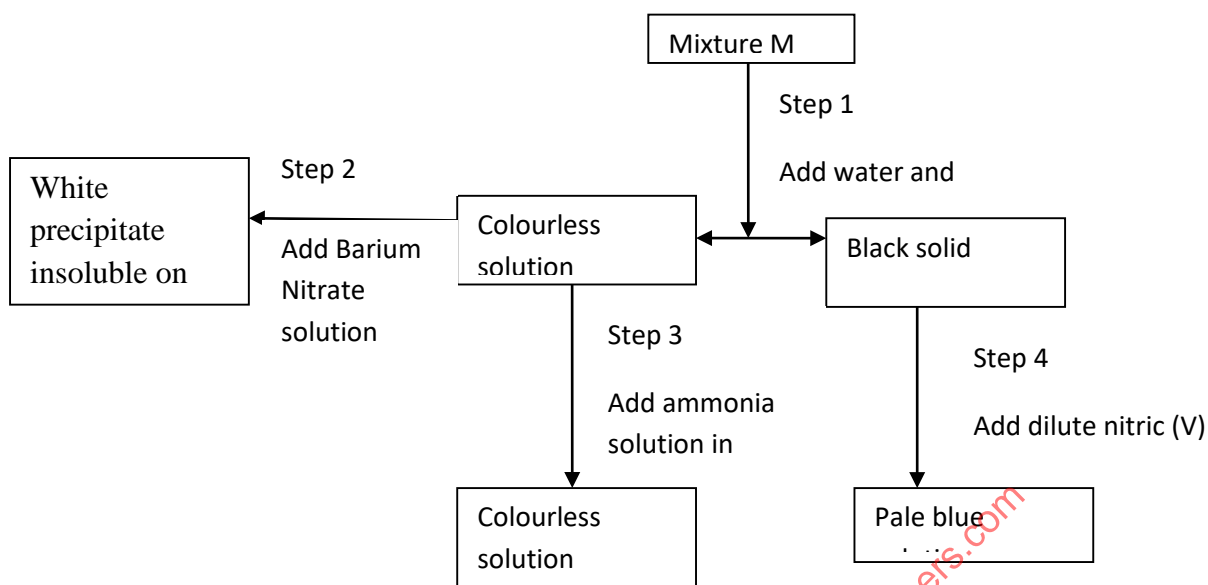

- a) Name
 - (i) Cations present in mixture M. (1mk)
 - (ii) Anion present in the colourless solution. (1mk)
- b) Write an equation to show how the white precipitate in step 3 dissolves. (1mk)
- c) Name the process outlined in step 4 above. (1mk)
9. The solubility of potassium nitrate is 85g/100g of water at 50^o C and 32g/100g of water at 25^o C.
 - (a) Define the term solubility. (1mk)
 - (b) Calculate the mass of the crystals formed if a saturated solution of potassium nitrate in 50g of water at 50^o C is cooled to 25^o C. (2mks)
10. Magnesium Chloride dissolves in water to form a neutral solution while iron (III) chloride forms an acidic solution. Explain. (2mks)
11. The diagram below is a set up to prepare a certain gas X. Study it and use it to answer the questions that follow

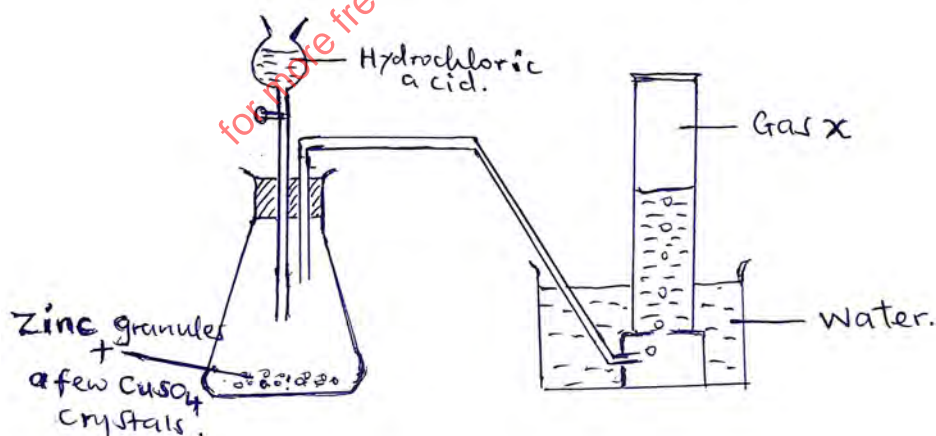

- (a) Identify gas X. (1mk)
- (b) Why is the gas collected over water? (1mk)
- (c) Why are Copper (II) Sulphate crystals added to the flask where the reaction takes place?
12. (a) Give the systematic names of the following organic compounds. (2mks)
 - (i) $\text{CH}_3\text{CH}_2\text{CH}_2\text{CH}_2\text{OH}$
 - (ii) $\text{CH}_3\text{CH}_2\text{COOCH}_2\text{CH}_3$

CHEMISTRY PAPER 1,2 & 3

(b) Explain why an organic compound with the formula C_4H_8 burns with a more sooty flame than C_4H_{10} .
(2mks)

13. When solid Zinc Carbonate was added to a solution of Hydrogen Chloride in methylbenzene there was no observable change. On addition of some water to the mixture there was effervescence. Explain the observation.
(2mks)
14. In titration experiment, 25.0 cm^3 of sodium hydroxide containing 8.0 g per litre was required for complete neutralization of 0.245 g of a dibasic acid. Calculate the relative molecular mass of the acid.
(3mks)
15. (a) 100 g of a radioactive isotope was reduced to 12.5 g after 81 days . Calculate the half life of the radioisotope.
(2mks)
1. $^{212}_{80}\text{Y}$ decays by beta emission. What is the mass number and the atomic number of the product after decay?
(1 mk)
16. (a) Distinguish between ionization energy and electron affinity.
(2mks)
17. The diagram below represents a paper chromatography for three brands of juice suspected to contain unwanted food additives.

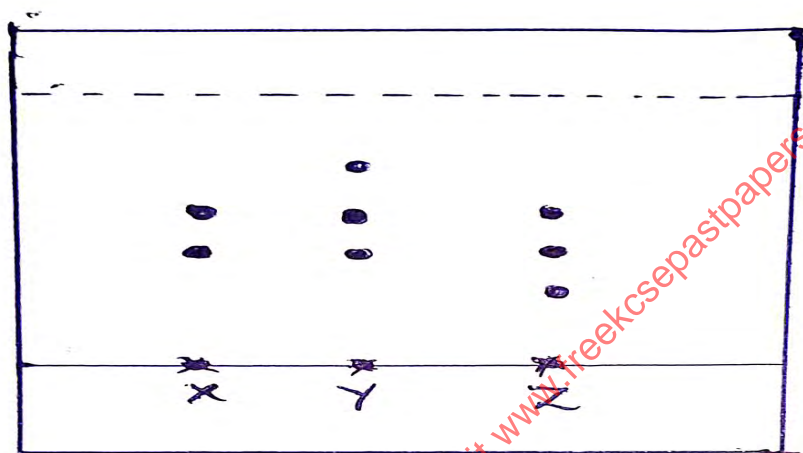

From the results, it was found that unwanted additives are present in Y and Z only.

On the chromatogram;

- a) Circle the spots which show unwanted food additives. (1mk)
- b) Name the solvent commonly used in paper chromatography. (1mk)
- c) State two applications of chromatography. (2mks)
18. (a) Show bonding in Aluminium Oxide. (1mk)

(b) Identify the type of bonds represented by p and q in the substances below.

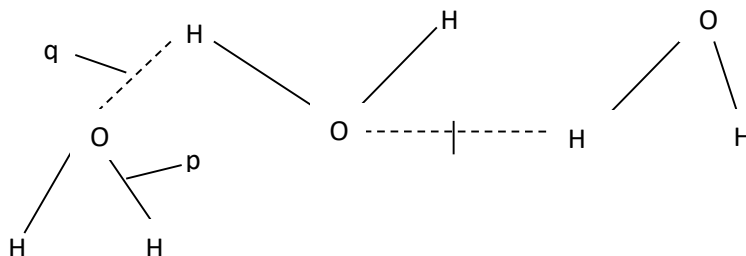

q
p-
q-

($\frac{1}{2}$ mk)
($\frac{1}{2}$ mk)

19. The following diagram represents a charcoal burner. Study it and answer the questions that follow:

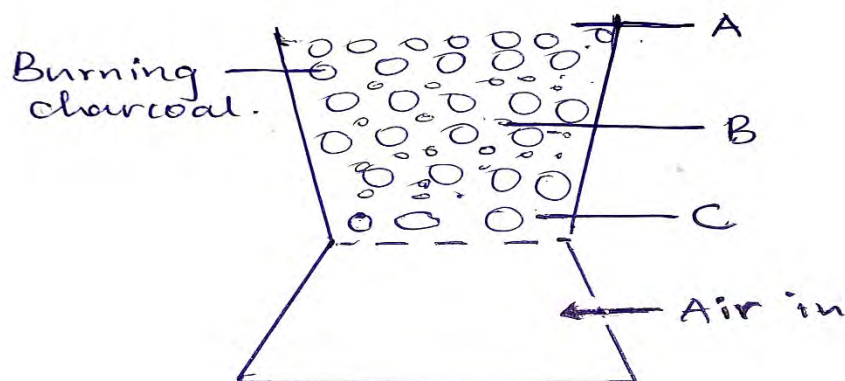

Write the equations for the reactions at A,B and C regions.

(3mks)

20. Use the scheme below to answer the question that follow.

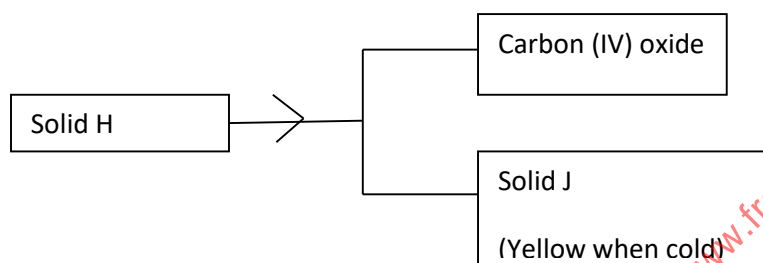

a) Identify process N.

(1mk)

b) Identify the solids

H-

(½ mk)

J-

(½ mk)

21. Ammonia gas is prepared by Harber process according to the equation below:

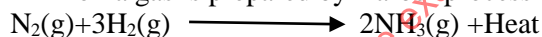

State and explain the effect on equilibrium when the following conditions are applied.

(a) Pressure increased.

(1mk)

(b) Temperature increased.

(1mk)

(c) State Le Chatelier's principle.

(1mk)

22. You are given the following half equations.

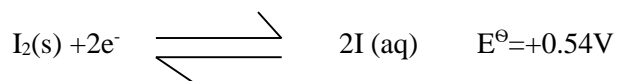

(a) Write an overall equation for the cell reaction.

(1mk)

(b) Calculate the E^\ominus value of the cell.

(1mk)

(c) Name the oxidizing agent.

(1mk)

23. When a current of 0.8Amperes was passed for 44 minutes and 20 seconds through fused iodide of metal Z, 0.7167g of Z was deposited. Determine the charge of the ion of metal Z.

(1 Faraday=96500C,RAM of Z=65)

(2mks)

24. The set up below shows how small pieces of copper are heated in nitrogen (I) Oxide.

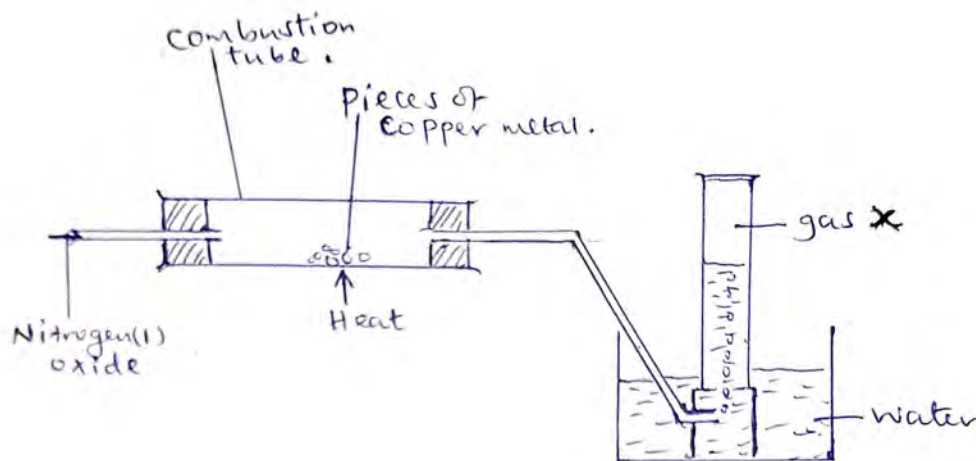

- (a) Write an equation for the reaction which occurs in the glass jar. (1mk)
 (b) Give one use of the Nitrogen (I) Oxide. (1mk)
25. State what would be observed if concentrated Sulphuric (VI) Acid is added to:
 (a) Sugar crystals. (1mk)
 (b) Hydrated Copper (II) Sulphate crystals. (1mk)
 (c) What type of reaction has taken place above. (1mk)
26. Explain why commercial indicators are preferred to flower extracts as acid base indicators. (2mks)
27. (a) Magnesium reacts with hydrochloric acid according to the following equation.

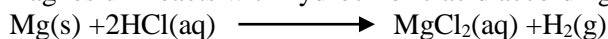

- Identify the reducing agent. Give a reason for your answer. (2mks)
- (b) Iron sheets are dipped in molten Zinc to prevent rusting. Name this process. (1mk)
28. Explain why a balloon filled with helium gas deflates faster than a balloon of the same size filled with argon gas. (2mks)
29. Complete the table below. (2mks)

Solution	PH	Nature of Solution
H	1.0	
I		Neutral
J		Weak acid
K	13.0	

30. A farmer intended to plant cabbages in his farm. He first tested the PH of the soil and found it to be 3.0. If cabbages do well in alkaline soils, explain the advice that would be given to the farmer in order to realize a high yield. (2mks)
31. Name an appropriate apparatus:
 (a) That is used to prepare standard solutions in the laboratory. (1mk)
 (b) That is used in heating solid substances strongly. (1mk)
 (c) That can be used to separate two immiscible liquids. (1mk)
32. Some plants have seeds that contain vegetable oil.
 (a) State the reagent and apparatus used to extract the oil from the seeds. (1mk)
 (b) Explain how it could be confirmed that the liquid obtained from the seeds is oil? (1mk)
 (c) State an application of the method of extracting oil above. (1mk)

1. The diagram below shows a set up used by a student in an attempt to prepare collect oxygen gas

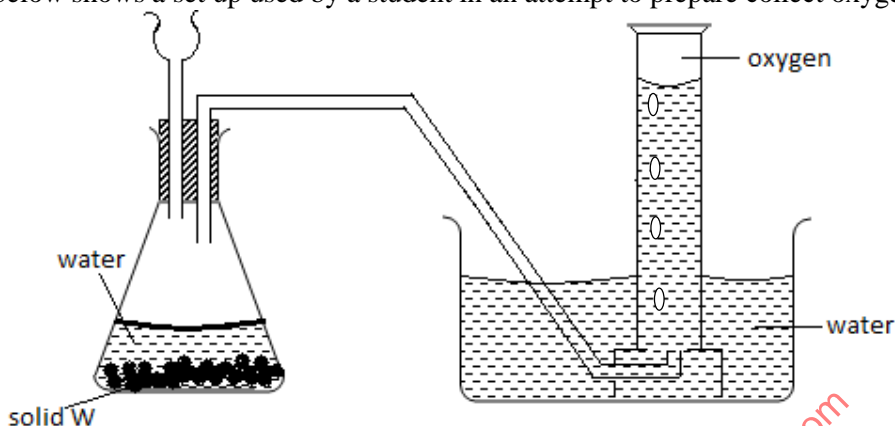

- a) i) Identify and correct the mistakes in the set up to enable the preparation and collection of the gas. (2mks)
 ii) Identify solid w. (1mk)
- b) A piece of phosphorous was burnt in excess air. And the product dissolved in hot water to make a solution.
 i) Write an equation for the burning of phosphorous in excess air. (1mk)
 ii) The solution obtained in (b) above was found to have a pH of 2.0. Give reasons for this observation. (1mks)
- c) Explain why cooking pots made of aluminium do not corrode easily when exposed to air. (1mk)
- d) The reaction between sulphur (IV) Oxide and oxygen to form Sulphur (VI) Oxide is an exothermic reaction, which can be represented by the equation below;

$$2\text{SO}_{2(g)} + \text{O}_{2(g)} \rightleftharpoons 2\text{SO}_{3(g)} \quad H = -ve \quad \Delta$$

A factory manufacturing sulphuric (VI) acid by contact process produces 350kg of sulphur(VI)oxide per day (conditions for the reaction; catalyst, 2 atmospheres pressure and temperatures between 400 – 500 °C.)

- i) What is meant by an exothermic reaction? (1mk)
 ii) How would the yield per day of sulphur trioxide be affected if temperatures lower than 400°C are used? Explain. (1mk)
 iii) All the sulphur (VI) Oxide produced was absorbed in concentrated sulphuric acid to form oleum.

$$\text{SO}_{3(g)} + \text{H}_2\text{SO}_{4(l)} \rightarrow \text{H}_2\text{S}_2\text{O}_7(l)$$

Calculate the mass of oleum that was produced per day. (S = 32.0, O= 16: H = 1.0) (3mks)

2. Study the table below and answer the questions that follow:

Compounds	Melting point °C	Boiling points °C
C ₂ H ₄ O ₂	16.6	118
C ₃ H ₆	-185.0	-47.7
C ₃ H ₈ O	-127	97.2
C ₅ H ₁₂	-130	36.3
C ₆ H ₁₄	-95.3	68.7

CHEMISTRY PAPER 1,2 & 3

- (a) (i) Which of the compounds is a solid at 10°C. Explain (1mk)
 (ii) Choose two compounds which are members of the same homologous series and explain the difference in their melting points (3mks)
 (iii) The compound C₃H₈O is an alcohol. How does its solubility in water differ from the solubility of C₅H₁₂ in water? Explain (2mks)
- (b) Complete combustion of one mole of a hydrocarbon produces four moles of carbon (IV) oxide and four moles of water.
 (i) Write the formula of the hydrocarbon (1mk)
 (ii) Write the equation for the complete combustion (1mk)
- (c) (i) In a reaction, an alcohol "J" was converted to hex -1-ene. Give the structural formula of alcohol "J" (1mk)
 (ii) Name the reagent and conditions necessary for the reaction in C (ii) above (1mk)
- (d) Compound K reacts with sodium hydroxide as shown below

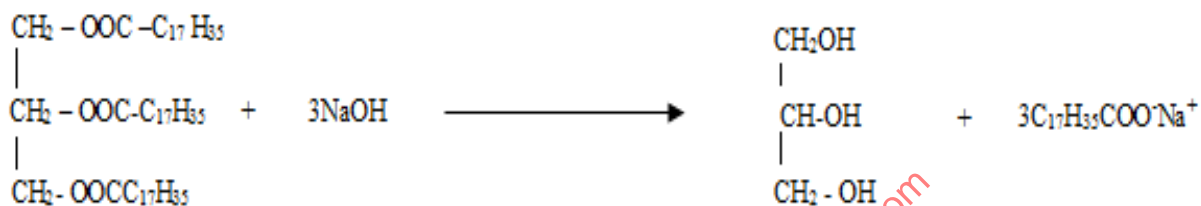

- (i) What type of reaction is represented by the equation above (1mk)
 (ii) To what class of compound does "K" belong? (1mk)
- (e) The following equations represent two different types of reactions

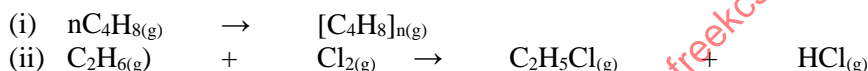

State the type of reaction represented by (i) and (ii) (1mk)

3. (a) Give the name of one reagent which when reacted with concentrated hydrochloric acid produces chlorine gas (1mk)
 (b) A student set out to prepare iron (III) chloride using apparatus shown in the diagram below

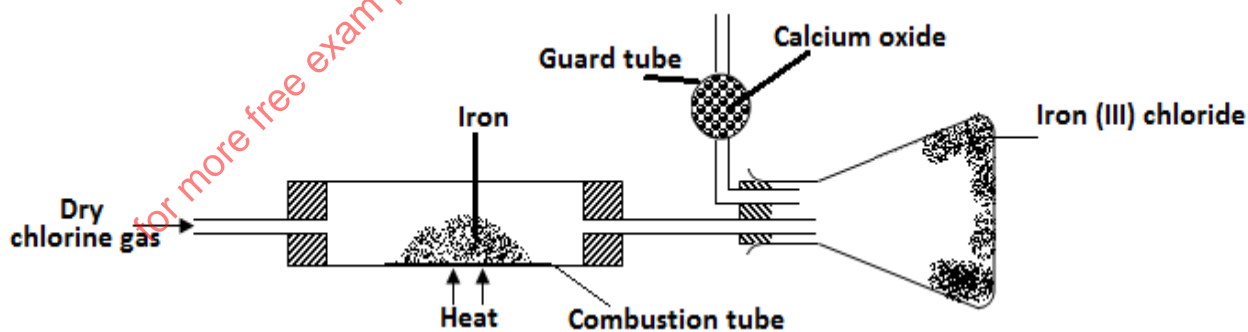

- (i) Explain why it is necessary to pass chlorine gas through the apparatus before heating begins? (1mk)
 (ii) What property of iron (III) chloride makes it possible to be collected as shown in the diagram (1mk)
 (iii) The total mass of iron (III) chloride formed was found to be 0.5g. Calculate the volume of chlorine gas that reacted with iron. (Fe = 56, Cl = 35.5 and molar gas volume at r.t.p is 24,000 cm³) (3mks)
- (c) When hydrogen sulphide gas passed through a solution of iron (III) chloride the following observation was made;
 The colour of the solution changed from reddish brown to green and yellow solid was deposited. Explain these observations (2mks)
- (d) State and explain the observations that would be made if a moist blue-litmus paper was placed in a gas jar full of chlorine gas (2mks)

CHEMISTRY PAPER 1,2 & 3

(e) Study the information to answer the questions that follow. The letters do not represent the actual symbols of the elements.

Elements	Atomic number	Melting point ($^{\circ}\text{C}$)
L	11	97.8
M	13	660
N	14	1410
C	17	-101
R	19	63.7

- a) i) Write the electron arrangement for the ions formed by elements “M” and “C” (1mk)
 ii) State the type of the bond that will be formed when M and C react. (1mk)
 iii) In which group and period of the periodic table does element “R” belongs? (1mk)
 iv) Element R loses its outermost electrons more readily than “L”. Explain (1mk)
 v) Using dots and crosses to represent electrons, show bonding in the compound formed between N and C. (2mks)

4. Study the energy level diagram below and answer the questions that follow.

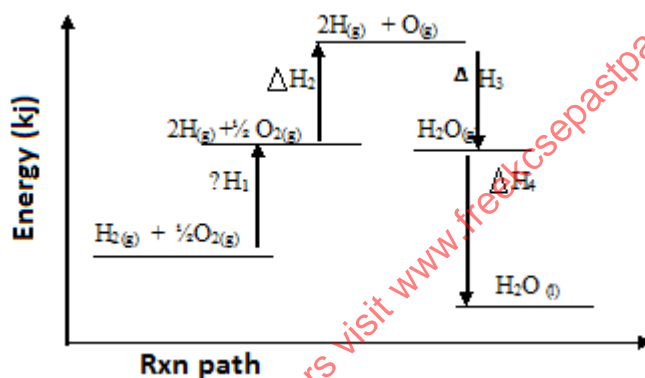

- (a) (i) Which H values have a positive sign (1mk)
 (ii) Which H values have a negative sign (1mk)
 (iii) What chemical changes is being represented by (2mks)
 H₁
 H₄

b. The hydration energy of Al^{3+} and Cl^- are -4690 and -364kJmol^{-1} respectively. The heat of solution of aluminium chloride is -332kJ mol^{-1} .

- (i) Calculate the lattice energy of aluminium chloride (2mks)
 (ii) Draw an energy level diagram for dissolving of aluminium chloride (2mks)

(c) When one mole of butanol is burnt, 2676kJ are liberated

- (i) Write a chemical reaction for combustion of butanol. (1mk)
 (ii) Considering the following heats of combustion

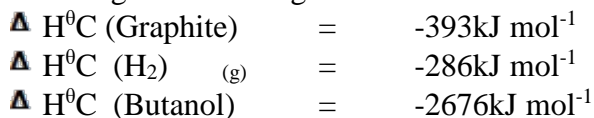

Draw an energy cycle for the above energy changes (2mks)

- (iii) Calculate the heat of formation of butanol (2mks)

5. (a) The equations below shows the standard reduction potential for four half cell. Study it and answer the questions that follow. Letters are not actual symbols of the element.

E° Volts

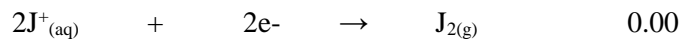
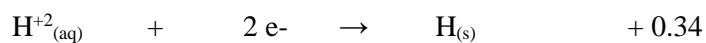
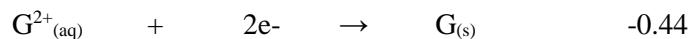

- i. Write the equation for the reaction which takes place when solid “G” is added to a solution containing H^{2+} (ions) (1mk)
- ii. Calculate the E° value for the reaction in (ii) above (1mk)

(b)The diagram below shows the apparatus used to electrolyze acidified water to obtain hydrogen and oxygen gases. Study it and answer the questions that follows?

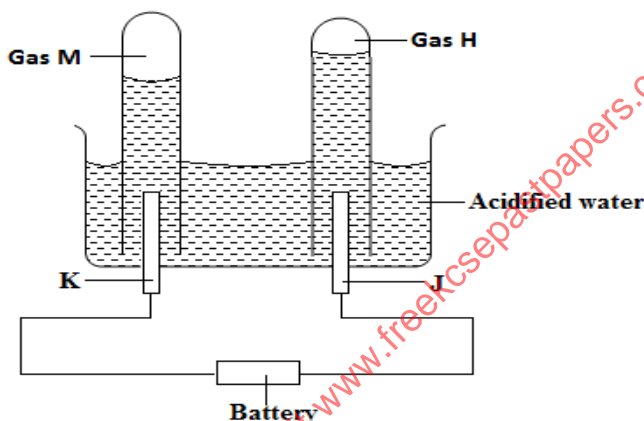

- i. Identify the electrodes marked K and J (1mk)
 - ii. Write the equation that led to the production of gas (1mk)
 - iii. Explain why hydrochloric acid is not used to acidify the water (1mk)
- (c) During electrolysis of aqueous copper (II) sulphate 144750 coulombs of electricity were used. Calculate the mass of copper metal that was obtained (Cu= 64, 1 Faraday = 96500 Columbus) (2mks)
6. The flow chart illustrates the extraction of zinc and preparation of Zinc (II) sulphate crystals. Study it and answer the questions that follow

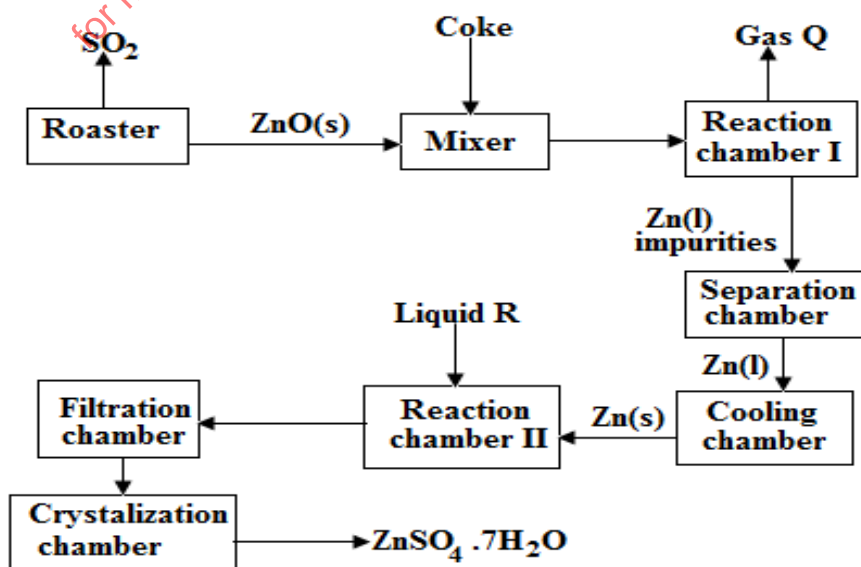

CHEMISTRY PAPER 1,2 & 3

(a) Name

I. Gas Q (1mk)

II. Liquid R (1mk)

(ii) Write an equation for the reaction that takes place in

Chamber I (1mk)

The Roster (1mk)

Chamber II (1mk)

(iii) Given that the zinc sulphide ore contain 45% of Zinc sulphide by mass, calculate

I. The mass in grains of Zinc sulphide that would be obtained from 250 kg of the ore. (1mk)

II. The volume of sulphur (IV) oxide (SO_2) that would be obtained from the above mass of zinc sulphide at room temperature and pressure ($S = 32.0$, molar gas volume = 24 dm^3). (2mks)

III. The mass of zinc metal that would be obtained in I above ($\text{Zn} = 65.4$) (1mk)

(b) In such an experiment sulphur (IV) Oxide may keep escaping to the atmosphere. Explain how this could affect the environment. (1mk)

(c) Suggest one other manufacturing plant that could be set up near Zinc extraction plant. (1mk)

7. (a) State the difference between chemical and nuclear reactions (1mks)

(b) Below is a radioactive decay series starting from

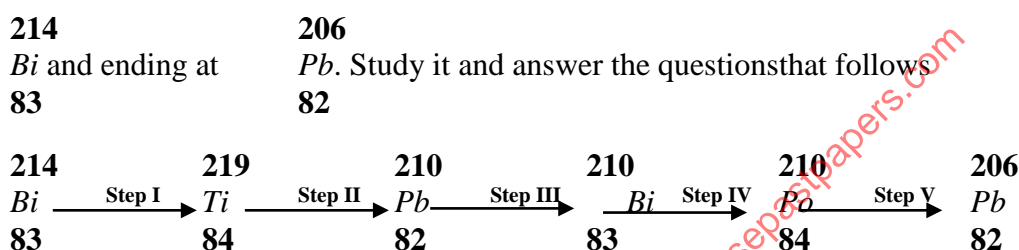

(i) Identify the particle emitted in step I and III. (2mks)

(ii) Write the nuclear equation for the reaction which takes place in step V (1mk)

(c) The table below gives the percentage of radioactive isotope of Bismuth that remains after decaying at different times.

Time (mm)	0	6	12	22	38	62	100
Percentage of Bismuth	100	81	65	46	29	12	3

(i) On the grid provided below, plot a graph of the percentage of bismuth remaining (vertical axis) against time (3mks)

(ii) Use the graph, determine the

I. Half life of the Bismuth (1mk)

II. Original mass of bismuth isotope given that the mass remained after 70 minutes was 0.16g

(1mks)

(c) Give one use of radioactive isotope in medicine (1mk)

CHEMISTRY PAPER 1,2 & 3
LANJET CLUSTER JOINT MOCK EXAM
DECEMBER 2020
CHEMISTRY PP3

CONFIDENTIAL

In addition to the fittings and Chemical found in the lab each candidate will require the following.

1. Solid A. 17cm long magnesium ribbon
2. 80cm³ of solution B
3. 120cm³ of solution C
4. 1g of solid E in a container
5. 0.5g of solid F in a container
6. About 500cm³ of distilled water.
7. One 25ml pipette
8. One 50ml burette
9. One 100ml plastic beaker
10. Thermometer (-10⁰c to 110⁰c)
11. Stop watch
12. Two 250ml conical flask
13. One 250ml volumetric flasks
14. 6 dry test tubes in rack
15. Two boiling tubes
16. One metallic spatualla
17. One piece each of red and blue litimus paper
18. Piece of universal indicator paper
19. Label
20. About one cm² Aluminum foil.

Access to

1. Phenolphthalein indicator supplied with a dropper.
2. Bunsen burner
3. Universal indicator and PH chart
4. 2M sodium hydroxide supplied with a dropper
5. Barium Nitrate supplied with a dropper
6. Acidified potassium magnate (vii) supplied with a dropper
7. Freshly prepared bromine water supplied with a dropper
8. 0.5M sodium sulphate supplied with a dropper
9. 0.5M sodium Chloride supplied with a dropper.
10. 0.5M lead (ii) Nitrate

Preparations

1. Solid A is 0.4g of Mg exactly 17cm long. Mg ribbon
2. Hydrochloric acid solution B is prepared by adding 172cm³ of concentrated hydrochloric acid of specific gravity 1.18gcm⁻³ to 500cm³ of distilled water in one litter volumetric flask then adding distilled water to the mark. Label this as solution B.
3. Solution C made of adding 12g of NaOH pellet in 200cc of distilled water, stir then top it up in 1000ml volumetric flask.
4. Acidify potassium mangate (vii) prepared by dissolving 3.2g of potassium manganate vii in 200cm³ of 2M sulphuric acid in 1L volumetric flask then adding water to the mark.
5. Barium Nitrate prepared by dissolving 26g of barium Nitrate in 800cm³ of distilled water then topping up to 1L.
6. Solid E is about 1g of barium Nitrate.
7. Solid F is 0.5g Malleic acid.

CHEMISTRY PAPER 1,2 & 3

ii) Calculate the number of moles of:

- a) 0.3M NaOH (1mk)
- b) Hydrochloric acid in 25cm³ of solution D. (1mk)
- c) Hydrochloric acid in 250cm³ of solution D. (1mk)
- d) Hydrochloric acid in 50cm³ of solution B. (1mk)
- e) Hydrochloric acid that reacted with magnesium. (1mk)
- f) Magnesium that reacted. (1mk)

c) Using your answer in iv above, determine molar heat of reaction between magnesium and hydrochloric acid. Assume the heat capacity of solution is 4.2Jg⁻¹k⁻¹ and density of solution 1g/cm³. (2mks)

2. You are provided with solid E. Carry out the experiments below. Write your observation and inferences in the space provided.

a) Place all solid E in a boiling tube. Add about 20cm³ distilled water and shake until all the solid dissolves label this solution E. use solution E for experiments (i) and (ii)

i) To 2cm³ of solution E in a test tube in each of experiments I,II,III and IV add:

I Two drops of aqueous sodium sulphate;

Observations

(1mk)

Inferences

(1mk)

II Five drops of aqueous sodium chloride;

Observations

(1mk)

Inferences

(1mk)

III Two drops of barium Nitrate;

Observations

(1mk)

Inferences

(1mk)

IV Two drops of lead (ii) Nitrate

Observations

(1mk)

Inferences

(1mk)

ii) To 2cm³ of solution E in a test tube add 5 drops of aques sodium hydroxide. Add a piece of Aluminium foil provided to the mixture and shake. Warm the mixture and test any gas produced with the and read litmas papers.

Observations

(2mk)

Inferences

(1mk)

3. You are provided with solid F. Carry out the following tests and record the observations and inference in the space provided.

CHEMISTRY PAPER 1,2 & 3

a) Place about one third of the solid F on a clean metallic spatula and burn it in a Bunsen burner flame.

Observations

Inferences

(1mk)

(1mk)

b) Place the remaining amount of solid F in a boiling tube. Add about 10cm³ of distilled water and shake use the mixture for tests (i) to (ii)

Observations

Inferences

(½mk)

(½mk)

i) Using about 2cm³ of the mixture in a test tube determine the PH Using universal indicator paper and chart.

PH

Inferences

(1mk)

(1mk)

ii) To about 2cm³ of the mixture in a test tube add three drops of acidified potassium manganese vii.

Observations

Inferences

(1mk)

(1mk)

iii) To about 2cm³ of the mixture in a test tube add two or three drops of bromine water.

Observations

Inferences

(1mk)

(1mk)

for more free exam papers visit www.freekcepapers.com

CHEMISTRY

1. a) Draw the structural formula of the following:
 - i) Ethyne (1 mark)
 - ii) Ethane (1 mark)
- b) What is a saturated hydrocarbon? (1 mark)
2. The grid below represents part of the periodic table. Study it and answer the questions that follow:

					D				
					E	F	I		
A						G			
B	C								

- i) Compare the reactivity of elements A and B (1 mark)
- ii) State two uses of element I. (1 mark)
- iii) Write electron configuration of element F (1 mark)
3. i) Define the term solubility. (1 mark)
- ii) Use the information below to calculate the solubility of sodium nitrate.

Mass of evaporating dish = 15.10g
 Mass of evaporating dish and salt = 20.10g
 Mass of evaporating dish and solution = 40.10g (2marks)
4. Potassium consists of three isotopes with mass numbers Y, 40 and 41 having relative abundances 93.1%, 0.01% and 6.89% respectively. Determine the value of Y given the atomic number of potassium is 19 and its relative atomic mass is 39.1379 (3 marks)
5. Describe how Hydrogen gas can be tested and confirmed in the laboratory (2 marks)
6. 200 cm³ of oxygen gas took 90 seconds to diffuse through a porous plug. Determine the time taken by 300 cm³ of Sulphur (IV) oxide to diffuse through the same plug under the same conditions. (O= 16, S = 32). (3marks)
7. When 8.8g of hydrocarbon Z was burnt in excess air, 14.4g of water and 11.95 dm³ of carbon (IV) oxide were obtained at s.t.p. Determine the empirical formula of Z. (MGV=22.4dm³) (3marks)
8. (a) The diagram below is a set-up to prepare ethyne gas

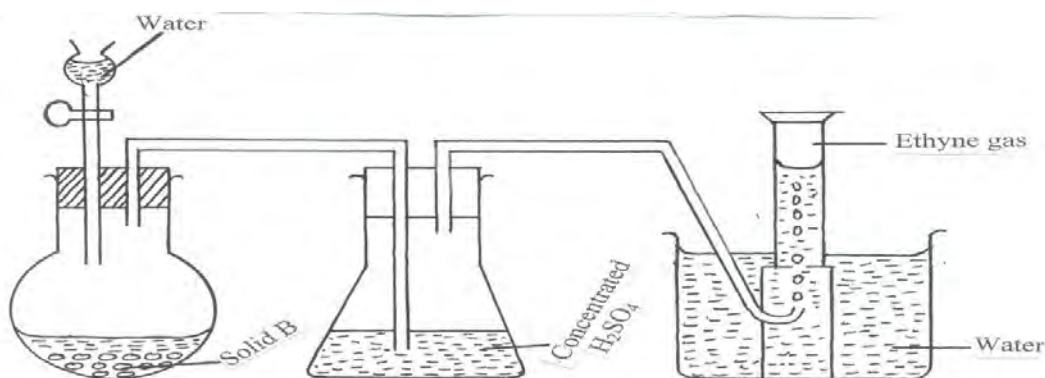

- (i) Name solid B (1 mark)
- (ii) Write an equation for the reaction taking place between solid B and water. (1 mark)
- (iii) State the property that makes the gas to be collected by the method shown in the diagram

(1 mark)
(1 mark)

(iv) State one use commercial use of ethyne.

9. Study the set up below and answer the questions that follow.

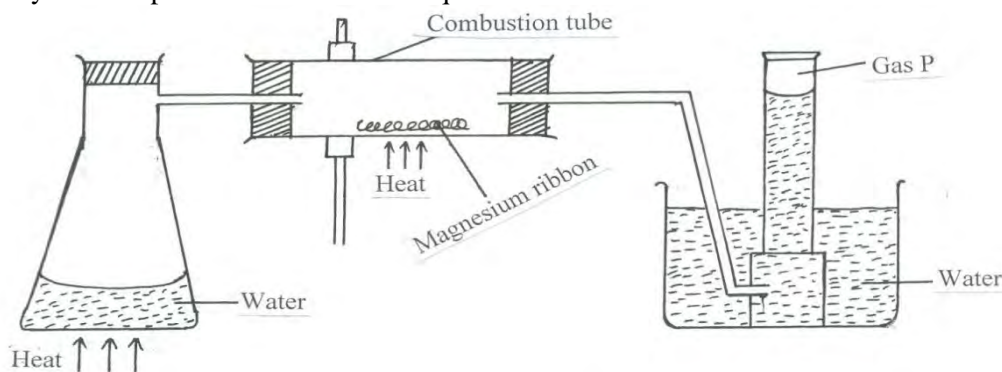

- (a) Name gas P ... (1 mark)
- (b) Write a balanced equation for the reaction which takes place in the combustion tube. (1 mark)
- (c) State and explain what would happen if magnesium would be replaced with copper. (1 mark)

10. The products formed by action of heat on nitrates of element X, Y and Z are shown below.

Nitrate of	Products formed
X	X oxide + Nitrogen (IV) Oxide + Oxygen
Y	Y + Nitrogen (IV) Oxide + Oxygen
Z	Z nitrite + oxygen

- a) Arrange the metals in order of increasing reactivity. (1 mark)
 - b) Which element forms a soluble carbonate? (1 mark)
 - c) Give an element that can be Y. (1 mark)
11. Describe how you would fully separate solid lead (II) carbonate from a mixture of lead (II) carbonate, Iron filings and sodium carbonate. (3 marks)
12. The diagram below represents a set up used for the large scale manufacture of hydrochloric acid.

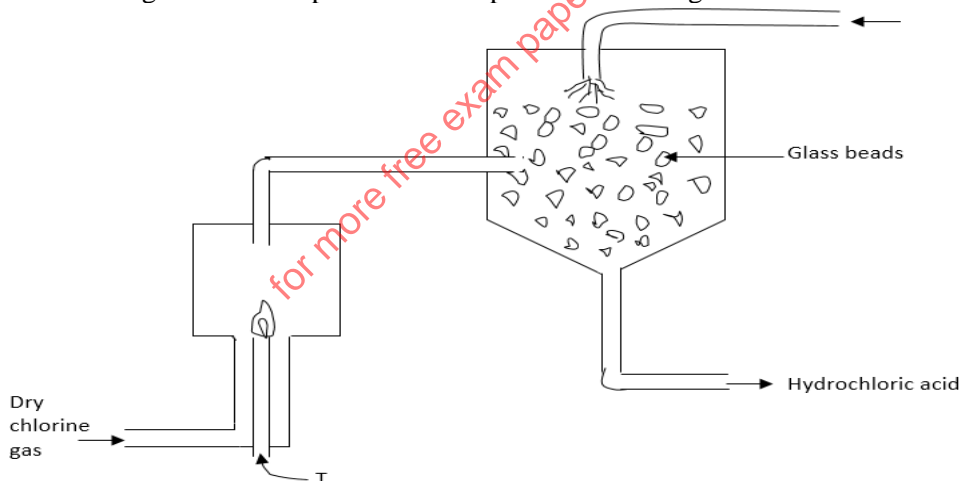

- a) Name substance T..... (1 mark)
- b) What is the purpose of the glass beads? (1 mark)
- (c) Give one use of hydrochloric acid. (1 mark)

13. Give equations to show the reactions that take place when;

- i) Mg reacts with dilute hydrochloric acid (1 mark)
 - ii) Iron react with steam (1 mark)
- (b) Give one industrial use of the gas produced in the reactions in a(i) and a(ii) above. (1 mark)

14. Study the set up below and answer the questions that follow.

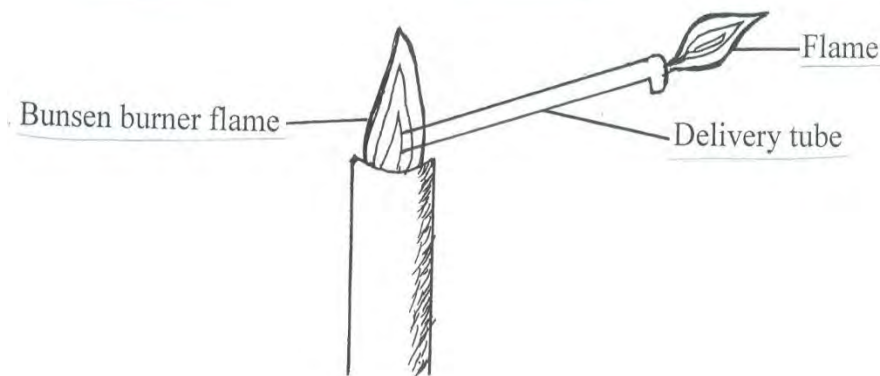

- (a) What does the experiment demonstrate? (1 mark)
- (b) When is this type of Bunsen burner flame produced? (1 mark)
- (c) Give two characteristics of the type of flame used in the above set-up. (1 mark)

15. The set-up below was used to study some properties of air.

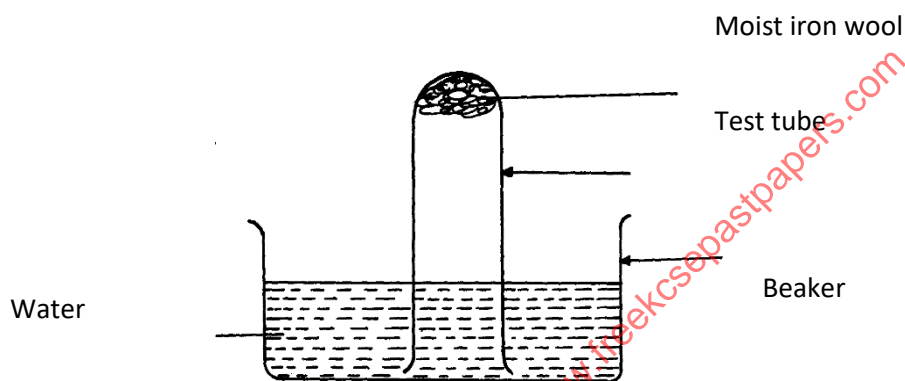

State and explain **two** observations that would be made at the end of the experiment (2 marks)

ii) State any two methods of preventing rusting (1 mark)

16. Study the table below and answer the questions that follow. The letters do not represent the actual symbols of the element.

Formula of ion	Electronic configuration
E ²⁺	2
D ⁻	2.8
C ⁻	2.8.8
B ³⁺	2.8
A ²⁺	2.8

Select elements found in: -

- i) The same group (1 mark)
- ii) Period three..... (1 mark)
- iii) What is the family name given to the group number to which element E belongs (1 mark)

17. The set-up below is used to prepare dry sulphur (IV) Oxide in the laboratory. Answer questions that follow:

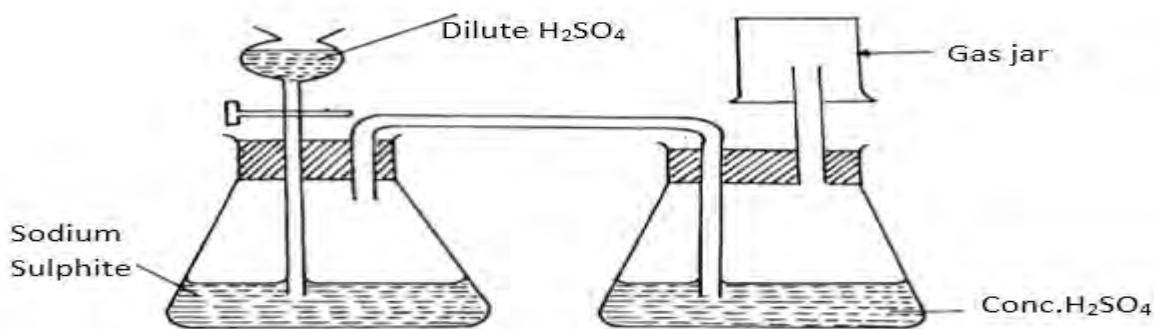

- (a) Identify the mistake in the set-up
- (b) Write an equation for the reaction in the set-up
- (c) State how the polluting effects of the gas on the environment can be controlled

18. The set – up below was used to react dry chlorine gas with iron powder. The product Z was collected in flask B.

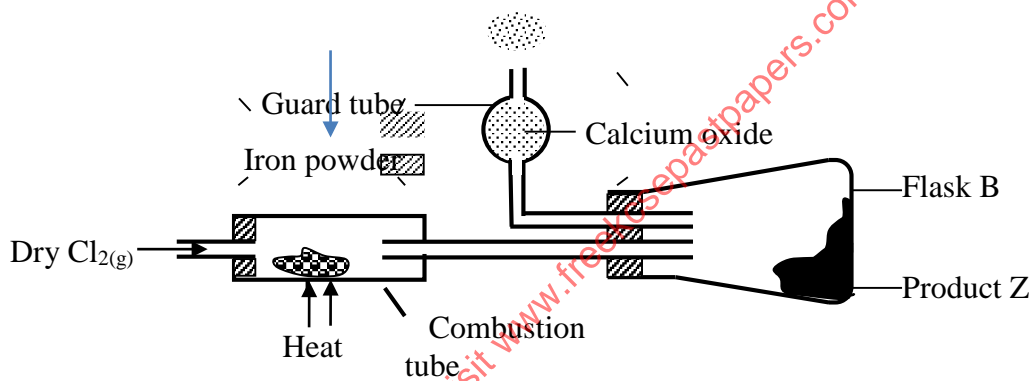

- a) Identify product Z. (1 Mark)
- b) i) What property of product Z makes it possible to be collected as shown in the diagram (1 Mark)
- ii) Explain why calcium oxide would be preferred to calcium (II) chloride in the guard tube (1 Mark)

19. Concentrated sulphuric (VI) acid was added to white crystals as shown. The colourless gas P formed was passed over heated manganese (IV) oxide and a gas Y which bleached litmus paper was produced. The experiment was repeated using powdered magnesium metal instead of manganese (IV) oxide. This time a gas R which burned in air with a blue flame was formed.

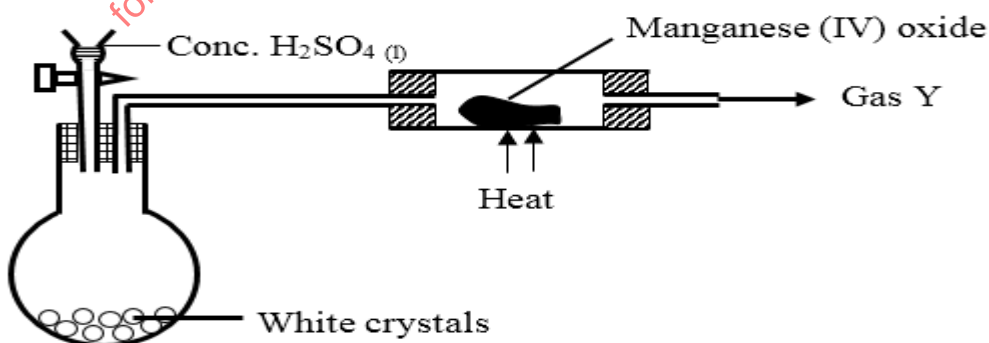

- (a) (i) Name gases
- Y
- (1Mark)
- R
- (1Mark)

(ii) What type of chemical reaction occurred between gas P and manganese (IV) oxide

(1 Mark?)

20. The table below shows the pH values of some solutions.

Solution	A	B	C	D	E
pH	6.5	13	2	10	7

a) Which solution is likely to be

- (i) Sodium Hydroxide (1/2mark)
- (ii) Ammonia solution..... (1/2mark)
- (iii) Distilled water (1/2mark)
- (iv) Wood ash..... (1/2mark)
- (v) The pH of rain water in an industrialized area. Explain (1mark)

21. The following is a chromatogram showing the results obtained after separating two Substances P and T.

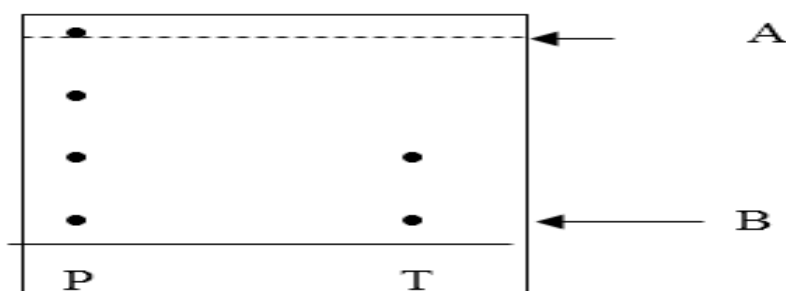

(a) Name :

A (1 mark)

B (1 mark)

(b) Name a possible solvent which can be used in the above process. (1 mark)

22. The diagram below represents an arrangement for preparing and collecting dry hydrogen. Study it and answer the questions that follow.

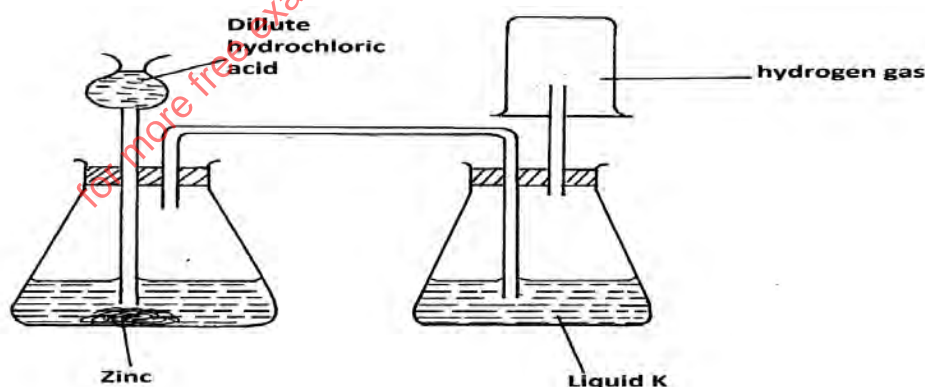

a) Write the equation for the reaction that produces hydrogen gas (1mark)

b) Name the suitable substance that liquid K is likely to be. (1mark)

c) Explain why it is not advisable to use nitric (v) acid as an alternative acid in the (1mark)

23. Study the information in the table and use it to answer the question that follow.

Elements	Na	Mg	Al	Si	P	S	Cl
Atomic number	11	12	13	14	15	16	17
Atomic radii (nm)	0.157	0.136	0.136	0.117	0.110	0.104	0.099

- State the trend in atomic radii from Sodium to chlorine (1mark)
- Explain how the chloride of Aluminium differ from those of other metals in the period (2marks)

24. The diagram below is a set-up used in preparation of ammonia solution. Study it and answer the questions that follow

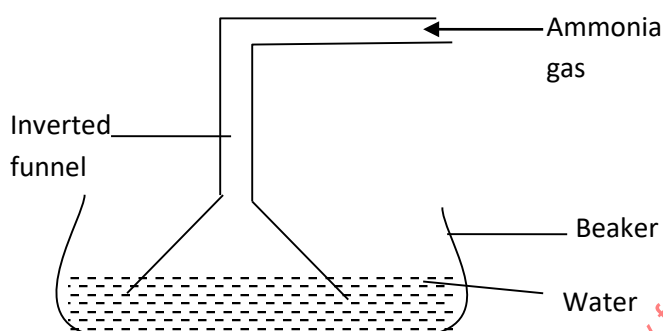

- What is the purpose of the filter funnel in the set-up above? (1mark)
- What would happen if a delivery tube was used in place of the filter funnel? (1mark)
- What observation would be made on red litmus paper placed into the solution in the beaker at the end of the experiment? (1mark)

25. The setup below was used to investigate the reaction between calcium metal and water.

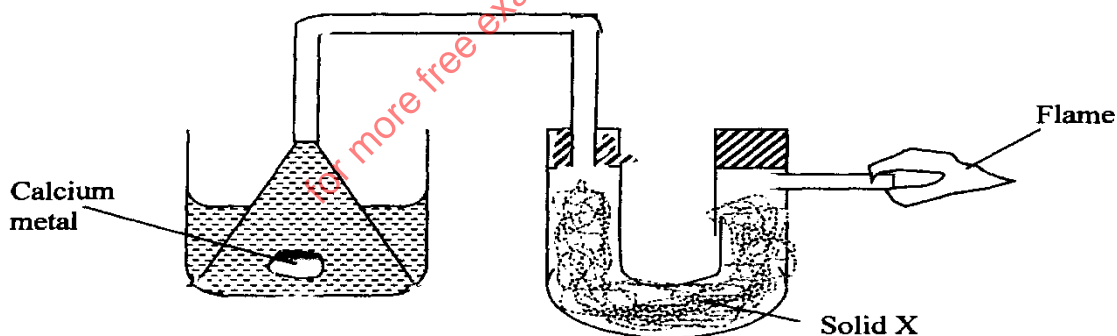

CHEMISTRY PAPER 1,2 & 3

- (a) Identify solid **X** and state its purpose
(b) Write a chemical equation for the reaction that produces the flame. (1 mark)
26. A fertilizer manufacturing industry uses 1400dm^3 of ammonia gas per hour to produce ammonium sulphate. Calculate the amount of ammonium sulphate produced in kg for one day if the factory operates for 18 hours. (N = 14, H = 1, S = 32, O = 16, MGW = 24dm^3) (3marks)
27. In the Haber process, the industrial manufacture of ammonia is given by the following equation:

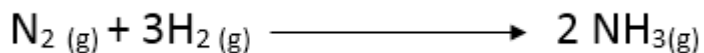

- (a) Name one source of hydrogen gas used in this process. (1 mark)
(b) Name the catalyst used in the above reaction. (1 mark)
(c) State any two uses of ammonia. (1 mark)

for more free exam papers visit www.freekcsepastpapers.com

CHEMISTRY PAPER 2
(THEORY)

1. The figure below represents a section of the periodic table. Study it and answer questions (a) to (c). Note that the letters do not represent the actual symbols of the elements.

A						D	
B			G	J	F	H	E
C						I	

- (a) Consider elements D, H and I
- Give the chemical family of these elements. (1 mark)
 - How do their ionic size compare. Explain. (2 marks)
 - Compare and explain the reactivity of the three elements. (2 marks)
- (b) Write the electronic configuration of:
- Element H (1 mark)
 - The ion of element G. (1 mark)

(c) A molecule of one of the elements is shown below.

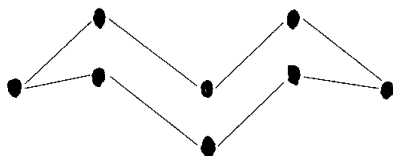

- Identify** this element from the section of the periodic table and give its actual **name**. (2marks)
 - Explain why this element has a higher boiling point compared to that of oxygen. (2 marks)
 - Write an equation to show the reaction between the element named above with oxygen (1 mark)
 - Predict the pH of the oxide of the above element when in water. (1 mark)
2. The diagram below shows an experimental set up for preparing Carbon (II) oxide. Study it and answer the questions that follow.

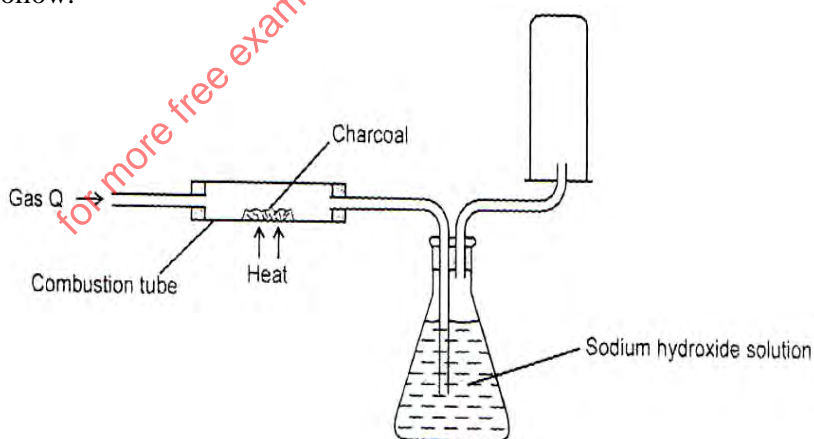

CHEMISTRY PAPER 1,2 & 3

- a) Identify gas Q. (1 mark)
- b) State the reason why Carbon (II) Oxide is collected in the manner illustrated. (1 mark)
- c) Write chemical equations for the reactions taking place in the: (2 marks)
- Combustion tube
 - Conical flask
- d) Describe a simple test that can be used to distinguish between Carbon (II) Oxide and Carbon (IV) Oxide. (2 marks)
- e) State and explain the observation made when concentrated nitric (v) acid is added to charcoal in a test tube. (2 marks)
- f) What is water gas? (1 mark)
3. a) Define the following terms (2 marks)
- Exothermic reaction
 - Activation energy
- b) In an experiment to determine the heat of combustion of methanol, CH_3OH , a student set up apparatus as shown in the diagram below. Study the set up and the data and answer the questions that follow.

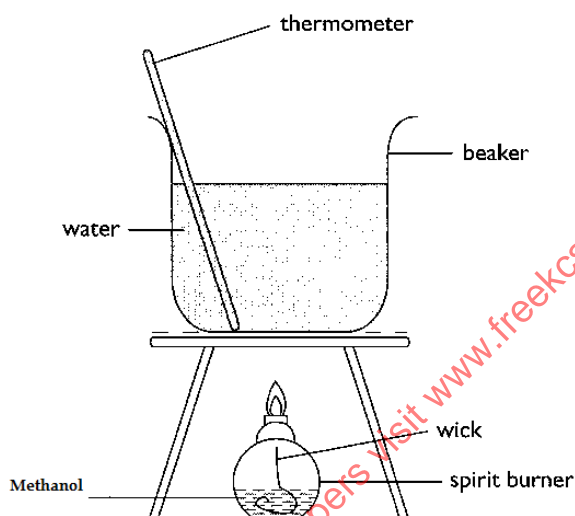

Volume of water = 100cm^3

Final temperature of water = 22.0°C

Initial temperature of water = 36.0°C

Final mass of lamp and methanol = 84.75g

Initial mass of lamp and methanol = 85.10g

Density of water = 1 g/cm^3

(Specific heat capacity of water = $4.2\text{ g}^{-1}\text{K}^{-1}$)

- Write an equation for the combustion of methanol. (1 mark)
 - Calculate: (1 mark)
 - Number of moles of methanol used in this experiment. (1 mark)
- (c) The heat change for this experiment. (2 marks)
- (d) The heat of combustion per mole of methanol. (1 mark)
- d) Explain why the molar heat of combustion for methanol obtained above is different from the theoretical value. (1 mark)
- e) State two factors to consider when choosing a fuel. (2 marks)
- f) Outline two disadvantages of using hydrogen as a source of fuel. (2 marks)

4. Study the flow chart below and answer the questions that follow.

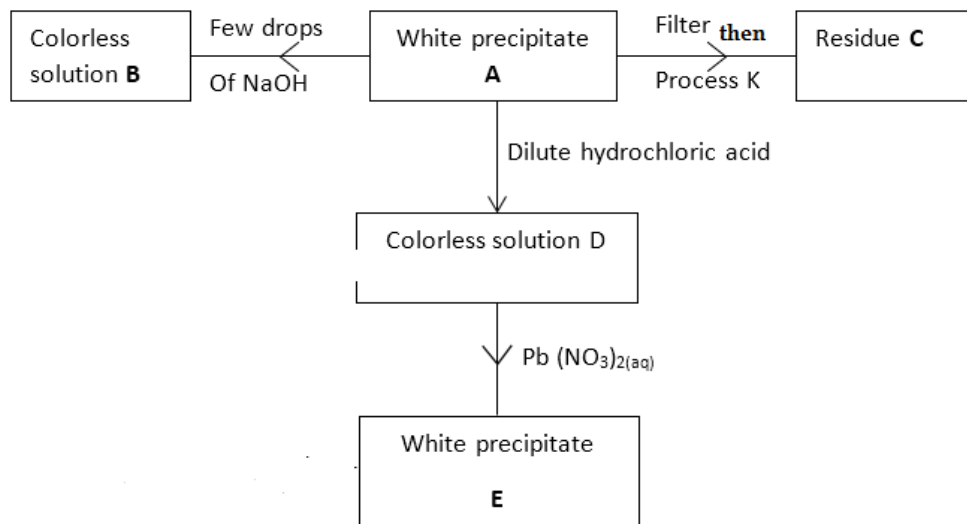

Residue **C** was yellow when hot and white when cold.

- (a) (i) Identify.
- | | |
|------------------------------|----------|
| I White precipitate A | (1 mark) |
| II Solution D | (1 mark) |
| III Residue C | (1 mark) |
- (ii) Write an ionic equation for the reaction of solution **D** with $\text{Pb}(\text{NO}_3)_2(\text{aq})$ (1 mark)
- (iii) Write observations that would be made when ammonia solution is added drop wise till in excess to the colorless solution **D**. (1 mark)
- (iv) Name the property of white precipitate **A** leading to formation of colorless solution **B** (1 mark)
- v) Name process **K** (1 mark)
- (b) Ammonia gas bubbled into water forms a solution which conducts electricity whereas the solution formed when it is bubbled through methylbenzene does not. Explain. (2 marks)
- (c) Boilers used for boiling hard water are normally covered with boiler scales after sometime.
- | | |
|--|----------|
| (i) What is the chemical name for boiler scales? | (1 mark) |
| (ii) How is the boiler scale removed? | (1 mark) |
5. (a) Define the term isomerism (1 mark)
- (b) Give the IUPAC names of the following organic compounds. (2 marks)

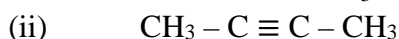
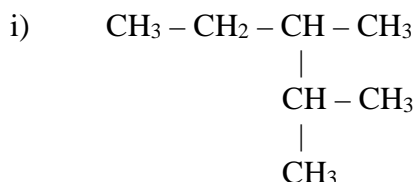

(c) Study the flow chart below and answer the questions that follow:

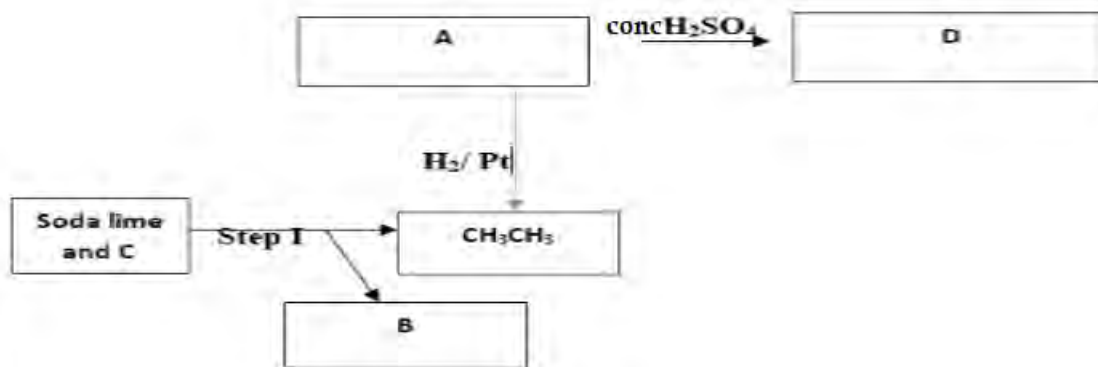

Identify A,B,C & D (4 marks)

(ii) Explain how substance A and CH_3CH_3 could be distinguished by burning. (1 mark)

(iii) Give one reason why soda lime is preferred to pure sodium hydroxide in step I. (1 mark)

(iv) Write down the equation for the reaction between substance A and hydrogen when equal numbers of moles are used. (1 mark)

(v) State one application of the process represented by the equation in (iv) above (1 mark)

d) Name two reagents that can be reacted in the laboratory to produce ethyne gas (2 marks)

6. The figure below was set by a student to investigate the reaction between chlorine gas and hydrogen sulphide gas.

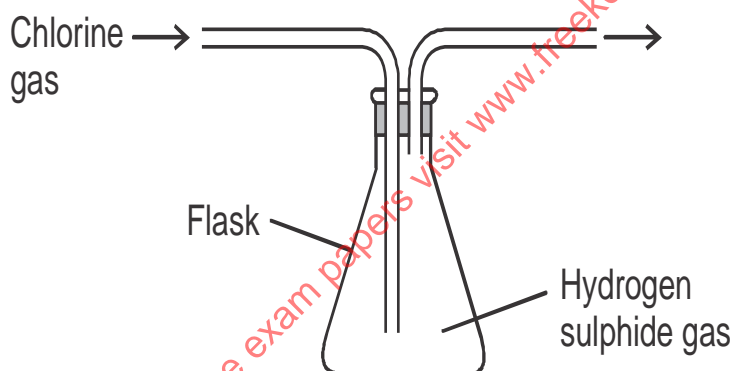

a) i) Write an equation for the reaction that took place in the flask. (1 mark)

ii) What observation was made in the flask? (1 mark)

iii) What precaution should be taken in carrying out the experiment? (1 mark)

b) i) Write a balanced chemical equation for the laboratory preparation of hydrogen sulphide gas. (1 mark)

ii) State and explain the observation made when hydrogen sulphide gas is bubbled through a solution of copper (ii) sulphate solution. (2 marks)

c) Both chlorine and sulphur (IV) oxide are bleaching agents. Distinguish the mode of bleaching of the two gases. (2 marks)

d) The diagram below shows the Frasch process used for extraction of sulphur. Use it to answer the questions that follow.

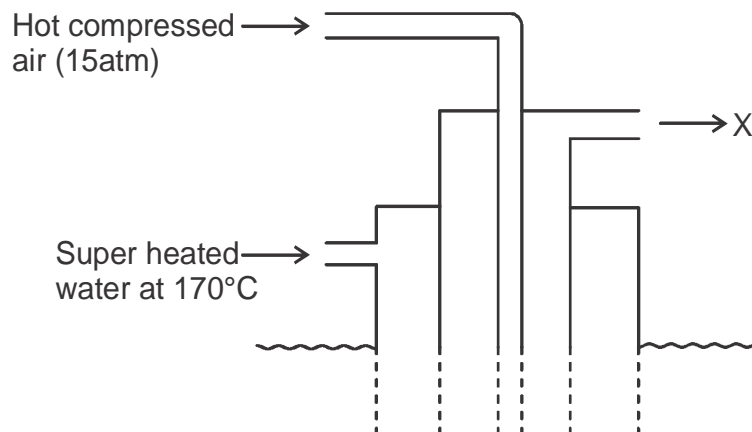

- i) Identify X (1 mark)
- ii) Why is it necessary to use superheated water in this process? (1 mark)
- iii) State two physical properties of sulphur that makes it possible for it to be extracted by this method. (2 marks)
- iv) Name the two crystalline forms of sulphur (1 mark)

7. a) The diagram below shows a set-up used to heat hydrated copper (II) sulphate crystals.

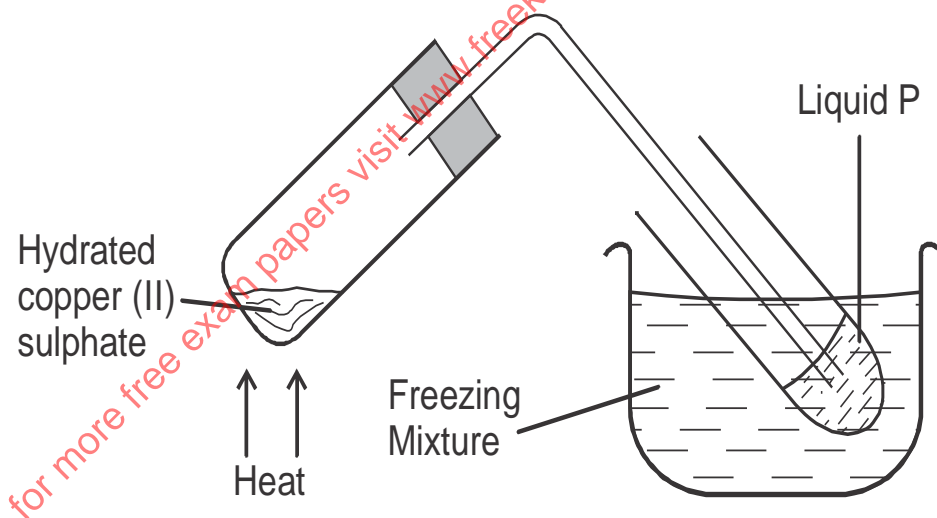

- i) State the colour change that occurred in the copper (II) sulphate crystals when heated. (1 mark)
- ii) Identify liquid P (1 mark)
- iii) Describe the chemical test that could be used to confirm liquid P. (2 marks)
- iv) Name the type of change that took place in the above set up. (1 mark)
- v) State two characteristics of the type of change named above. (1 mark)

b) The diagram below is a set up for the laboratory preparation of dry oxygen gas.

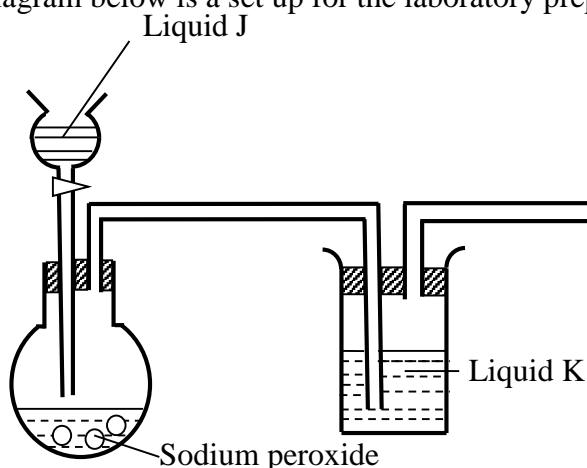

- i) Name:
- I. Liquid J..... (1mark)
- II. Liquid K..... (1mark)
- (ii) Write an equation for the reaction that took place in the flask. (1mark)
- (iii) Complete the diagram to show how dry oxygen can be collected (1mark)

LAINNAKU 1 JOINT EVALUATION - 2020

233/3

CHEMISTRY

PAPER 3

CONFIDENTIAL

In addition to the apparatus and fittings found in the laboratory, each student will require the following:

1. About 100cm³ of solution K
2. About 100cm³ of solution N
3. About 70cm³ of solution M
4. 1 pipette
5. 1 burette
6. 3 conical flasks (250ml)
7. A 250ml volumetric flask
8. 1 thermometer (-10° C to 110°C)
9. 8 test tubes
10. 1 boiling tubes
11. 10ml measuring cylinder
12. 100ml plastic beaker
13. 7 labels
14. a test-tube holder
15. Solid Q (about 0.5g)
16. Solid Z (about 0.5g)
17. Glass rod
18. Metallic spatula
19. Solid sodium hydrogen carbonate (about 0.2g)
20. 500 ml distilled water in a wash bottle

Access To:

1. Bunsen burner
2. methyl orange indicator supplied with a dropper

CHEMISTRY PAPER 1,2 & 3

3. Bromine water supplied with a dropper
4. 2M sodium hydroxide supplied with a dropper
5. Aqueous Barium nitrate supplied with a dropper
6. 2M Nitric (v) acid supplied with a dropper
7. Acidified potassium manganate (vii) supplied with a dropper.

NB:

- a) Solution K is prepared by dissolving 55ml of concentrated sulphuric (VI) acid in one litre of solution.
- b) Solution N is prepared by dissolving 8g of anhydrous sodium carbonate in one litre of solution
- c) Sodium M is prepared by dissolving 80g of sodium hydroxide in one litre of solution.
- d) Bromine water is prepared by dissolving 1cm³ of 20 volumes bromine water in 100cm³ of solution.
- e) Acidified potassium manganate (VII) is prepared by dissolving 3.16g of KMnO₄ in 600cm³ of 2MH₂SO₄ and made to one litre solution.
- g) Barium nitrate solution is prepared by dissolving 0.05g in one litre of solution.
- h) 2M bench reagent of Sodium hydroxide is prepared by dissolving 80g of sodium hydroxide in one litre of solution.
- i) Nitric (v) acid is prepared by dissolving 126ml of the stock acid in one litre of solution.
- j) Solid Q = Hydrated sodium carbonate
- k) Solid Z = Maleic acid.

LAINNAKU

233/3

CHEMISTRY PRACTICAL

1. You are provided with:

- You are provided with Aqueous sulphuric (VI) acid, solution **K**
- Solution **N** containing 4.0g of anhydrous sodium carbonate in 500 cm³ of the solution.
- An aqueous solution of substance **M**, solution **M**

You are required to determine the;

I) Concentration of solution **K**.

II) Enthalpy of reaction between sulphuric (VI) acid and substance **M**.

Procedure A

Transfer 25.0cm³ of the solution **K** into 250 ml volumetric flask using a pipette. Add water to make a 250cm³ of solution. Label this as solution **W**. Place solution **W** in a burette.

Clean the pipette and use it to place 25.0cm³ of solution **N** into a clean conical flask. Add 3 drops of methyl orange indicator provided and titrate with solution **W**. Record your result in table I below. Repeat the titration two more times and complete the table I below.

Table I

(4marks)

	I	II	III
Final burette reading (cm ³)			
Initial burette reading (cm ³)			
Volume of solution W used (cm ³)			

a) Calculate the:

- Average volume of solution **W** used
(1mark)
- Concentration of sodium carbonate, solution **N** in moles per Litre (Na=23, C=12, O=16)
(1mark)
- Concentration of sulphuric (VI) acid in solution **W** in moles per litre
(2marks)
- Concentration of Sulphuric (VI) acid in solution **K** in moles per litre
(1mark)

PROCEDURE B

- Label six test tubes as 1, 2,3,4,5, and 6. Using a measuring cylinder, place 2cm³ of solution **K** into test tube number 1, 4cm³ in test tube number 2. Continue with this process for all the other test tubes as shown in **table II** below.

- Clean the burette and fill it with solution **M**. From the burette, Place 14cm³ of solution **M** into a 100ml plastic beaker. Measure the initial temperature of this solution and record it in the **table II** below as T₀. Add the content of test tube number 1 to the plastic beaker containing solution **M**. Stir the mixture with thermometer and record the highest temperature reached in table II below as T₁. Repeat the process with the other sample of solution **M** given in the table II and complete the table.

Table II

(4marks)

Test tube number	1	2	3	4	5	6
Volume of solution K (cm ³)	2	4	6	8	10	12
Volume of solution M (cm ³)	14	12	10	8	6	4
Highest temperature of mixture T ₁ (°C)						
Initial temperature of solution M T ₀ (°C)						
Change in temperature , ΔT (°C)						

- On the grid below, draw a graph of ΔT (vertical axis) against volume of solution **K** (3marks)
- From the graph, determine;

CHEMISTRY PAPER 1,2 & 3

- (i) The maximum change in temperature (2 marks)
 (ii) The volume of K required to give the maximum change in temperature (1mark)

(c) Calculate the

- i. Number of moles of sulphuric (VI) required to give the maximum temperature change. (1mark)
 - ii. Molar enthalpy of reaction between sulphuric (VI) acid and substance M in kilojoules per mole of sulphuric (VI) acid. (Specific heat capacity = 4.2J/g/k, density of solution = 1.0g/cm³) (2marks)
2. You are provided with solid Q Carry out the tests below and write your observation and inferences in the spaces provided.

a) Place about third of solid Q into a dry, clean test tube .Heat gently and then strongly.

ii) Dip one end of a **clean** glass rod into the 2nd portion and put it on a non-luminous flame. **RETAIN** this portion to be used in part (iii) that follows.

Observation

Inference

iii) a) To the 2rd portion **retained** in part (ii) above, add 3 drops of barium nitrate solution followed by about 1cm³ of dilute nitric (V) acid.

Observation

Inference

1mark

1mark

(iv) To the 3rd portion, add 4 drops of acidified potassium dichromate (VI)

Observation

Inference

1mark

1mark

3 You are provided with solid Z .Carry out the tests below and record your observations and inference in the spaces provided.

a) Using a clean metallic spatula place about one third of the solid Z on a non-luminous Flame.

Observation

Inference

1mark

1mark

b) Place all the remaining solid Z in a clean boiling tube. Add about 8cm³ of distilled water and shake until the solid dissolves. Divide the mixture obtained into 3 portions.

(i) To the 1st portion, add all solid sodium hydrogen carbonate provided.

CHEMISTRY PAPER 1,2 & 3

Observation

Inference

1mark

1mark

(ii) To the 2nd portion, add 3 drops of acidified potassium manganate (VII) solution.

Observation

Inference

1mark

1mark

(iii) To the 3rd portion, add 4 drops of bromine water.

Observation

Inference

1mark

1mark

for more free exam papers visit www.freekcsepastpapers.com

CHEMISTRY PAPER 1,2 & 3
KIGUMO CLUSTER EXAM
CHEMISTRY
PAPER 1

1. Describe two observable characteristic of a luminous flame (2mks)
 2. Study the table below to answer the question that follows

SOLUTION	A	B	C	D
PH VALUE	13.5	2.2	7.2	6.5

- (i) Which solution is likely to be?
 (a) Potassium hydroxide (1mks)
 (b) Acid rain (1mks)
 (ii) A substance E reacted with both solution A and B .What it is the nature of substance E (1mks)
 3. Air was passed through several reagents as shown below

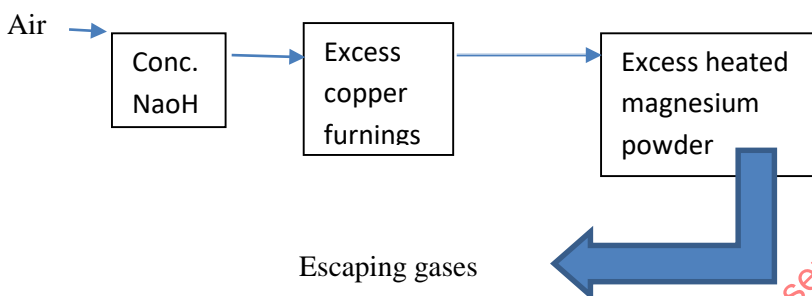

- (i) Name one gas which escapes from the chamber containing magnesium powder. Give a reason for your answer (2mks)
 (ii) Writes an equation for the reactions which takes place in the chamber containing magnesium powder (1mks)
 4. (a) A fixed mass of a gas occupies 200cm³ at a temperature of 23⁰ c and pressure of 780mm Hg. Calculate the volume of the gas at -25⁰c and 740mmHg (2mks)
 (b) What is the relationship between the rate of diffusion of a gas and its molecular mass? (1mks)
 5. An atom of elements Q has a mass number 39.and 19 protons
 (a) Write the electron arrangements of the Atom (1mks)
 (b) State whether the elements is a metal or a non-metal (1mks)
 (c) State the period and group to which elements Q belongs
 Group:..... (1/2 mks)
 Period :..... (1/2mks)

6. The table shows properties of metal chloride X and Y

Chloride	Melting points (oc)	Electrical conductivity
X	203	Poor
Y	1070	Good

- a) State the type of bond present in:
 (i) X..... (1mks)
 (ii) Y..... (1mks)
 (a) Explain why Y conducts electricity while X does not in terms of structure and bonding (1mks)

7. The figure shows an apparatus used to separate a mixture of water and hexane



- (a) Name the apparatus shown (1mks)
- (b) State the principle by which the mixture of the two liquid is separated. (1mks)
- (c) Identify the liquids P and Q if the density of hexane is 0.54 g/cm^3
- (i) P..... (1 mk)
- (ii) Q (1mk)
- 8. 15 g of Zinc carbonate was strongly heated to a constant mass. Calculate the mass of the solid residue formed (Zn=65, C=12, O=16) (3mks)
- 9. Starting with copper metal describe how a sample of Copper (II) Sulphate can be prepared (3mks)

10. Complete the following table

Solution	Nature of solution	PH value
A	Strong acid	_____
B	_____	14
C	Neutral	_____
D	_____	8.5

(2mks)

11. The flow chart shows the process that occurs in the manufacture of nitric (v) acid

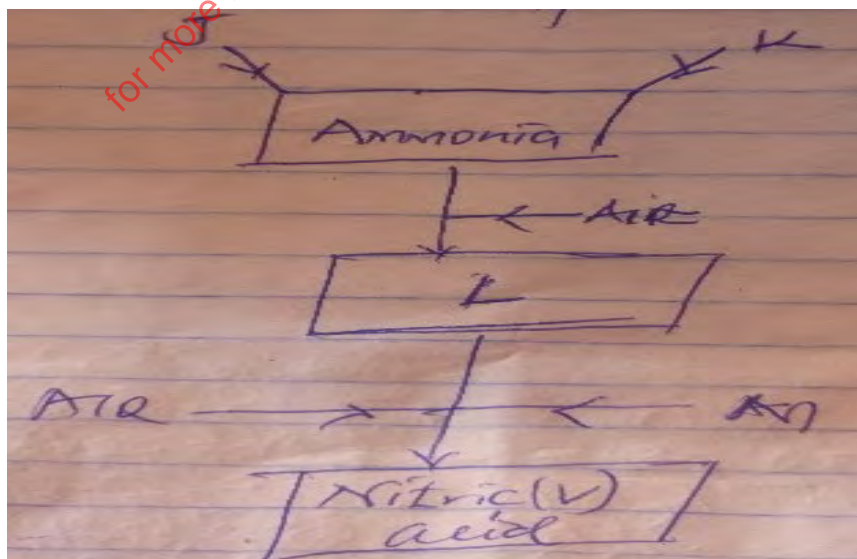

CHEMISTRY PAPER 1,2 & 3

Name substances

(i) (J).....

(1mks)

)

(ii)(K)

(1mks)

)

(iii) (l).....

(1mks)

12. The figure below shows two gas Y and Z diffusing from opposite ends 18 seconds after the experiments

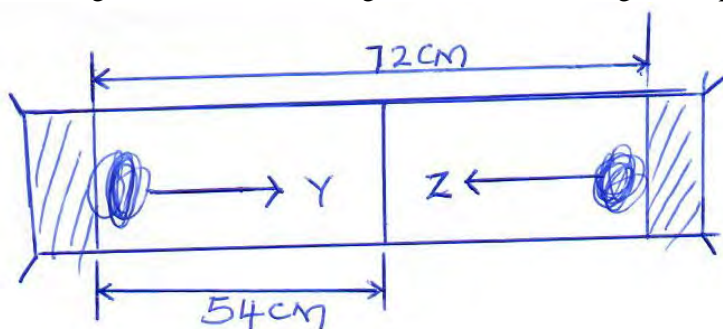

(a) Which of the gases has a lower density

(1mks)

)

(b) Given the molecular mass of gas Z is 17, calculate the molecular mass of Y

(2mks)

13. The set-up below is used to prepare dry sulphur (IV) oxide in the laboratory. Answer questions that follows

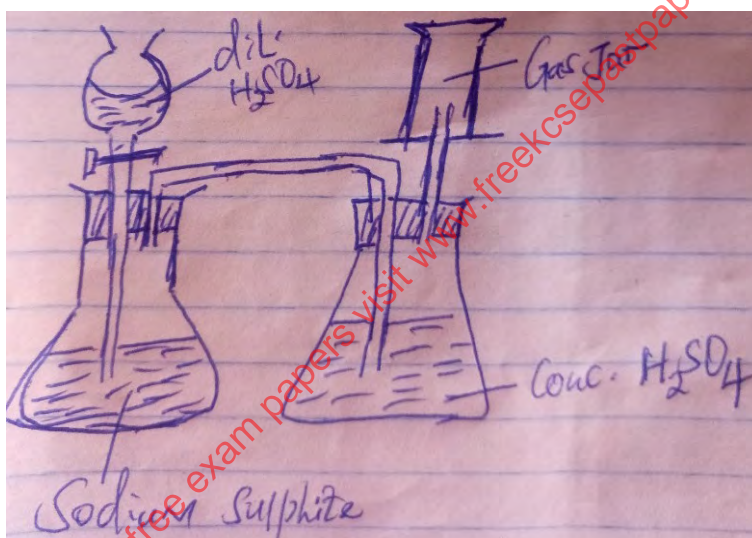

(a) Identify the mistakes in the set-up

(1mks)

)

(b) State how the polluting effects of the gas on the environments can be controlled

(1mks)

(c) Write an equation for the reaction in the set-up

(1mks)

14. (a) State two properties that vulcanized rubber possess as a results of vulcanization

(1mks)

)

(b) In an attempts to prepare Sulphur (IV) oxide gas ,Sulphuric (VI) acid was reacted with barium carbonate .The yield of Sulphur (IV)oxide was found to be negligible .Explain

(2mks)

15. Name the following compound of organic compounds

(a) $\text{CH}_3\text{C}(\text{CH}_3)\text{C}(\text{CH}_3)\text{CH}_3$

(1mk)

(b) $\text{CH}_3\text{CH}(\text{CH}_3)\text{CH}_2\text{CH}(\text{CH}_3)\text{CH}_3$

(1 mks)

)

16. The figure below is part of a set –up used to prepare and collect dry carbon (ii)oxide from carbon (iv) oxide

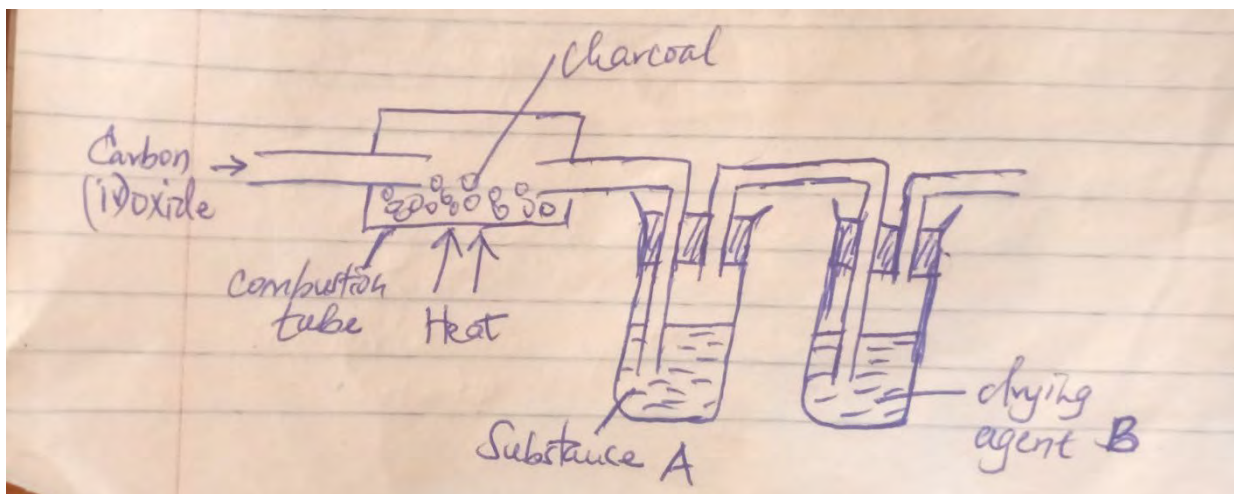

- (a) Complete the diagram to show how dry carbon (ii) oxide is collected (1mks)
 - (b) Identify (i) Dry Agents B (1mks)
 - (ii) State the use of substance A (1mks)
17. (a) Define the term molar enthalpy of displacements of an elements . (1mks)
- (b) During a displacements reaction, excess iron powder was added to 25cm³ of 0.5 M copper (ii) sulphate solutions. The temperature rose from 18.5°C to 33.0°C. Calculate the molar enthalpy of displacements of copper.(Density of the solution =1.0 g/cm³, specific heat capacity is 4.18J/g/K) (2mks)
18. Study the flow chart below and answer the question that follows

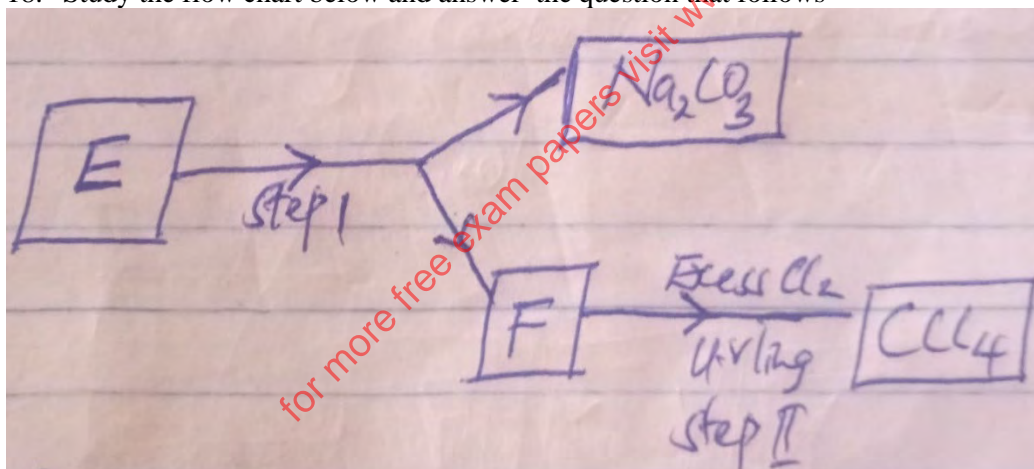

- (a) Identify F :..... (1mks)
 - E :..... (1mks)
19. The grid below is a section of the periodic table. The letters do not represent the actual symbol of the elements. Use it to answer the questions that follow;

			K
C		F	H
D	E		G I

- (i) Write an electron arrangement of the ion E^{2+} . (1mk)
 (ii) How does the electronegativity vary from H to J? (1mk)
 (iii) Give the formula of the compound between E and J. (1mk)
20. 8g of sodium carbonate were allowed to react with 25cm³ of 0.4M Sulphuric (VI) acid until there was no further reaction. Calculate the mass of the unreacted sodium carbonate. (3mks)
21. (a). What is fractional crystallization? (1mk)
 (b) The solubility of Copper (II) Sulphate is 55g/100g of water at 75^oc. What mass of crystals would be deposited, if 150g of a saturated solution is cooled from 75^oc to 15^oc? (2mks)
22. The diagram below was used to electrolyze molten zinc (II) chloride using graphite electrode.

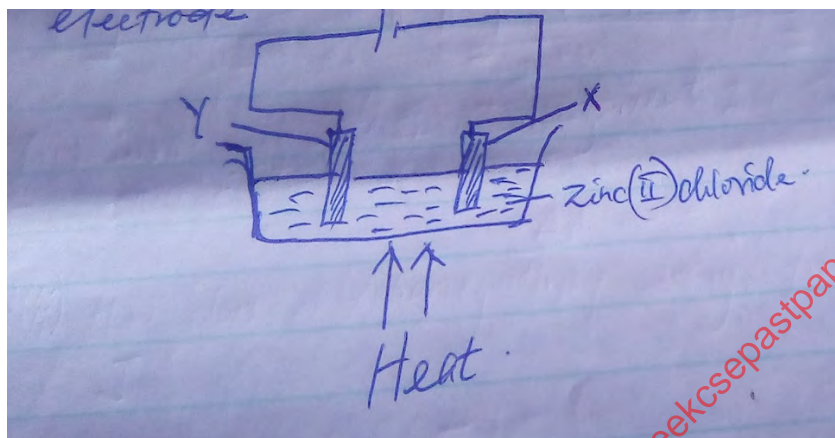

- (i) Explain the role of heat on the above set-up. (1mk)
 (ii) Name electrode X and Y:
 X: _____ (1mk)
 Y: _____ (1mk)
- (iii) Write an equation for the reaction occurring at electrode Y. (1mk)
23. Zinc reacts with hydrochloric acid according to the following equation

$$Mg_{(s)} + 2HCl_{(aq)} \longrightarrow MgCl_{2(aq)} + H_{2(g)}$$
- (a) Identify the reducing. Give a reason for the answer. (2mks)
 (b) Iron sheets are dipped in molten zinc to prevent rusting. Name the process. (1mk)
24. A crystal of iodine was heated in a boiling tube to give off a purple vapour.
 (a) What type of bond is broken the iodine crystal is heated gently? (1mk)
 (b) Write the formulae of the substance responsible for the purple vapour. (1mk)
 (c) State one use of iodine. (1mk)
25. The table below gives the number of electrons; protons and electrons in elements A, B and C. study it and answer the questions that follow.
- | Element | Protons | Neutrons | Electrons |
|---------|---------|----------|-----------|
| A | 10 | 10 | 10 |
| B | 8 | 10 | 10 |
| C | 8 | 8 | 8 |
- (a) Which letter represents an ion? (1mk)
 (b) Which of the elements are isotopes? Give a reason. (2mks).
26. Carbon (IV) oxide, methane, nitrogen (I) oxide and trichlorofluro methane are green-house gases.
 i. Give one source from which each of the following gases is released to the environments
 (a) Methane (1mks)

CHEMISTRY PAPER 1,2 & 3

- (b) Trichlorofluoromethane (1mks)
27. Under certain condition ,hexane can be converted to two products .The formula of one of the products is C_3H_8
- (i) Write the formula of the other products (1mks)
- (ii) Describe a simple chemical test to show the difference between the two products formed in (i) above (2mks)
28. The table shows how solubility of some substance s in water varies with temperature.
- 29.

Substance	Change of solubility with temperature $g/100cm^3$ of water			
	$0^{\circ}c$	$20^{\circ}c$	$40^{\circ}c$	$60^{\circ}c$
P	0.334	0.16	0.097	0.0058
Q	27.60	34.0	40.0	45.5
R	35.70	36.0	36.6	37.3

Which of the above gas substances is likely to be a gas? Explain (2mks)

KIGUMO CLUSTER EXAM

233/2

Chemistry

Paper 2

1. I) One mole of Heptane was thermally cracked, two hydrocarbons Q and P were formed. Q was alkene molecule with three carbon atoms.
- (a) Draw the structural formula of the hydrocarbons.
- Q (1mk)
- P (1mk)
- (b) Name the compounds that can be used to prepare Ethene in the laboratory. (1mk)
- (c) Name the compound formed when Q undergoes self-addition reaction. (1mk)
- d) i State one disadvantage of using the product named in (c) above. (1mk)
- ii) An organic compound J has the following percentage by mass, carbon, 64.86%, hydrogen, 13.51% and the rest oxygen. The relative molecular mass of the compound is 74. [C=12. H=1 O=16]
- a) Work out the molecular formula of compound J. (3mks)
- b) To which homologous series does compound J belong? (1mk)
- c) Write a balanced chemical equation for the reaction that occurs when compound J reacts with sodium metal. (1mk)
- d) Name the type of reaction indicated in (c) above. (1mk)
- e) (i) Name the organic compound formed when compound J reacts with excess acidified potassium manganate (VII). (1mk)
- ii) State the observation made in (e) (i) above. (1mk)

2. (A) The table below gives information about some oxides. Study the information and use it to answer the questions that follow.

Formula of oxide	Melting point(°c)	Effect of adding water to oxide	Effect of electric current on molten oxide	Effect of adding aqueous sodium hydroxide to oxide
Na ₂ O	920	Dissolves readily	Conducts; Na (s) and O ₂ (g) produced	(a)
P ₂ O ₅	563	Dissolves readily	(b)	(c)
SO ₃	17	Dissolves readily	Does not conduct	Reacts readily
Al ₂ O ₃	2045	Does not dissolve readily	(d)	Reacts readily

- i. Write the missing information for spaces **a to d** (2mks)
 - ii. Write equations for the reactions that take place between
 - a) SO₃ gas and water (1mk)
 - b) SO₃ gas and sodium hydroxide (1mk)
 - iii. Why is it not advisable to carry out reaction ii (a) above in the laboratory? (1mk)
 - iv. Explain the difference in the melting points of P₂O₅ and SO₃ (1mk)
 - v. Phosphorous (V) oxide dissolves in water to form phosphoric acid. State and explain how the ability of concentrated phosphoric acid to conduct electricity compares to that of dilute phosphoric acid (2mks)
- (B) During the industrial manufacture of hydrochloric acid, hydrogen gas and chlorine gas are the raw materials.
- i. Write an equation for the reaction that occurs between hydrogen and chlorine in the burning chamber (1mk)
 - ii. What is the purpose of the glass beads in the absorption chamber after the reaction between chlorine and hydrogen? (1mk)
 - iii. Given that the percentage purity of the hydrochloric acid manufactured is 35% and its density is 1.18g/cm³ determine the concentration of the acid. (H=1, Cl=35.5) (2mks)

3. The diagram below shows a set up used to prepare salt X

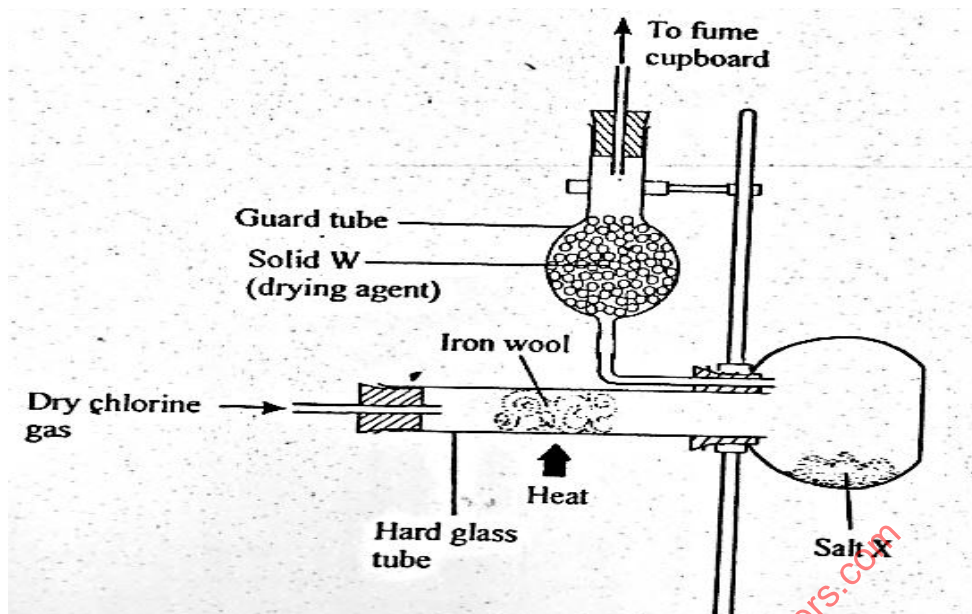

- (a) Write an equation for the reaction that occurs in the glass tube. (1 mark)
- (b) Give a reason why salt X is collected far away from where it is formed. (1 mark)
- (c) Name a suitable drying agent that can be used as solid W. (1 mark)
- (d) Give a reason why the experiment should be carried out in a fume chamber. (1 mark)
- (e) 1.2g of salt X was formed in the flask. Calculate the total volume of chlorine gas that reacted at s.t.p (Fe = 56, Cl = 35.5, molar gas volume at s.t.p = 22.4dm³) (3 marks)

4. The table below shows the solubility of Nitrogen (IV) oxide at different temperatures.

Temperature °C	5	10	20	30	40	50	60	70
Solubility of Nitrogen IV oxide in g/1000cm ³ of water	150	116	84	60	37	22	14	10

- a) (i) On the grid provided plot a graph of solubility of Nitrogen (IV) oxide in g/1000cm³ of water against temperature. (3mks)
- b) From the graph determine: -
- i) Temperature at which 1000cm³ of solution would contain 48g of Nitrogen IV oxide. (1mk)
- (ii) Maximum mass of nitrogen IV oxide that would dissolve in 40litres of solution at 25°C. (2mks)
- c) Potassium hydroxide reacts with Nitrogen (IV) oxide according to the equation below.
- $$2\text{KOH}_{(aq)} + 2\text{NO}_2(g) \rightarrow \text{KNO}_3(aq) + \text{KNO}_2(aq) + \text{H}_2\text{O}(l)$$
- i) Using the information in the graph, determine the volume of 2M potassium hydroxide required to completely neutralize one litre of saturated solution of Nitrogen(IV) oxide at 18°C (N=14 O=16) (2mk)
- ii) Name the process that can be used to separate the two salts in (c) above. (1mk)
- d) In industrial manufacture of Nitric (V) acid, Nitrogen (IV) oxide is absorbed in water in presence of excess air.
- i. Explain why it is not advisable to use hot water in this process. (1mk)
- ii. Write a balanced equation for the industrial manufacture of Nitric (V) acid. (1mk)
- e) i) Name a device that is fitted into car exhaust to minimize emission of Nitrogen (IV) oxide into air. (1mk)
- ii) What is the environmental effect of presence of Nitrogen (IV) oxide in air? (1mk)

5. a) The grid below represents part of the periodic table. Study the information and answer the questions that follow. The letters do not represent the actual symbol of the elements.

- Which element would form a trivalent cation? (1mk)
 - Write the equation for the reaction that would occur between **E** and **Y** (1mk)
 - Which elements belong to the region labeled **W**? (1mk)
 - Which is the most reactive non-metallic element in the table above? Explain (2mks)
 - How does the atomic radius of **T** compare with that of **Y** (2mks)?
- c) The table below shows some properties and electronic arrangements of common ions of elements represented by letters **D** to **K**. Study the information and answer the questions that follow>

Element	Formula of ion	Ionic electronic arrangement	Atomic radius (nm)	Ionic radius (nm)
D	D ⁻	2.8	0.072	0.136
E	E ⁺	2.8.8	0.231	0.133
F	F ³⁺	2.8	0.143	0.050
G	G ²⁺	2.8.8	0.133	0.074
H	H ²⁺	2.8	0.160	0.064
I	I ⁺	2.8	0.186	0.095
J	J ³⁻	2.8.8	0.110	0.190
K	K ⁻	2.8.8	0.099	0.181

- State the atomic numbers of elements **F** and **G** (1mk)
- Select two metals that belong to period 3 (1mk)
- Element **I** reacts violently with water. Write the equation for the reaction (1mk)
- Why is the ionic radius of **G** smaller than its atomic radius (1mk)
- Compare and explain the reactivity of **G** and **H** (2mks)

6. Read the following passage and answer the questions.

A salt K was heated with slaked lime (calcium hydroxide). A colourless gas L with a characteristic smell was evolved. A large quantity of this gas was passed through an inverted filter funnel into water, and a colourless solution M was obtained. M was treated with an equivalent volume of dilute Sulphuric(VI) acid and the resulting solution was evaporated. A white solid N was obtained.

- Identify gas L (1 mk)
- What is K most likely to be? (1 mk)
- Write an equation for the reaction between K and slaked lime (1 mk)
- Explain why gas L is passed into water through an inverted funnel (2 mks)
- identify M and N (1 mk)
 - Write an equation for the reaction between M and Sulphuric(VI) acid (1 mk)
- In industry, the gas L is obtained by direct combination of two gases D and E, by passing them over a catalyst F at 450°C and high pressure
 - Name the gases D and E (2 mks)
 - Name the catalyst F (1 mk)
 - Write an equation for the reaction between the gases D and E (1 mk)
 - Copper (II) oxides were heated in a pure sample of gas L. State and explain the observation you would make (2 mks)

7. The set up below was used to prepare dry hydrogen chloride gas and investigate its effects on heated iron fillings.

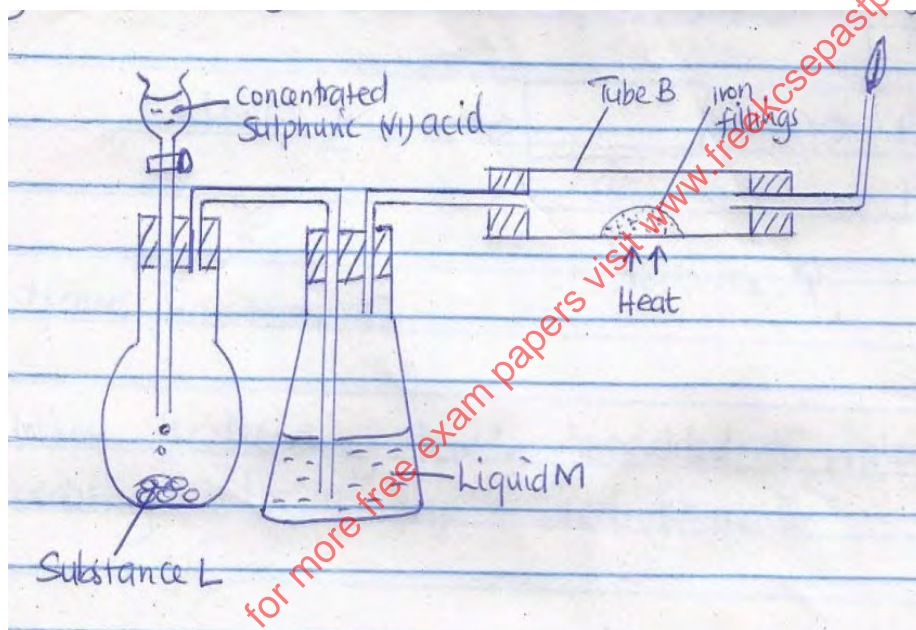

- Name substance L (1mk)
 - Name Liquid M (1mk)
 - What will be observed in tube B? (1mk)
 - Write an equation for the reaction that occurs in tube B. (1mk)
 - Why is the gas from tube B burnt? (1mk)
- b) i) Explain the following observations.
- A white precipitate is formed when hydrogen chloride gas is passed through aqueous silver nitrate. (1mk)
 - Hydrogen chloride gas fumes in ammonia gas. (1mk)
- ii) State two uses of hydrogen chloride gas. (2mk)

CHEMISTRY CONFIDENTIAL.

- 15cm³ solution K
- 90.0cm³ Solution M
- 150 cm³ solution N
- Burette
- Pipette
- Conical flask
- 100ml measuring cylinder
- 10ml measuring cylinder
- 250ml beaker
- 1 Label
- About 1g magnesium sulphate
- 6 test tubes in a rack
- Boiling tube
- About 1g solid Q
- About 1g sodium carbonate
- Distilled water in a wash bottle
- Access to
- Means of heating
- Test tube holder
- 2M sodium hydroxide in a beaker
- 2M ammonia solution in a beaker
- Acidified barium nitrate in a beaker
- Acidified potassium manganate (VII) in a beaker
- Acidified potassium dichromate (VI) in a beaker
- Phenolphthalein indicator
- Bromine water

NB

Solution K is 1M HCl

Solution M is 0.05M oxalic acid

Solution N is 0.1M sodium hydroxide

KIGUMO

233/3

CHEMISTRY

PAPER 3

PRACTICAL

1. You are provided with

- Solution **K** HCl
- Solution **M** made by dissolving 1.575g of a dibasic acid, H₂C₂O₄.2H₂O in 250cm³ of solution
- Solution **N** sodium hydroxide solution

You are required to

- a) Standardize sodium hydroxide using the dibasic acid
- b) Use the standardised sodium hydroxide to determine the molarity of **K**

Procedure 1

Fill the burette with M. Pipette 25.0 cm³ of N into a conical flask. Carry out titration using phenolphthalein indicator. Record your results in the table below. Repeat the procedure to obtain consistent results

TITRATION	1	2	3
-----------	---	---	---

Final burette reading (cm³)Initial burette reading (cm³)Volume of **M** used (cm³)

(4mks)

a) Calculate

(i) The average titre volume of **M** used

(1mk)

(ii) The concentration of the dibasic acid in moles per litre. (C=12,H=1,O=16)

(1mk)

(iii) The molarity of sodium hydroxide

(2mks)

Procedure 2

Using a measuring cylinder measure 90cm³ of distilled water and place it in a 250cm³ beaker. Add 10cm³ of solution **K** and shake. Label the mixture **S**. Fill the burette with **S**. Pipette 25cm³ of solution **N** into a clean conical flask. Carry out titration using phenolphthalein indicator. Record your results in the table below.

Titration	1	2	3
-----------	---	---	---

Final burette reading (cm³)Initial burette reading (cm³)Volume of solution **S** used (cm³)

(4mks)

b) Calculate

(i) The average titre volume of solution **S** used

(1mk)

(ii) The molarity of **S**

(2mks)

(iii) The concentration of the original HCl (solution **K**) in moles per litre.

(2mk)

2. You are provided with solid **K** suspected to be Magnesium sulphate.a) Using the reagents given below describe 3 consecutive tests that can be done to confirm the identity of **K**.

- Sodium hydroxide solution
- Ammonia solution
- Acidified barium nitrate solution
- Distilled water

Test 1	Expected observation
2mk	1mk

Test 2	Expected observation
1mk	1mk

Test 3	Expected observation
1mk	1mk

b) Using the reagents provided perform the tests you have described above and record your observations and inferences in the spaces provided

observations	inferences
1mk	1mk

observations	inferences
1mk	1mk

observations
1mk

inferences
1mk

3. You are provided with solid Q. Carry out the test below and record your observations and inferences in the spaces provided.

Place all solid T in a boiling tube. Add 10cm³ of distilled water and shake.

Observations
1mk

inferences
1mk

Divide the resulting mixture into 4 portions.

a) To the first portion add acidified potassium Manganate (VII) and warm

Observations
1mk

inferences
1mk

b) To the second portion add acidified Potassium dichromate (VI) and warm

observations
1mk

inferences
1mk

c) To the third portion of solution add 2 drops of bromine water

observations
1mk

inferences
1mk

d) To the fourth portion add half a spatula end full of sodium carbonate

observations
1mk

inferences
1mk

for more free exam papers visit www.thekcsepastpapers.com

CHEMISTRY PAPER 1,2 & 3
MERU CENTRAL CLUSTER EXAMS
233/1
CHEMISTRY
PAPER 1
(THEORY)

- The electronic arrangement of ions x^{3+} and y^{2-} are 2.8 and 2.8.8 respectively
 - Write the electronic arrangement of the elements x and y. (3 marks)
 - Write the formula of the compound that would be formed between x and y. (1 mark)
- When bromine gas reacts with aqueous Sodium hydroxide, the equilibrium represented by the equation;

$$\text{Br}_2(\text{aq}) + 2\text{OH}^-(\text{aq}) \rightleftharpoons \text{Br}^-(\text{aq}) + \text{OBr}^-(\text{aq}) + \text{H}_2\text{O}$$
 is established.

What observations would be made if a few drops of sulphuric (VI) acid were added to the equilibrium mixture? (2 marks)

- Calculate the amount of calcium carbonate that would remain if 15.0g of calcium carbonate were reacted with 0.2g moles of hydrochloric acid. The equation for the reaction is,

$$\text{CaCO}_3(\text{s}) + 2\text{HCl} \longrightarrow \text{CaCl}_2(\text{aq}) + \text{CO}_2(\text{g}) + \text{H}_2\text{O}(\text{l})$$
 (C = 12.0, O = 16, Ca = 40.0) (3 marks)
- In an experiment, soap solution was added to three separate samples of water. The table below shows the volumes of soap solution required to form lather with 1000cm³ of each sample of water before and after boiling.

	Sample 1	Sample 2	Sample 3
Volume of soap before water is boiled	27.0	3.0	10.6
Volume of soap after water is boiled	27.0	3.0	3.0

- Which water sample is likely to be soft? Explain. (2 marks)
 - Explain the change in the volumes of soap solution used in sample (iii). (1 mark)
- Ammonia gas was passed into water as shown.

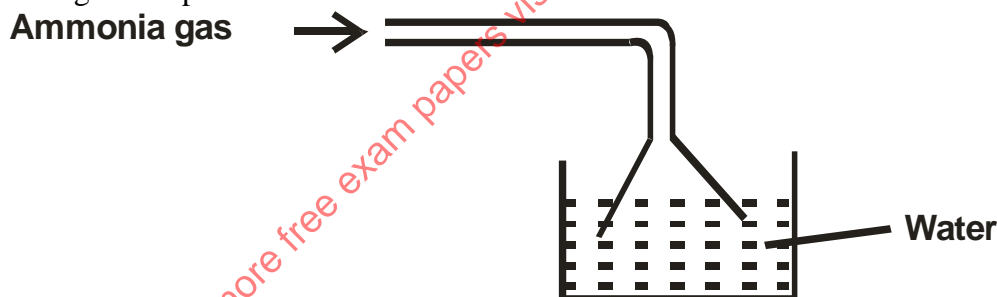

- When a red litmus paper was dropped into the resulting solution, it turned blue. Give a reason for this observation. (1 mark)
 - What is the function of the funnel? (1 mark)
- The table below gives some properties of gases D and E.

Gas	Density	Effects of H ₂ SO ₄	Effects of NaOH
D	Lighter than air	Reacts to form a salt	Dissolves without reacting
E	Heavier than air	Not affected	Not affected

 - Describe how you would obtain a sample of E from a mixture of gases D and E. (2 marks)
 - Suggest a possible identity of gas D. Give a reason for your answer. (1 mark)

7. The curve below represents the variation of temperature with time when pure and impure samples of a solid were heated separately.

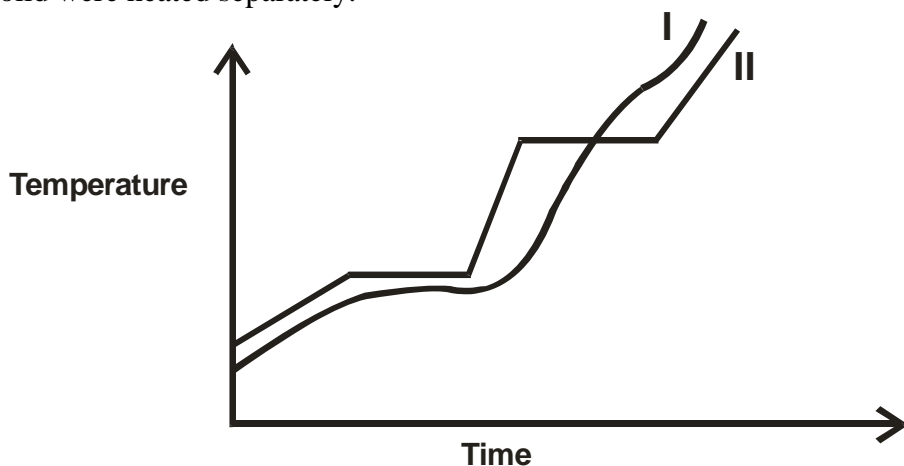

Which curve shows the variation in temperature for the pure solid? Explain. (2 marks)

8. The diagram below represent set-up that can be used to prepare and collect oxygen gas.

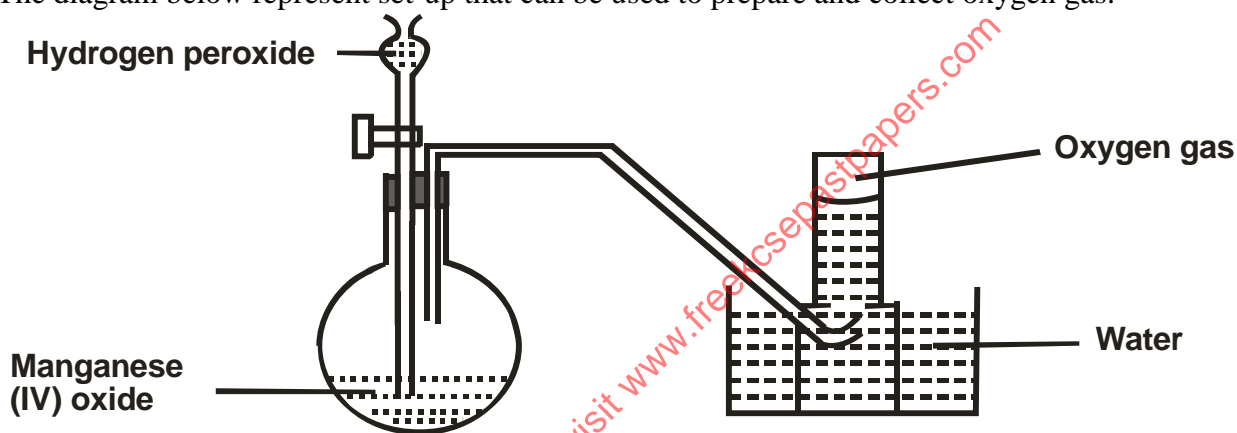

- a) Write an equation for the reaction that takes place. (1 mark)
- b) What property of oxygen makes it possible for its collection as indicated by the diagram? (1 mark)
- c) Explain why it is important not to collect gas for the first few seconds of the experiment. (1 mark)

9. Study the set-up below and answer the questions that follow.

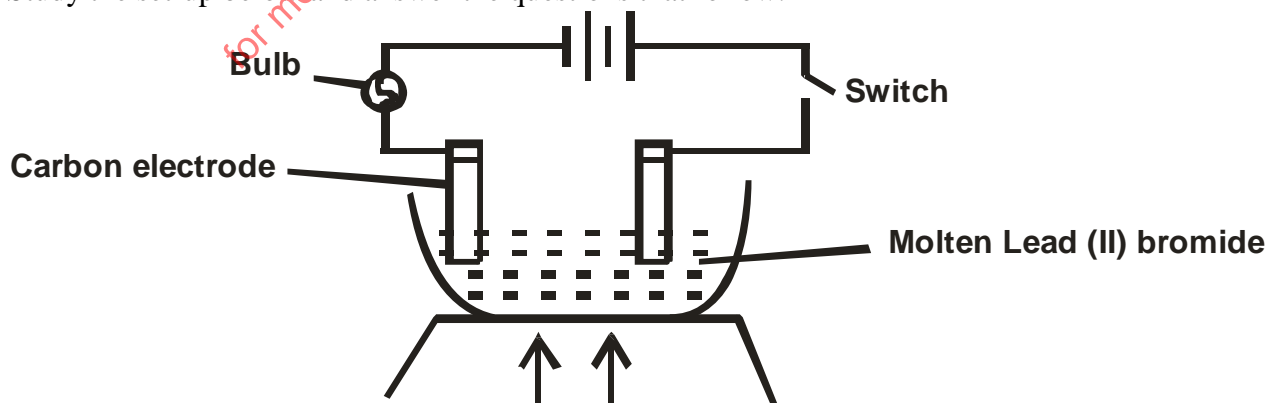

State and explain the observation that would be made when the circuit is completed. (3 marks)

CHEMISTRY PAPER 1,2 & 3

10. In an experiment, rods of metals P, Q and R were cleaned with sand paper and placed in a beaker containing water. Another set of rods was also cleaned and placed in a beaker containing dilute acid. After placing the rods in the two liquids, bubbles of gas were seen around some of the rods as shown in the diagrams below.

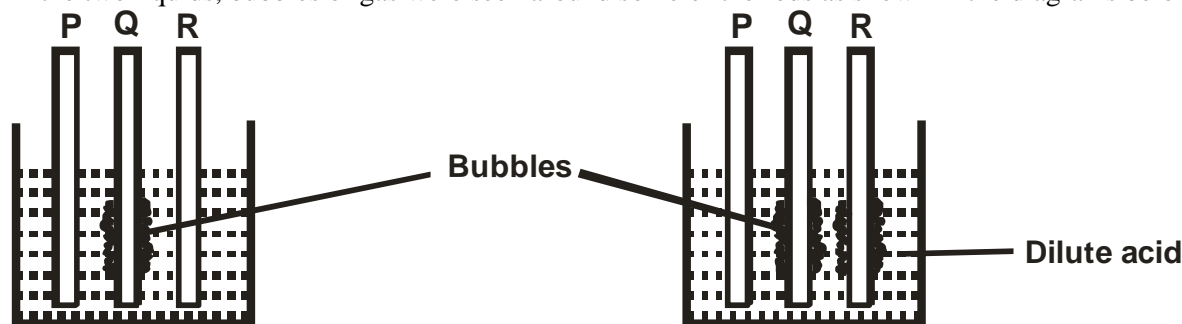

- a) Why is it necessary to clean the rods with sand paper before dipping them into the liquids? (1 marks)
- b) Arrange the three metals in order of their reactivity starting with the most reactive. (1 mark)
11. A solution of chlorine in tetrachloromethane turns colourless when propene gas is bubbled through it.
- a) What type of reaction takes place? (1marks)
- b) Write an equation for the above reaction. (1 mark)
12. With reference to atomic number of one, explain why hydrogen can be placed in either group I and VII of the periodic table. (2 marks)
13. a) Define the term base. (1 mark)
- b) Explain why it is not advisable to use wood ash for cleaning aluminium utensils. (2 marks)
14. A compound has an empirical formula C_3H_6O and a relative formula mass of 116. Determine its molecular formula. (C = 12, O = 16, H = 1) (2 marks)
15. Explain how you would separate mixture of nitrogen and oxygen gases given that their boiling points are $-196^\circ C$ and $-183^\circ C$ respectively. (2 marks)
16. Study the table below and answer the questions that follow.

Alkaline	Formula	Heat of combustion (ΔH_c) $KJmol^{-1}$
Methane	CH_4	-890
Ethane	C_2H_6	-1560
Propane	C_3H_6	-2220
Butane		

- a) Predict the heat of combustion of Butane and write it on the space provided in the table above. (1 mark)
- b) What does the negative sign ΔH_c value indicate about combustion of alkanes? (1 mark)
17. The diagram below represents the extraction of sulphur by Frasch process.

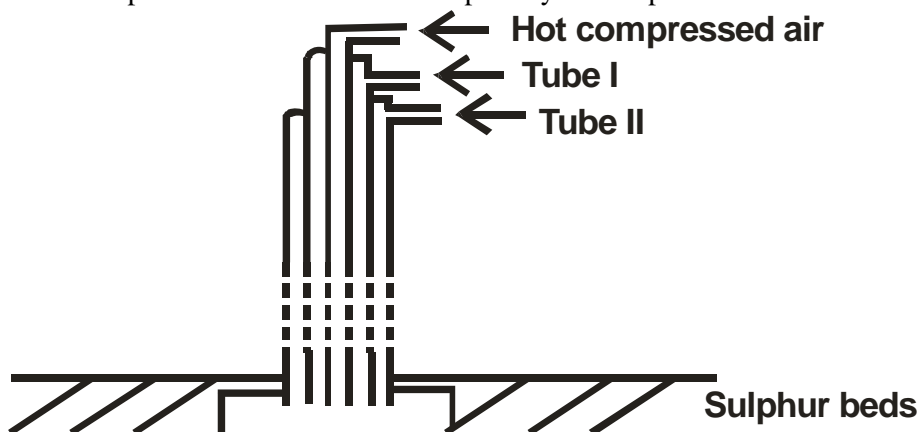

- a) Name the substance that passes through tube I and II. (2 marks)

b)

c) What is the purpose of hot compressed air in this process? (1 mark)

18. Study the diagram below and answer the questions that follow.

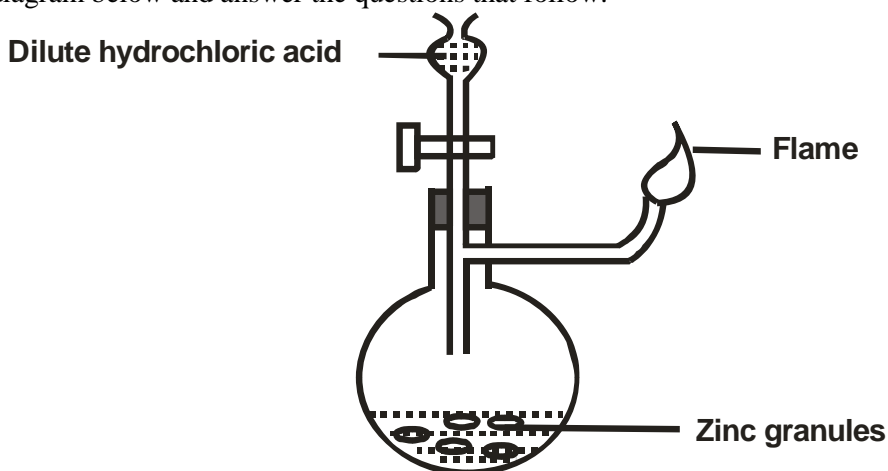

Write an equation for each of the two reactions that take place in the experiment represented by the diagram above. (2 marks)

19. A mixture containing equal volumes of hydrogen gas and carbon (IV) oxide gas was introduced on one end of a tube as shown below.

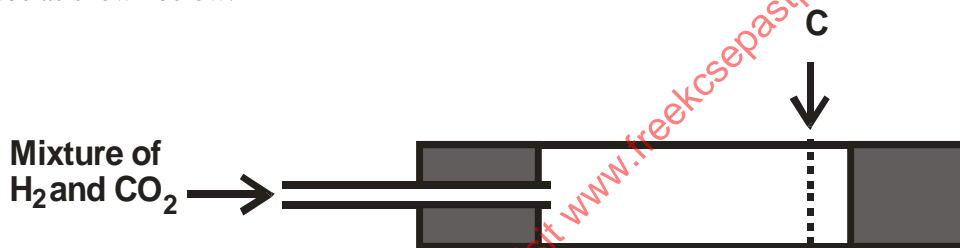

Which gas would be detected at point C first? Explain. (2 marks)

20. The table below gives three experiments on the reaction of excess sulphuric (VI) acid and 0.5 g of zinc done under different conditions. In each the volume of the gas was recorded at different time interval.

Experiment	Form of zinc	Sulphuric (VI) acid
I	Powder	0.8M
II	Powder	1.0M
III	Granules	0.8M

On the axis below draw and label the three curves that could be obtained from such results. (3 marks)

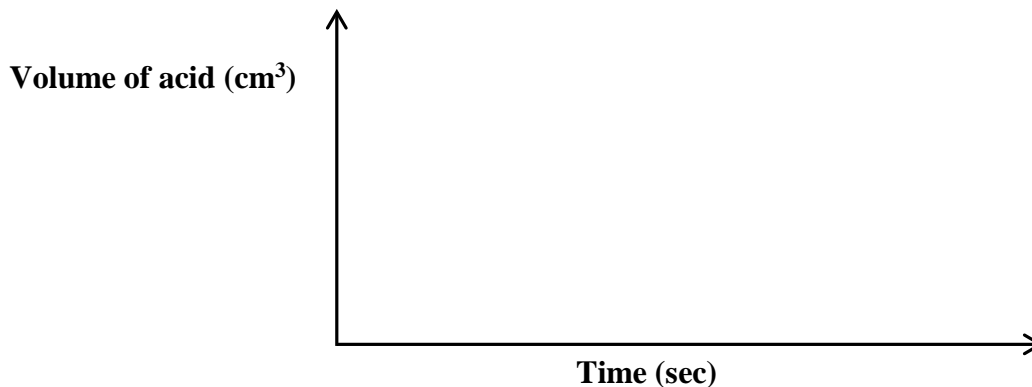

21. The table below shows how solubility of some substances in water varies with temperature

Substance	Change of solubility g/100cm ³ of water with temperature			
	0°C	20°C	40°C	60°C
W	0.334	0.16	0.097	0.0058
X	27.60	34.0	40.0	45.5
Y	35.70	36.0	36.6	37.3

Which of above substances is likely to be a gas? Explain.

(2 marks)

22. Study the chart below and answer the questions that follow.

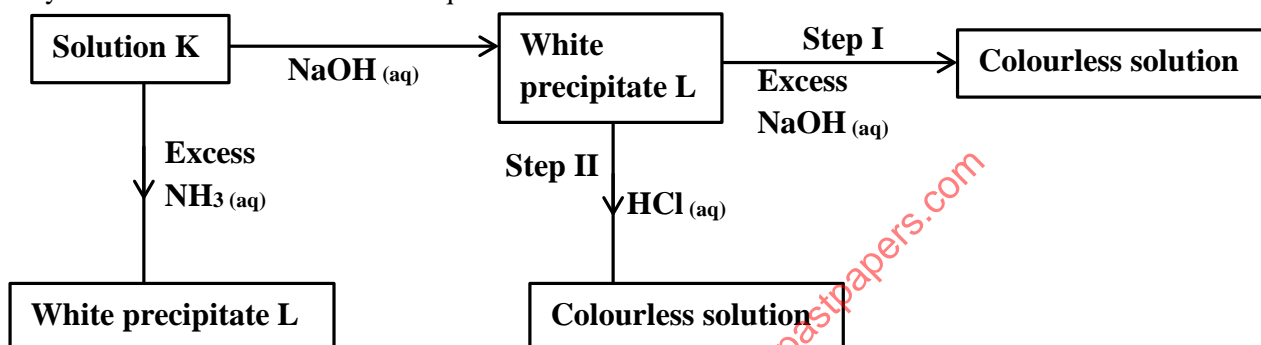

a) Identify;

i. the metal ions in solution K

(1 mark)

ii. the white precipitate L.

(1 mark)

b) What is the nature of solution K?

(1 mark)

23. Explain the following observation. A chloride dissolves in water to form an electrolyte while the same chloride dissolves in methylbenzene to form a non-electrolyte.

(2 marks)

24. State what would be observed when dilute hydrochloric acid is added to the products formed from a mixture of iron filings and sulphur.

(2 marks)

25. Describe how the following reagents can be used to prepare lead (II)sulphate; solid potassium sulphate, solid lead (II) carbonate, dilute nitric (V) acid and distilled water.

(2 marks)

26. Explain why the enthalpy of neutralisation of ethanoic acid with sodium hydroxide is different from that of hydrochloric acid with sodium hydroxide.

(2 marks)

27. Give a reason why calcium hydroxide solution is used to detect the presence of carbon (IV) oxide gas while sodium hydroxide solution is NOT.

(2 marks)

28. A compound C₂H₂ reacts with hydrogen in presence of nickel catalyst to form another compound C₂H₄. The same compound C₂H₂ reacts with hydrogen to form C₂H₆ in presence of nickel catalyst.

a) Draw the structural formula and name the compound C₂H₄.

(1 mark)

b) Write the equation for the reaction between C₂H₄ and hydrogen.

(1 mark)

29. During the production of hydrogen Iodide, hydrogen reacts with Iodine according to the equation.

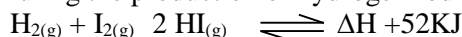

Explain how the following would affect the yield of hydrogen Iodide.

(2 marks)

a) Increase in temperature

b) Increase in pressure

30. a) Using dots (•) and crosses (x) to represent electrons, draw diagrams to represent the bonding in;

(2 marks)

i) NH₃

ii) NH₄⁺

b) State why an ammonia molecule (NH₃) can be combined with H⁺ to form NH₄⁺

(atomic numbers N = 7 and H = 1)

(1 mark)

CHEMISTRY PAPER 1,2 & 3

31. The table below gives the atomic numbers of elements W, X, Y and Z.
The letters do not represent the actual symbols of the elements.

Element	W	X	Y	Z
Atomic number	9	10	11	12

- a) Which one of the elements is least reactive? (1 mark)
- b) i) Which two elements would react most vigorously with each other? (1 mark)
- ii) Give the formula of the compound formed when elements in b) (i) reacts. (1 mark)
32. When magnesium metal is burnt in air it reacts with both oxygen and nitrogen gases giving a white ash.
- a) Write two equations for the reaction that take place. (2 marks)
- b) When the white ash in (a) above is mixed with water, a gas with a pungent smell is produced. Write an equation for this reaction. (1 mark)
33. In an experiment to separate a mixture of two organic liquids, liquid M (boiling point of 56°C) and liquid N (boiling point of 118°C). A student set up the apparatus as shown below

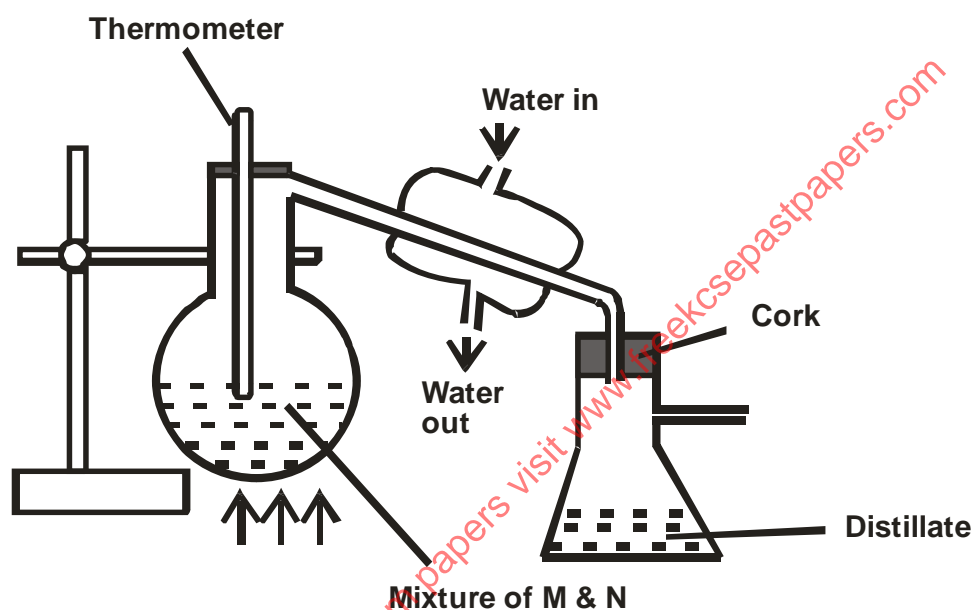

- a) Identify **two** mistakes in the set-up. (2 marks)
- b) What method would the student use to test the purity of the distillates obtained? (1 mark)

CHEMISTRY PAPER 1,2 & 3
MERU CENTRAL CLUSTER EXAMS
 233/2
CHEMISTRY
PAPER 2
(THEORY)

1. The grid bellow represents part of the periodic table. Study it and answer the questions that follow. The letters are not the actual symbols of the elements.

			F		J		H
B		E		L			K
	C		G				
D							

- i. Select the most reactive non-metal. Explain. (2 marks)
 - ii. Identify an element that can form an amphoteric hydroxide. (1 mark)
 - iii. Which group one element has the lowest first ionization energy? Explain. (2 marks)
 - iv. Name the other group to which element A can be placed and give a reason. (2 marks)
 - v. Compare the atomic size of elements C and G. Explain. (2 marks)
 - vi. Write the electronic configuration of the ion formed by element L and indicate its symbol. (1 mark)
- vii. i) Using dots (•) and crosses (x) to represent electrons, show the bonding in the compound formed between elements B and J. (1 mark)
- ii) Identify an element that is not likely to form any type of bond. Explain. (1 mark)
2. a) Study the reaction scheme below and answer the questions that follow.

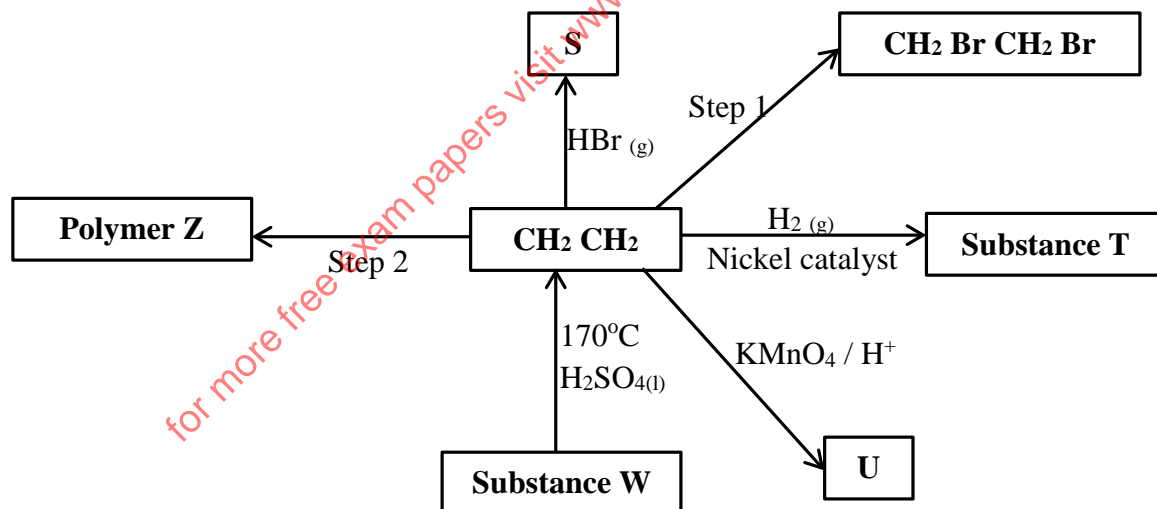

- i) Name the substances; S, T, U and W. (2 marks)
 - ii) Name the reagent for step 1. (1 mark)
 - iii) Draw the polymer Z comprising of three monomers. (1 mark)
 - iv) Name the type of polymerisation on step 2. (1 mark)
- b) Draw the structures of the following compounds.
- i. 2-bromo-3, 3-dimethylpent-1-ene. (1 mark)
 - ii. 1, 2-dichloroethyne. (1 mark)

C) Name the following organic compounds.

i.

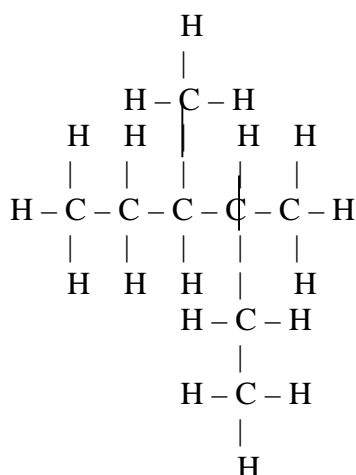

ii. $\text{CH}_3\text{CHCl}(\text{CH}_2)_2\text{C}(\text{CH}_3)_2\text{CH}_2\text{CH}_3$

(1 mark)

d) Draw and name two positional isomers of pentene.

(2 marks)

3. The flow chart below shows how sulphuric (VI) acid is produced on a large scale.

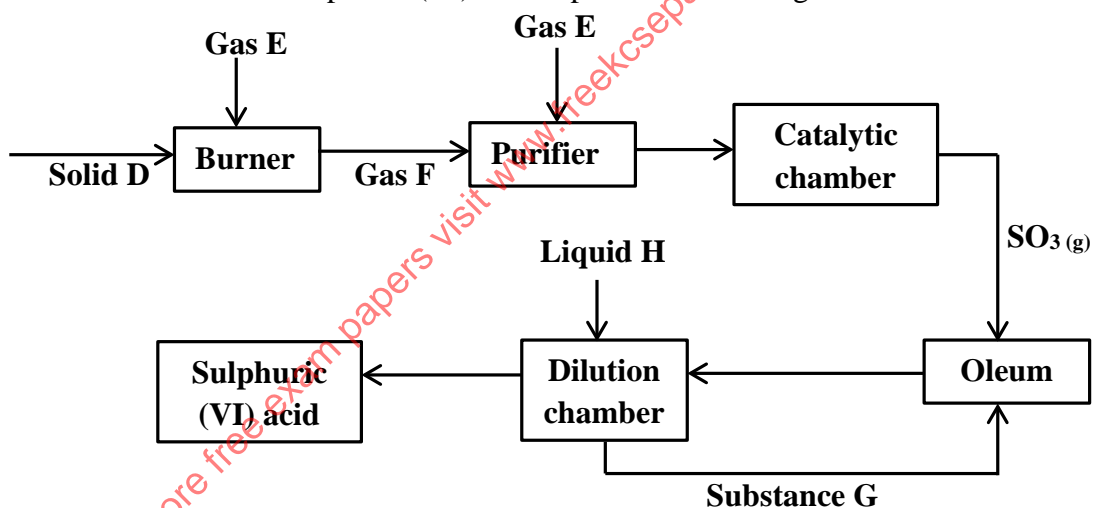

a) Identify the following;

i) Gas E

(½ mark)

ii) Gas F

(½ mark)

iii) Solid D

(½ mark)

iv) Substance G

(½ mark)

v) Liquid H

(½ mark)

b) Name the most preferred catalyst used in the catalytic chamber and give a reason.

(1½ marks)

c) Write an equation for the reaction that forms oleum.

(1 mark)

d) Explain the importance of the purifier.

(2 marks)

e) State **two** ways how pollution is controlled during the process of manufacturing sulphuric (VI) acid.

(2 marks)

f) State **one** industrial application of sulphuric (VI) acid.

(1 mark)

g) What is the name given to the industrial process of manufacturing sulphuric (VI) acid?

(1 mark)

4. The diagram below shows the preparation of Iron (III) chloride salt in the laboratory. Study it and answer the questions that follow.

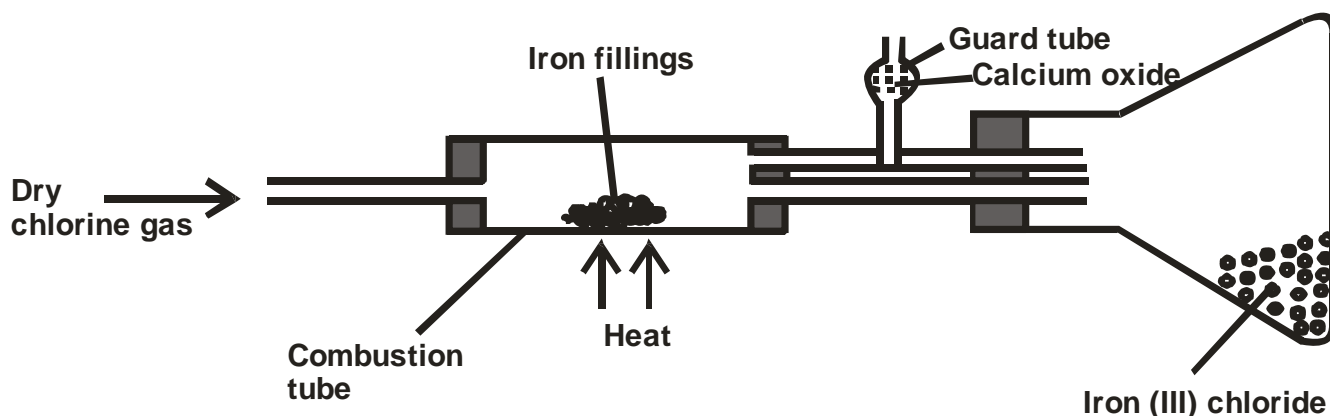

- a) Name the method of preparing Iron (III) chloride salt shown above. (1 mark)
- b) Explain why;
- It is necessary to pass chlorine gas through the apparatus before heating begins. (1 mark)
 - Calcium oxide is more preferred in the guard tube than calcium chloride. (2 marks)
- c) i) What property of Iron (III) chloride makes it possible to be collected as shown in the diagram. (½ mark)
- Name another substance which has the same property as Iron (III) chloride. (½ mark)
- d) Write an equation of the reaction which takes place in the guard tube. (1 mark)
- e) Explain why all dry apparatus and conditions are preferred in the experiment above. (1 mark)
- f) The total mass of Iron (III) chloride formed was found to be 0.5g. Calculate the volume of chlorine gas that reacted with Iron. (Fe = 56, Cl = 35.5, Molar gas volume = 24000cm³) (3 marks)
- g) When hydrogen sulphide gas was passed through a solution of Iron (III) chloride, the following observation were made; red-brown solution changed to green and a yellow solid deposited. Explain this observation. (2 marks)
5. a) State the Hess's law. (1 mark)
- b) Study the equations below and answer the questions that follow.
- $C_{(s)} + O_{2(g)} \longrightarrow CO_{2(g)}$ $\Delta H_1 = -393 \text{ kJmol}^{-1}$
 - $H_{2(g)} + \frac{1}{2}O_{2(g)} \longrightarrow H_2O_{(l)}$ $\Delta H_2 = -286 \text{ kJmol}^{-1}$
 - $C_3H_{8(g)} + 5O_{2(g)} \longrightarrow 3CO_{2(g)} + 4H_2O_{(l)}$ $\Delta H_3 = -2209 \text{ kJmol}^{-1}$
- Name **two** heat changes represented by ΔH_1 (2 marks)
 - Calculate the heat of formation of propane from the equations above, using the energy cycle diagram. (3 marks)
 - Draw the energy level diagram for equation III. (2 marks)
6. a) Candle wax is a compound comprising of two elements. Name them. (2 marks)
- b) The set-up below was used to investigate the burning of a candle. Study it and answer the questions that follow.

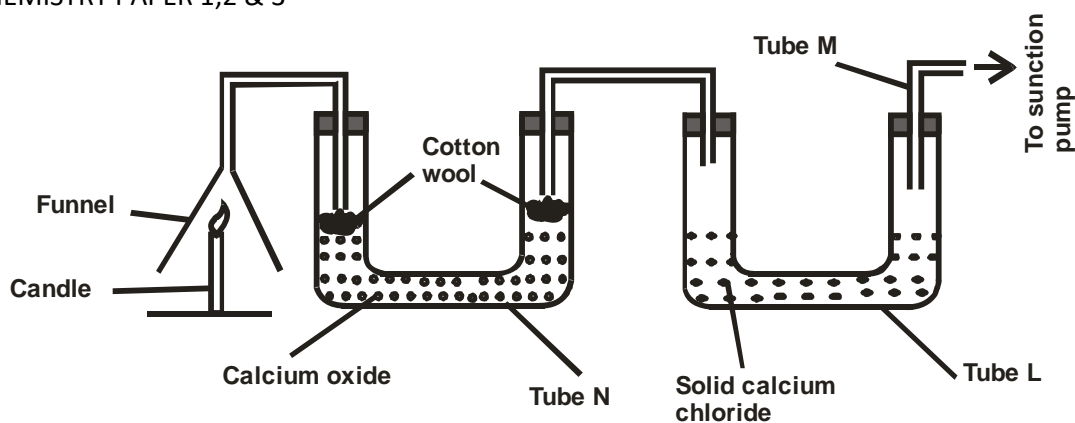

- i. What would happen to the burning candle if the suction pump was turned off. Explain. (2 marks)
 - ii. Explain the purpose of calcium oxide in tube N? (2 marks)
 - iii. What is the role solid calcium chloride in tube L.? (1 mark)
 - iv. Name another substance that could be used in place of calcium oxide in tube N. (1 mark)
 - v. State **two** gases that came out through tube M. (2 marks)
7. A colourless gas was passed over heated lead (II) oxide and the products of the reactions were collected as shown in the diagram below.

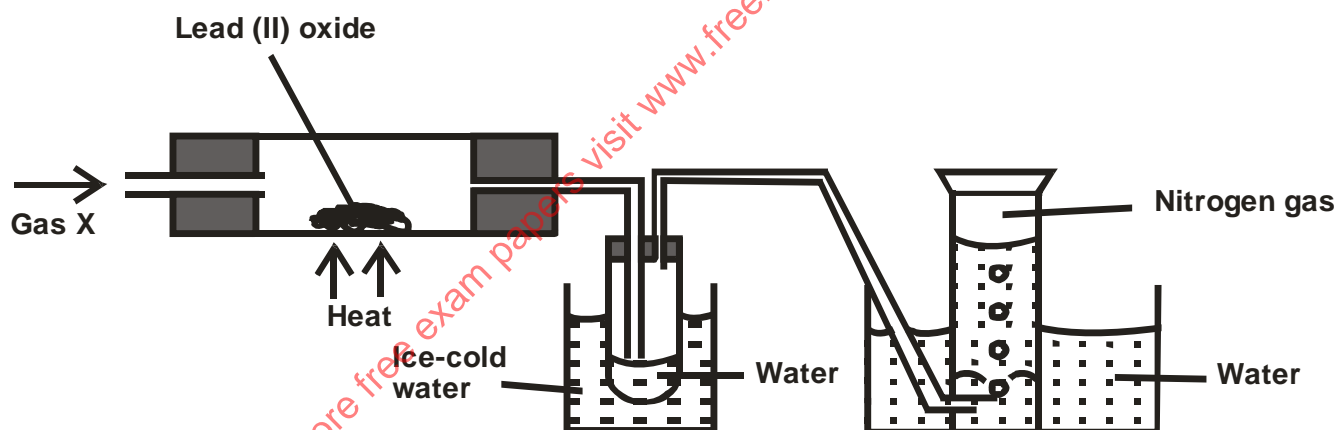

- a) Name gas X. (1 mark)
 - b) State the observation made in the combustion tube. (1 mark)
 - c) What is the purpose of the ice-cold water? (1 mark)
 - d) Write an equation for the reaction that takes place in the combustion tube. (1 mark)
 - e) Why is it possible to collect nitrogen gas as shown in the set up? (1 mark)
 - f) Name the method of obtaining nitrogen gas from air. (1 mark)
8. In an experiment to determine the rate of reaction excess lumps of calcium carbonate were added to 2M hydrochloric acid. The mass of calcium carbonate left was recorded after every 30 seconds. The results are shown in the table below.

Time (seconds)	0	39	60	90	120	150	180	210
Mass of calcium carbonate left	2.00	1.60	1.30	1.00	0.85	0.80	0.80	0.80

(g)

CHEMISTRY PAPER 1,2 & 3

- a) Write the equation for the reaction that took place. (1 mark)
- b) On the graph paper provided, plot a graph of mass of calcium carbonate (vertical axis) against time. (3 marks)
- c) From the graph;
- Determine the rate of reaction at the 105th second. (2 marks)
 - Why does the curve level off after some time? (1 mark)
- d) On the same graph sketch a curve for the same reaction using 4M hydrochloric acid and level it. (1 mark)
- e) Explain why the experiment above would not be performed with dilute sulphuric (VI) acid. (2 marks)

for more free exam papers visit www.freekcsepastpapers.com

CHEMISTRY PAPER 1,2 & 3

Final burette reading (cm³)

Initial burette reading (cm³)

Volume of solution A used (cm³)

- (4 marks)
- a) Determine the average volume of solution A used. (1 mark)
- b) How many moles of sodium carbonate were used? (1 mark)
- c) If 1 mole of A reacts with 1 mole of Na₂CO₃, how many moles of A were used? (1 mark)
- d) Determine the molarity of solution A. (1 mark)
- e) Determine the molar mass of solid A. (1 mark)
- f) If the formula of A is (COOH)₂.XH₂O. Determine the value of X. (C = 12, O = 16, H = 1) (2 marks)

2. You are provided with solid C. Use it to carry the tests outlined below.

Dissolve the whole of C into 10cm³ of distilled water and divide the resulting solution in to 5 portions.

a) To the first portion add dilute hydrochloric acid.

Observations	Inferences
(1 mark)	(2 marks)

b) To the second portion add sodium hydroxide dropwise until in excess.

Observations	Inferences
(1 mark)	(1 mark)

c) To the third portion add sodium sulphate solution.

Observations	Inferences
(1 mark)	(1 mark)

d) To the fourth portion add Lead (II) nitrate solution.

Observations	Inferences
(1 mark)	(1 mark)

e) To the last portion add Barium Nitrate solution.

Observations	Inferences
(1 mark)	(1 mark)

3. You are provided with solid D. Use it to carry the tests outlined below.

a) Ignite $\frac{1}{3}$ of solid D in a metallic spatula using a non-luminous flame.

Observations	Inferences
(1 mark)	(1 mark)

b) To the remaining solid D in the test tube, add 6cm³ of distilled water and divide the resulting mixture into 3 portions.

i) To the first portion add solid sodium hydrogen carbonate.

Observations	Inferences
(1 mark)	(1 mark)

ii) To the second portion add acidified KMnO_4 (potassium manganate (VII)).

Observations (1 mark)	Inferences (1 mark)
--------------------------	-------------------------

iii) To the last portion add bromine water.

Observations (1 mark)	Inferences (1 mark)
--------------------------	-------------------------

ii) - Showing on the graph ----- award ½ mk

- Showing and reading should be form a current graph otherwise award a zero

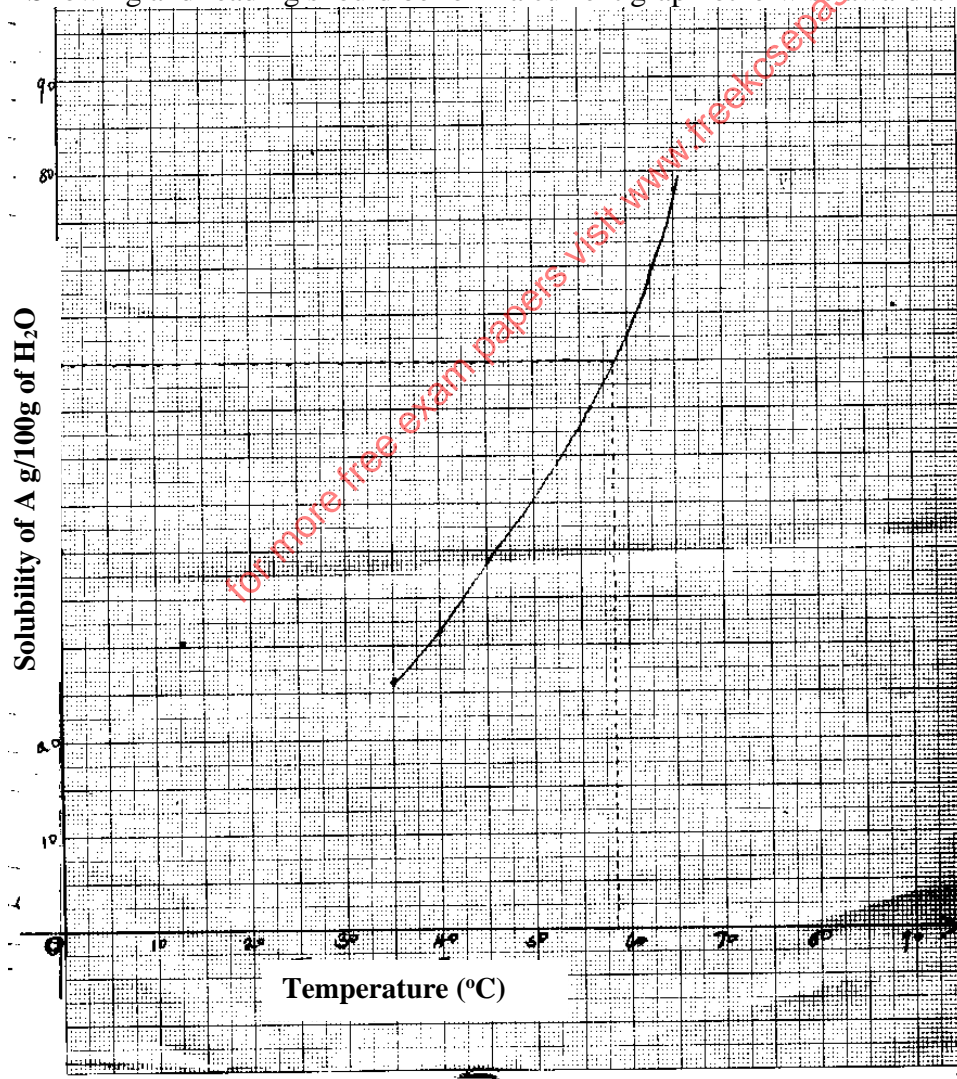

Procedure 2
Table 2

CHEMISTRY PAPER 1,2 & 3

- Award a total of 5mks distributed as follows

a) Complete table 1mk

- Complete 3 titrations done 1 mark
- Incomplete table with 2 titrations done $\frac{1}{2}$ mk
- Incomplete table with 1 titration done 0 mk

Penalties

- Penalize $\frac{1}{2}$ mk for each if the following errors to a maximum of $\frac{1}{2}$ mks (subtract $\frac{1}{2}$ mk once)
- Wrong arithmetic

- Inverted table

- Burette reading above 50cm^3 without explanation

- Unrealistic titre values (above 100cm^3 and below 1cm^3)

b) Decimals -----1mk

- Accept either 1 or 2 d.p consistency used

- If d.p are used the 2nd d.p must be a zero or 5 (o 0r 5) otherwise penalize fully

- Accept inconsistently of zeros as initial burette reading

c) Accuracy -----1mk

- Compare the candidate titre value with the S.V

- Tick the chosen value where it earn a mark

- If at least one value is within $\pm 0.1\text{cm}^3$ of S.V ----- 1mk

- If at least one value is within $\pm 0.2\text{cm}^3$ of S.V ----- $\frac{1}{2}$ mk

- If at least no value is within $\pm 0.\text{cm}^3$ of S.V ----- 0mk

for more free exam papers visit www.freekcsepastpapers.com

CHEMISTRY PAPER 1,2 & 3

d) Principle averaging -----1mk

Conditions

- If the consistence values are averaged ---1mk
- If the 3 titrations are done but 2 are consistence and averaged ---1mk
- If the 2 titrations are done but 1 are consistence and averaged ---1mk
- If the 3 possible titrations are done but 2 are consistence and averaged --- 0mk
- If the 3 titrations are done and are inconsistency and averaged ---0mk

Penalties

- Penalize ½ mk for wrong arithmetic
- Penalize ½ mk if no working shown
- If working is shown and answer given is wrong penalize fully
- Accept rounding off to 2 d.p

e) Final accuracy

- Compare the candidate's correct average titre with the S.V
- If within ± 0.1 award 1mk
- If within ± 0.2 award ½ mk

NB: If wrong values are averaged, pick the correct values if (any) and do the calculation for the candidate and award accordingly

TABLE 2

	I	II	III
Final burette reading	25.0	25.0	25.0
Initial burette reading	0.0	0.0	0.0
Volume of solution A used	25.0	25.0	25.0

a) $\frac{25.0+25.0+25.0}{3} \checkmark^{1/2} = 25.0 \checkmark^{1/2}$

b) $1000\text{cm}^3 \rightarrow 0.1$
 $25\text{cm}^3 \rightarrow ?$

$\frac{25 \times 0.1}{1000} \checkmark^{1/2} = 0.0025 \checkmark^{1/2}$

c) $0.0025 \times 1 \checkmark^{1/2}$
 $= 0.0025 \checkmark^{1/2}$ Accept Ans only for full mks

d) $0.0025 \rightarrow 25$
 $? \leftarrow 1000$

$\frac{1000 \times 0.0025}{25} \checkmark^{1/2}$
 $= 0.1\text{M} \checkmark^{1/2}$

e) $3.15 \times 4 = 0.1$
 $? = 1$

$\frac{12.6 \times 1}{0.1} \checkmark^{1/2}$
 $= 126 \checkmark^{1/2}$

f) $(\text{COOH})_2 \cdot \text{XH}_2\text{O} = 126$

$(12 + 16 + 16 + 1)_2 + 18 = 126 \checkmark^{1/2}$

$90 + 18x = 126 \checkmark^{1/2}$

$18x = 36 \checkmark^{1/2}$

$X = 2 \checkmark^{1/2}$

CHEMISTRY PAPER 1,2 & 3

2. a)

Observation
No effervescence ✓^{1/2}
No white precipitate ✓^{1/2}

Inferences
SO₃²⁻ ✓^{1/2} and CO₃²⁻ ✓^{1/2} Absent
Pb²⁺ ✓^{1/2} and Ag⁺ ✓^{1/2} absent
NB: penalise ½ mk to a maximum of 2 mks for any contradicting ion
Accept the names of the ions e.g. Lead ions

b)

Observation
White precipitate ✓^{1/2} Insoluble in excess ✓^{1/2}

Inferences
Al³⁺ ✓^{1/2} and Zn²⁺ ✓^{1/2} Absent
Accept
Mg²⁺ and Ba²⁺ or Ca²⁺ present
For full maximum for any two
NB: penalise ½ mk for any contradicting ion to a maximum of 1 mk
Accept the names of the ions

c)

Observation
No white precipitate ✓1

Inferences
Mg²⁺ present ✓1
Accept
Ba²⁺ or Ca²⁺ Absent
For ½ mk each
NB: penalise ½ mk for any contradicting ion to a maximum of 1 mk
Accept the names of the ions

d)

Observation
White precipitate is formed ✓1

Inferences
Cl⁻ or SO₄²⁻ present ✓1
Accept chloride or sulphate in names
NB: penalise ½ mk to a maximum of 1 mk for any contradicting ion

e)

Observation
White precipitate formed ✓1

Inferences
SO₄²⁻ present ✓1
Accept Cl⁻ absent for ½ mk
Accept name of ions
NB: penalise ½ mk for any contradicting ion to a maximum of 1 mk

3. a)

observation
Solid D bums with a yellow flame

Inferences
\ /
C = C - C ≡ C - present
/ \

Accept sooty or smoky for full marks

Accept unsaturated compound present
Penalize 1mk for any contradicting functional group
Reject Alkenes or Alkynes

CHEMISTRY PAPER 1,2 & 3
(1 mark)

b) i)

Observations
No effervescence
Accept No bubbling

Inferences
R – COOH Absent
Accept
H⁺ H₃O⁺ Absent for 1mk each

ii)

Observations

Acidified KMnO₄ get decolourised

Inferences

\ /

Accept KMnO₄ turns from purple to colourless

/ C = C \ or - C ≡ C - present

Or

R – OH

iii)

Observations

Bromine water get decolourised

Inferences

\ /

Accept

Orange bromine water turns colourless

/ C = C \ or - C ≡ C - present

Accept red colour of bromine

Reject any other colour

Accept

R – OH absent for ½ mk

for more free exam papers visit www.freekscsepastpapers.com

CHEMISTRY PAPER 1,2 & 3
LANGATA/DAGORETTI C LUSTER
233/1
CHEMISTRY
(THEORY)
PAPER 1

1. A Student in form four placed a thermometer in molten naphthalene at 85°C and recorded the temperature and time until the naphthalene solidified. From the values obtained, the figure below was drawn.

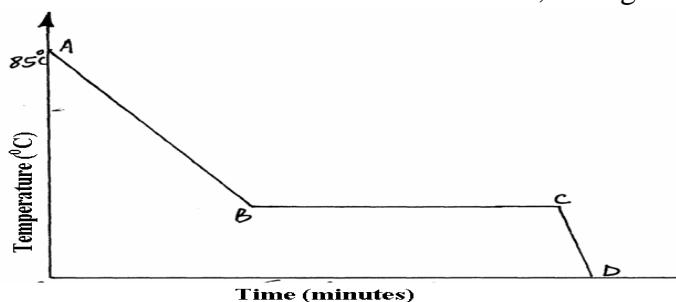

- (a) What name is given to such a figure?.....
 (1mk)
- (b) Which part of the figure represents the change of state of naphthalene?.....
 (1mk)
- (c) In terms of kinetic theory. Explain what happens to molecules along AB. (1mk)
2. In a certain reaction, 18.7cm³ of a dibasic acid H_2X required 25cm³ of 0.1M NaOH for complete neutralization.
- (a) How many moles of Sodium hydroxide are contained in 25cm³?
 (1mk)
- (b) Calculate the molarity of the dibasic acid. (2mks)

3. Study the flow chart below and answer the questions that follow.

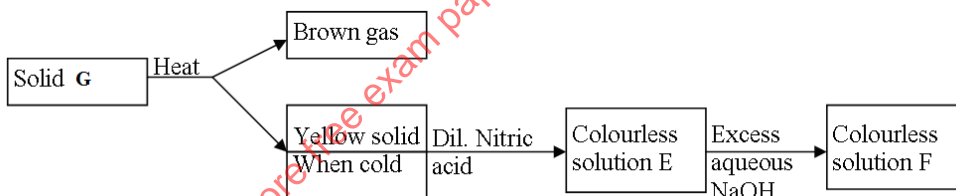

- (a) Identify solid G (1mk)
- (b) Write a balanced chemical equation between the yellow solid and dilute nitric acid. (1mk)
- (c) Write the formula of the complex ion in solution F (1mk)
4. Explain this observation:
 When hydrogen chloride gas is dissolved in water, the solution conducts electricity while a solution of hydrogen chloride gas in methyl benzene does not conduct electricity.
 (2mks)
5. Matter exists in three states which can be related as shown in the diagram below.

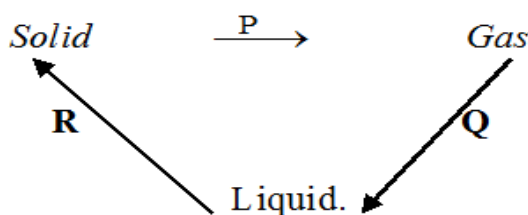

- (a) Name processes: P: (1mark)
 R: (1mark)
- (b) Explain whether process Q is exothermic or endothermic (1mark)
6. (a) What is meant by allotropy? (1mark)
 (b) Name two allotropes of carbon. (1mark)
 (c) Give one use of charcoal in the sugar refinery industry. (1mk)
7. (a) State Graham's Law of Diffusion (1mk)
 (b) A given volume of ozone (O₃) diffused from a certain apparatus in 96 seconds. Calculate the time taken by an equal volume of carbon(IV) oxide to diffuse under the same conditions. (C=12,O=16) (2mks)
8. (a) Name two ores from which copper is extracted. (1mk)
 (b) During the extraction of copper metal the ore is subjected to froth floatation. Give a reason why this process is necessary. (1mk)
 (c) One of the alloys of copper is brass. State its two uses. (1mk)
9. Draw a dot (●) and cross (X) diagram to show bonding in sulphur (IV) oxide (1mk)
10. A form one class carried out an experiment to determine the active part of air. The diagram below shows the set-up of the experiment and also the observation made.

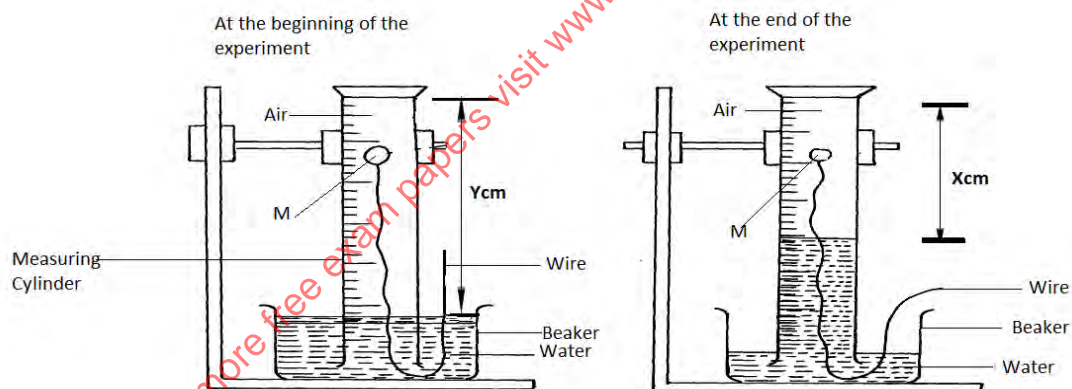

- (a) Identify substance M (1mk)
 (b) State two reasons for the suitability of substance M for this experiment (1mk)
 (c) Write the equation for the reaction of substance M and the active part of air (1mk)
11. (a) Complete the following equation (1mk)
- $$\begin{array}{c} \text{H} & & \text{H} \\ & \diagdown & / \\ & \text{C} = \text{C} & \\ & / & \diagdown \\ \text{H} & & \text{H} \end{array} + \xrightarrow[\text{H}^+]{\text{KMnO}_4}$$
- (b) Name the homologous series to which the following compounds belong?
 (i) CH₃CCH (1mk)
 (ii) CH₃CH₂OOCCH₃ (1mk)

12. The table below shows the pH values of solutions J to N

Solution	J	K	L	M	N
pH	5	13	2	10	7

- (a) Which solution contains the largest concentration of hydroxide ions? (1mk)
- (b) Which solution is likely to be a solution of acetic acid? (1mk)

for more free exam papers visit www.freekcsepastpapers.com

13. The scheme below was used to prepare a cleansing agent. Study it and answer the questions that follow.

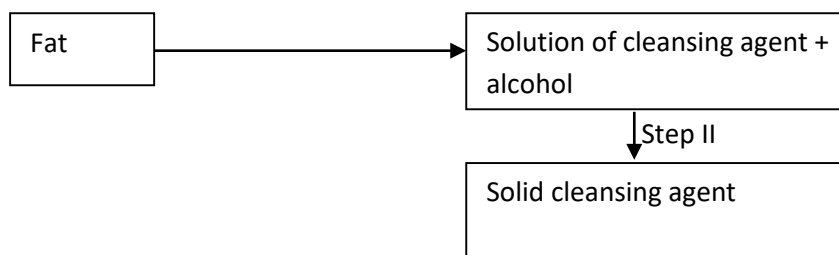

- (i) What name is given to the type of cleansing agent prepared by the method shown in the scheme?
(1mk)
- (ii) Name one chemical substance added in step II (1mk)
- (iii) What is the purpose of adding the chemical substance named in (ii) above. (1mk)
14. a) Define half – life of radio isotopes. (1mk)
- b) Z grammes of a radioactive isotope take 100 days to decay to 20gms. If the half – life of the element is 25 days. **Calculate** the initial mass of Z of the radio- isotope. (2mks)
15. Magnesium was burnt in air forming a white residue T. When put in a boiling tube with water effervescence was noticed and colourless gas D with a characteristic pungent smell was evolved. The gas turned a wet red litmus paper blue.
- (a) **Identify**
- (i) Residue T (1mk)
- (ii) Gas D..... (1mk)
- (b) **Write** an equation for liberation of gas D. (1mk)
16. Explain why the bleaching action of chlorine is permanent while bleaching by sulphur (IV) oxide is temporary. (2marks)
17. Explain how you would separate a mixture of nitrogen and oxygen gases given that their boiling points are -196°C and -183°C respectively. (3mks)
18. Hydrazine gas, shown below, burns in oxygen to form nitrogen gas and steam.



- (a) Write an equation for the reaction (1mk)
- (b) Using the bond energies given below, calculate the enthalpy change for the reaction in (a) above

(2mks)

Bond	Bond energy KJ per mole
$\text{N} \equiv \text{N}$	944
$\text{N}=\text{N}$	163
$\text{N}-\text{H}$	388

CHEMISTRY PAPER 1,2 & 3

O =O 496

H-O 463

for more free exam papers visit www.freekcsepastpapers.com

19 Using reagents provided only, explain how you could prepare solid Zinc carbonate.
(2mks)

- Zinc powder
- Nitric (V) acid (dilute)
- Water
- Solid sodium carbonate

20 The apparatus below was set up to show the catalytic oxidation of ammonia.

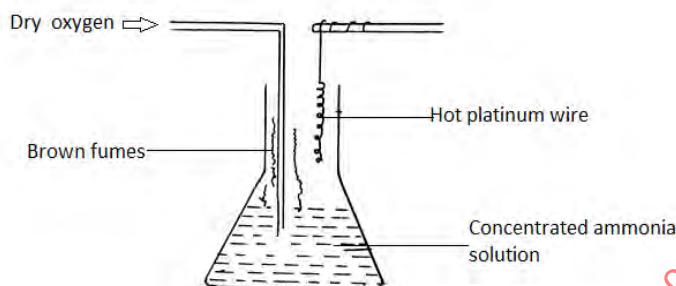

(a) Identify the brown fumes observed at the mouth of the conical flask.

(1mk)

(b) Write down the equations of the reactions representing

(i) Catalytic oxidation of ammonia

(1mk)

(ii) The formation of the brown fumes.

(1mk)

21 Consider the chromatogram below.

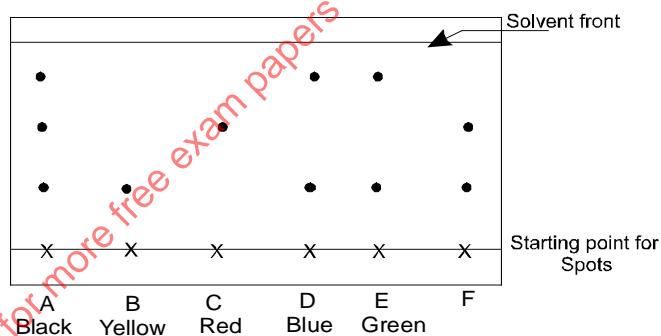

A piece of chromatogram paper was spotted with colour inks obtained from pens labeled A to F. The diagram above shows the spots after the chromatograph was developed.

(a) Which two pens contained the same pigment?

(1mk)

(b) According to the chromatogram which pigments are present in the inks of the pen number F

(1mk)

(c) Describe how one could get a sample of yellow pigment

(1mk)

22. Consider the following reaction at equilibrium.

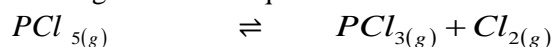

Complete the table below to show the effect of different factors on the position of equilibrium

(3mks)

Factor	Effect on the equilibrium position
(i) Decrease pressure	

(ii) Removing chlorine	
(iii) Adding Helium gas to mixture	

23. A student investigated the effect of an electric current by passing it through some substances. The student used inert electrodes and connected a bulb to the circuit. The table below shows the substances used and their states.

Experiment	Substance	State
1	Potassium carbonate	Solid
2	Copper (II) sulphate	Solution
3	Sugar	Solution
4	Lead (II) iodide	Molten

(a) In which experiments did the bulb not light? (1mk)

(b) Explain your answer in (a) above. (2mks)

24. Give a reason why the formula mass of NO_2 is sometimes 92 instead of 46. (1mk)

25. A compound contains only carbon, hydrogen and oxygen. Combustion of 1.068g of the compound produces 1.601g of carbon (IV) oxide and 0.437g of water. The molar mass of the compound is 176.1g/mol. What is the empirical and molecular formulae of the compound? (2mks)

26. (a) A sample of water in a beaker was found to boil at 102°C at 1 atmospheric pressure. Assume that the thermometer was not faulty explain this observation (1mk)

(b) Study the information in the table below and answer the questions that follow.

Salt	Solubility (g/100g water)	
	At 40°C	At 60°C
CuSO_4	28	38
$\text{Pb}(\text{NO}_3)_2$	79	98

A mixture containing 35g of CuSO_4 and 78g of $\text{Pb}(\text{NO}_3)_2$ in 100g of water at 60°C was cooled to 40°C

(i) Which salt crystallized out? Give a reason. (1mk)

(ii) Calculate the mass of the salt that crystallized out. (1mk)

27. A student was asked to determine the percentage of zinc metal in a mixture of zinc metal and zinc oxide. He reacted the mixture with excess hydrochloric acid and accurately collected the gas evolved, which was then used to calculate the amount of zinc in the mixture.

(a) Name the gas that was evolved..... (1 mark)

(b) Apart from the reaction liberating the gas write a balanced equation for the other reaction that took place. (1 mark)

(c) Why would dilute nitric acid not be suitable for this reaction? (1 mark)

28. Below is part of the flow diagram of the contact process.

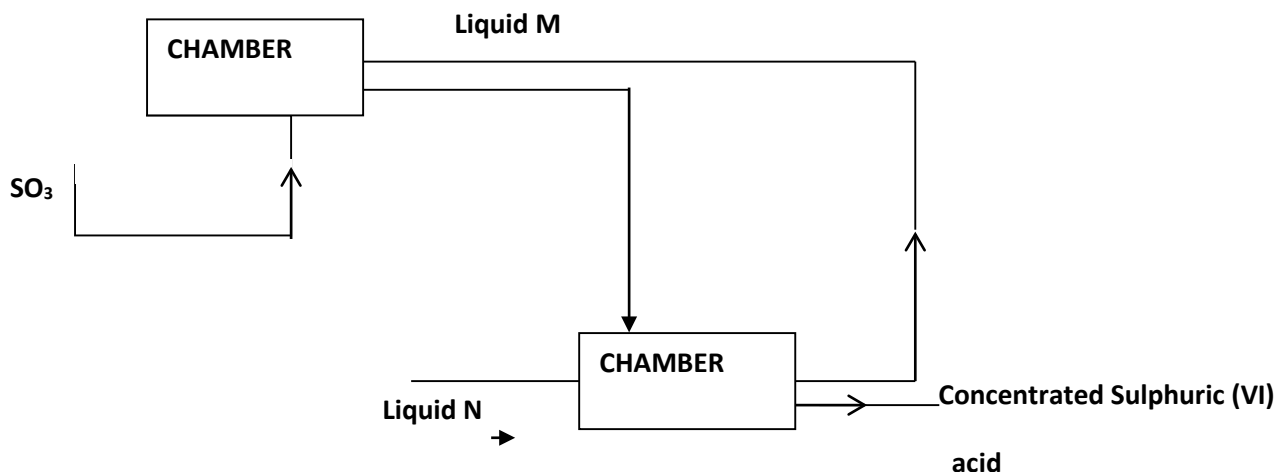

- (a) Identify (i) Liquid M..... (1mk)
 (ii) Liquid N..... (1mk)
- (b) Write the equation for the reaction taking place in chamber B. (1mk)
29. Chlorine gas dissolved in distilled water to form chlorine water
- (a) Name the compounds present in the chlorine water. (1mk)
- (b) What would be observed if blue litmus paper is dipped in chlorine water? Explain. (2mks)
30. A fixed mass of gas occupies 105cm^3 at -14°C and 650mmHg pressure. At what temperature will it have a volume of 15cm^3 if the pressure is adjusted to 690 mmHg pressure (2mks)

LANGATA/DAGORETTI CLUSTER

233/2

CHEMISTRY

Paper 2

THEORY

1. The grid below represents part of the periodic table. Study it and answer the questions that follow. The letters do not represent the actual symbols of the element.

				N		S		
K	Q		O			P	F	M
	R							

- a) What name is given to the group of elements to which Q and R belong? (1 mark)
- b) Write the formula of the compound formed when Q and P combine. (1 mark)
- c) Name the type of bond formed in (b) above. (1 mark)
- d) How does the atomic radii of O and P compare? Give a reason. (2 marks)
- e) Draw a dot (.) and cross (x) diagram for the compound formed between N and F. (1 mark)
- f) Explain how you would obtain a pure sample of the carbonate of K from its mixture with Lead carbonate powder. (2 marks)
- g) Give one use of element M. (1 mark)

CHEMISTRY PAPER 1,2 & 3

- h) The melting point of M is -189°C lower than that of F -102°C . Explain this difference in their melting points. (2 marks)

2. The list below shows the formulae of some organic compounds. Use letters T1 to T6 to answer the questions that follow.



- (a) Select two compounds which:

(i) Are not hydrocarbons (1mk)

(ii) Would decolourise both bromine water and acidified potassium manganate (VII) (1mk)

(iii) Would produce hydrogen gas when reacted with potassium metal (1mk)

- (b) Select a compound which would produce bubbles of a gas when reacted with sodium carbonate. (1mk)

- (c) (i) Identify the compound that is likely to undergo polymerization. Give a reason for your answer. Using two molecules show how polymerization occurs.

I. Compound (1mk)

II. Reasons (1mk)

III. Polymerization (1mk)

- (iv) Name the process by which compound T₂ is formed and identify the compounds that were used to form it.

I. Process (1mk)

II. Compounds (1mk)

- (d) Compound T₃ can be converted to T₄ as shown by the equation below:

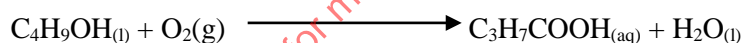

Given the following information:

$$\Delta H_c \text{ for } \text{C}_4\text{H}_9\text{OH} = -4910 \text{ kJ/mol}$$

$$\Delta H_c \text{ for } \text{C}_3\text{H}_7\text{COOH} = -4090 \text{ kJ/mol}$$

Determine the heat change for the reaction above. (2mks)

3. a) What is meant by the term molar enthalpy of combustion? (1mks)

- b) The enthalpies of combustion of carbon, hydrogen and ethanol are given below.



CHEMISTRY PAPER 1,2 & 3

- i) Draw an energy cycle diagram that links the enthalpy of formation of ethanol to enthalpies of combustion of Carbon, hydrogen and ethanol. (3 marks)
- ii) Determine the enthalpy of formation of ethanol (1 marks)
- c. An experiment was carried out where different volumes of dilute nitric acid (v) acid and aqueous potassium hydroxide both at 25°C were mixed and stirred with a thermometer.

The highest temperature reached by each mixture was recorded in the table below.

Volume of nitric (V) acid (cm ³)	4	8	12	16	20	24	28	32	36
Volume of potassium hydroxide cm ³	36	32	28	24	20	16	12	8	4
Highest temperature of mixture	19.8	22.2	24.6	27.0	27.0	25.0	23.0	21.0	19.0

Plot a graph of highest temperature (vertical axis) against volume of nitric acid. (horizontal axis) 3mks

Using your graph, determine the;

- i. highest temperature reached (½ marks)
- ii. The volume of the acid that reacted when the highest temperature is reached. (½ marks)
- iii. The amount of heat liberated during the neutralization process (Specific heat capacity is 4.2jg⁻¹K⁻¹ and the density of solution is 1.0gcm⁻³) (2 marks)
- d) The molar enthalpies of neutralization for dilute hydrochloric acid and dilute nitric (v) acid are -55 KJmol⁻¹. while that of ethanoic acid is -52.2kJ/mol. Explain this observation. (2 mks)

4. Experiment was set as shown below.

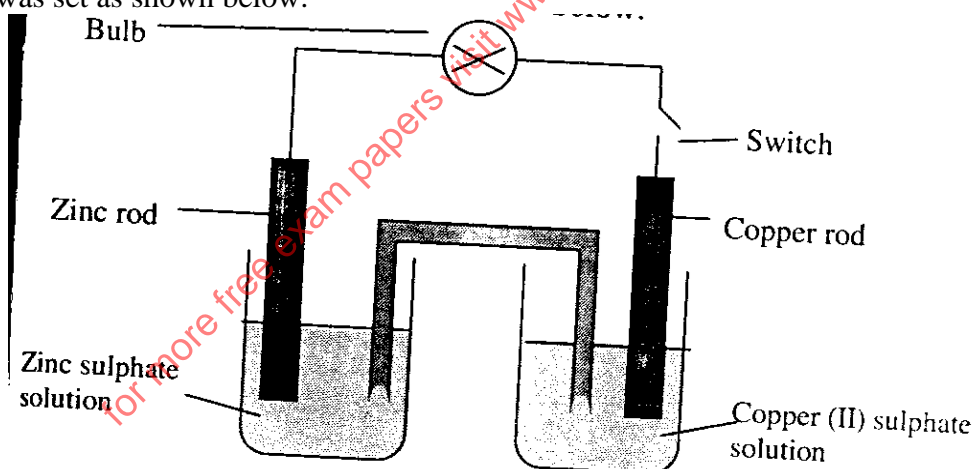

- (a) What is observed on the bulb when the switch is closed? (1mk)
- (b) Which electrode will be cathode? (1mk)
- (c) Write down the half-cell equations for:
- i. Copper electrode. (1mk)
- ii. Zinc electrode. (1mk)
- (d) Write the overall ionic equation for the electrochemical cell. (1mk)
- (e) The table below shows the electrode potentials.





What is the value of the voltage of the cell?

(2mks)

(f) The switch is kept closed. State and explain the observation expected after sometime on the

(i) The zinc rod.

(2mks)

(ii) Copper (II) Sulphate solution.

(2mks)

for more free exam papers visit www.freekcsepastpapers.com

5. The chart below represents the extraction of iron and some of its uses.

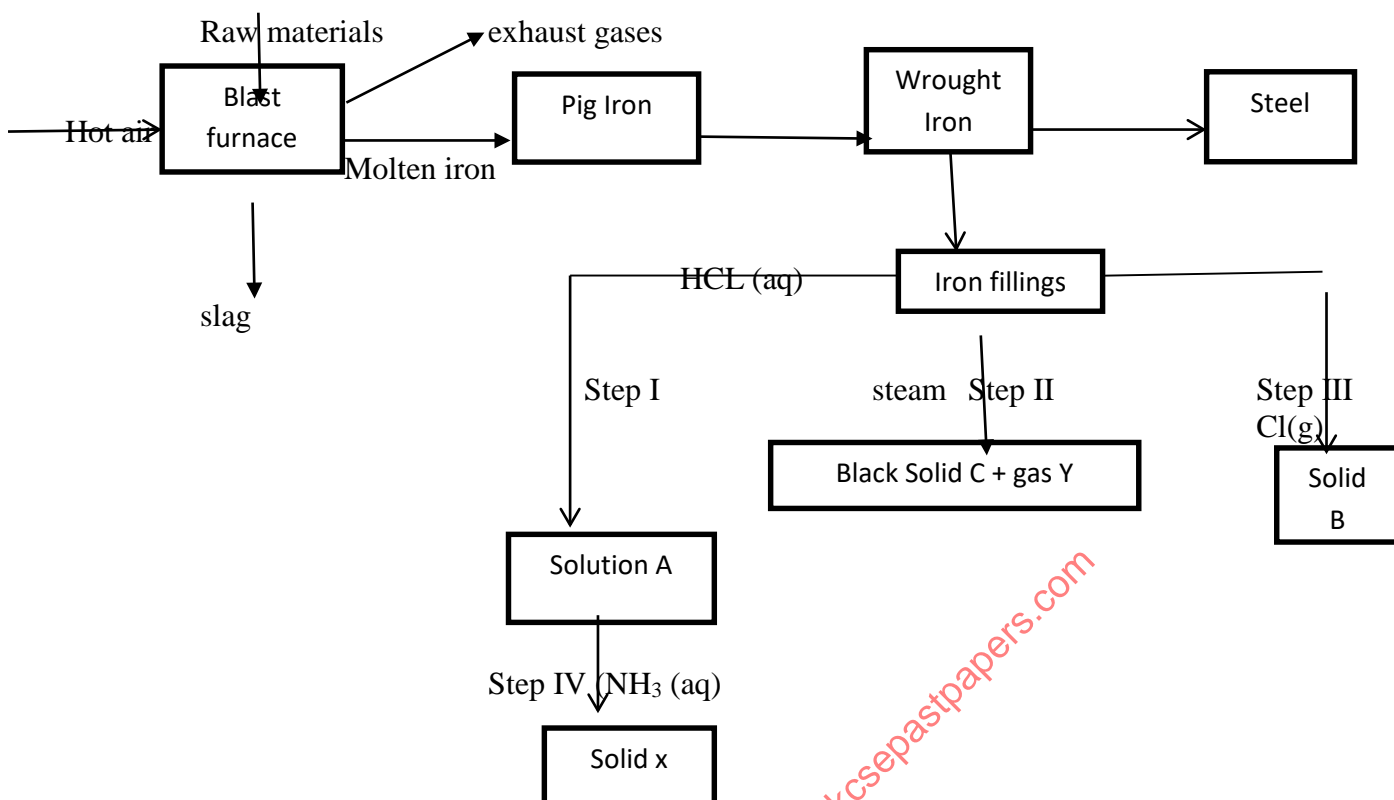

- (a) Name the raw materials fed into the blast furnace. (2mks)
- (b) Name 3 exhaust gases emitted from the blast furnace. (1½mks)
- (c) (i) Why is it necessary to convert pig iron into wrought iron. (1mk)
 (ii) State one commercial use of iron. (1mk)
- (d) Name substances A, B, C, X & Y (2½mks)
- (e) Write equations for reactions in steps
- II (2mks)
 - III (1mk)
 - Write an ionic equation for the reaction in step I. (2mks)
 - What observations are made in steps?
 I
 I

6. Study the flow chart below and answer the questions that follow.

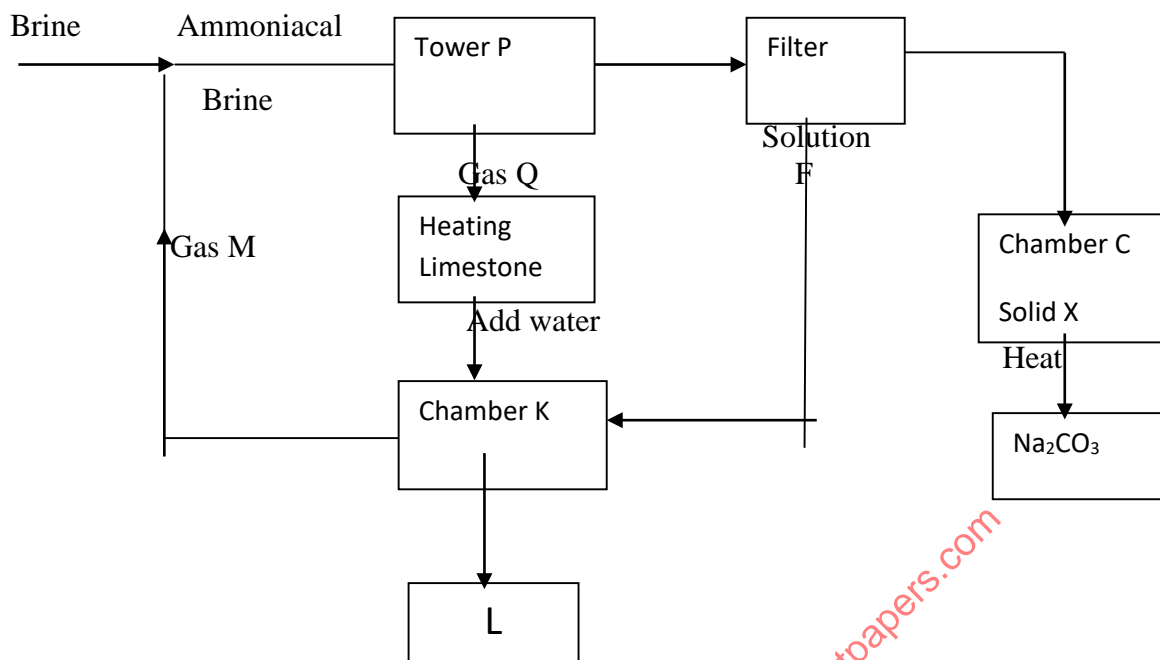

- Name Gas M (1 mark)
 - Name solution F and solid X (1 mark)
 - Name the product L formed and give one of its uses (2 mark)
 - Write equation of the reaction in the;
 - tower P -
 - chamber K -
 - Name two raw materials required in the manufacture of Sodium carbonate (2 marks)
 - Write an equation of the reaction when solid x is heated. (1 mark)
7. The table below shows the volume of nitrogen (IV) Oxide produced when different volumes of 1M Nitric (V) acid – were each reacted with 4.14g of lead at room temperature.

Volume of 1 M Nitric (V) acid (cm ³)	Volume of Nitrogen (IV) oxide gas (cm ³)
10	120
30	360
50	600
70	840
90	960
110	960

- Explain how the rate of the reaction between lead and nitric (V) acid would be affected if the temperature of the reaction mixture was lowered. (1mks)
- On the grid provided below plot a graph of the volume of the gas produced (vertical axis) against volume of acid. (3mks)
- Using the graph, determine the volume of
 - Nitrogen (IV) oxide produced when 60cm³ of 1M Nitric (V) acid were reacted with 4.14g of lead. (1mk)
 - 1M Nitric (V) acid which would react completely with 4.14g of lead. (1mk)
- Using the answer in d(ii)above, determine
 - The volume of 1M Nitric (V) acid that would react completely with one mole of lead. (Pb = 207). (2mks)

CHEMISTRY PAPER 1,2 & 3

- (e) Calculate the number of moles of
- (i) 1M Nitric (IV) acid reacted with one mole of lead. (1mk)
 - (ii) Nitrogen (IV) oxide produced when one mole of lead were reacted with excess nitric acid. (Molar gas volume is 24000cm^3).
- (f) Using the answers obtained in e(i) and e(ii) above; write the equation for the reaction between lead and nitric (V) acid given that one mole of lead (II) nitrate and two moles of water were produced (1mk)
- (g) Give a reason why nitric (V) acid is stored in dark bottles. (1mk)

LANGATA/DAGORETTI CLUSTER

233/3 CHEMISTRY

PAPER 3

END OF TERM II 2020

(CONFIDENTIAL)

In addition to the apparatus found in the laboratory each candidate will require the following

- About 0.5g of solid F
- About 1g of solid G
- 6 clean test-tubes
- Universal indicator solution and a pH chart
- Ethanol supplied with a dropper
- Clean dry metallic spatula
- 1 boiling tube
- Distilled water
- Solution J, about 130cm^3
- Solution Q, about 160cm^3
- Solution R, about 30cm^3
- Screened methyl orange indicator
- Methyl orange indicator
- 100ml measuring cylinder
- Filter paper
- Means of labeling
- Solid P
- Thermometer
- 100ml beaker

Access to the following;

- ❖ Ethanol supplied with a dropper
- ❖ Concentrated sulphuric (VI) acid supplied with a dropper bottle
- ❖ Acidified Potassium dichromate (VI) solution
- ❖ Acidified Potassium Manganate (VII) solution.
- ❖ 2M $\text{Ba}(\text{NO}_3)_2$ solution.
- ❖ 2M NaOH solution.
- ❖ 2M HCl acid.
- ❖ Source of heat.

Preparation

- ✓ Solution J is 0.12M HCL, prepared by adding about 800cm^3 of distilled water to 4.05cm^3 of concentrated HCL of density 1.08gcm^{-3} and making it to one litre of solution.
- ✓ Solution Q is prepared by dissolving 5.3g of anhydrous sodium carbonate in enough distilled water and making up to one litre of solution.

CHEMISTRY PAPER 1,2 & 3

- ✓ Solution R is prepared by dissolving 15.75g of hydrated barium hydroxide in enough distilled water and top up to one litre of solution.
- ✓ Solid P is 2.0g of oxalic acid weighed accurately and supplied in a stoppered container
- ✓ Solid F is maleic acid
- ✓ Solid G is sodium sulphite

233/3

CHEMISTRY

Paper 3

(PRACTICAL)

1. You are provided with:

- A monobasic acid HA, solution J.
- Sodium carbonate solution, solution Q, containing 1.325g in 250cm³ of solution.
- Solution R, containing 15.75g of M(OH).8H₂O per litre.
- Screened methyl orange indicator.

You are required to:

- Standardize solution J.
- Determine the relative atomic mass of element M in M(OH)₂.8H₂O.

Procedure 1

Fill the burette with solution J. Pipette 25cm³ of solution Q into a clean 250ml conical flask and add 2 – 3 drops of screened methyl orange indicator. Titrate this solution with the solution in the burette and record your results in table 1 below. Repeat this procedure and complete the table. **Retain solution J in the burette for use in procedure II.**

Table 1

Titre	I	II	III
Final burette reading (cm ³)			
Initial burette reading(cm ³)			
Volume of J used (cm ³)			

(4 marks)

- a) Calculate the average volume of solution J used. (1 mark)
- b) Determine the concentration of solution Q in moles per litre (Na=23, C=12, O=16) (1 mark)
- c) (i) Determine the number of moles of the monobasic acid solution, HA, that are in the averaged value calculated in (b) above. (1 mark)
- (ii) Determine the concentration of solution J in moles per litre. (1 mark)

Procedure 2

- Using a 25cm³ measuring cylinder, transfer 25cm³ of solution R into a clean 250ml conical flask. Using a 100ml measuring cylinder, transfer 75cm³ of solution Q into the flask with solution R. Boil the mixture for about 5 minutes. After cooling filter into a conical flask and transfer the filtrate into a clean 100ml measuring cylinder and add distilled water to make exactly 100cm³ of solution. Label this solution as solution S.
- Pipette 25cm³ of solution S into a conical flask and titrate it with solution J using 2 drops of screened methyl orange indicator. Record your results in table 2 below. Repeat this to complete the table.

for more free exam papers visit www.freekcsepastpapers.com

Table 2

Titre	I	II	III
Final burette reading (cm ³)			
Initial burette reading (cm ³)			
Volume of J used (cm ³)			

- d) Calculate the average volume of solution J used. (4 marks)
- e) Determine the number of moles of: (1 mark)
- The monobasic acid, HA, in the average volume. (1 mark)
 - Sodium carbonate in 25cm³ of solution S. (1 mark)
 - Sodium carbonate in 75cm³ of solution S. (1 mark)
 - Sodium carbonate in the original 75cm³ of solution S. (1 mark)
 - Sodium carbonate that reacted with solution R. (1 mark)
 - M(OH)₂.8H₂O in 25cm³ of solution R. (1 mark)
- (1 mole of M(OH)₂.8H₂O reacts with one mole of sodium carbonate)
- f) Determine
- the concentration of solution R in moles per litre. (1 mark)
 - the relative formula mass of M(OH)₂.8H₂O. (1 mark)
 - the relative atomic mass of M (O=16.0, H=1.0) (1 mark)

2. You are provided with:
Solid P, 2.0 g of a dibasic acid H₂X.
You are required to determine the molar heat of solution of solid P.

PROCEDURE

Place 30cm³ of distilled water into a 100ml beaker. Measure the initial temperature of the water and record it in the table below. Add all the solid P at once and stir the mixture carefully with the thermometer until all the solid dissolves. Measure the final temperature reached and record it in table.

Final temperature (°C)

Initial temperature (°C)

- Determine the change in temperature, ΔT. (3 marks)
 - Calculate the: (1 mark)
 - heat change when H₂X dissolves in water. (Assume the heat capacity of the solution is 4.2 Jg⁻¹°C⁻¹ and density is 1g/cm³) (2 marks)
 - Number of moles of the acid that were used. (Relative formula mass of H₂X is 126) (1 mark)
 - Molar heat of solution, ΔH, of the acid H₂X. (1 mark)
3. You are provided with solid G. Place all solid G in a boiling tube. Add distilled water and shake. Divide the resulting solution into three portions.

Inferences

(½ mk)

Observations

(½ mk)

CHEMISTRY PAPER 1,2 & 3

- i) To the first portion add drops of 2M sodium hydroxide.

Inferences	Observations
(½ mk)	(½ mk)

- ii) To the second portion dip a metallic spatula in the solution and burn it directly on a non-luminous flame.

Inferences	Observations
(½ mk)	(½ mk)

- iii) To the third portion add three drops of barium nitrate solution followed by 2cm³ of 2M hydrochloric acid.

Inferences	Observations
(½ mk)	(½ mk)

- iv) To the fourth portion add three drops of acidified potassium dichromate (VI) solution.

Inferences	Observations
(½ mk)	(½ mk)

- b) You are provided with solid **F**. Carry out the tests below and record your observations and inferences in the spaces provided

- (i) Using a metallic spatula, heat half of solid **F** in a non-luminous bunsen burner flame .

Inferences	Observations
(½ mk)	(½ mk)

- (ii) Put a half spatula endful of solid **F** into a boiling tube. Add about 10cm³ of distilled water and shake.

Inferences	Observations
(½ mk)	(½ mk)

Divide the resulting solution from a(ii) above into two portions

- (iii) To the first portion, 2-3 drops of universal indicator and determine its pH.

Inferences	Observations
(½ mk)	(½ mk)

- (iv) To the second portion, add two drop of acidified potassium Manganate (VII) solution and shake.

Inferences	Observations
(½ mk)	(½ mk)

CHEMISTRY PAPER 1,2 & 3

- (c) Put half spatula endful of solid **F** into a boiling tube and add 5 drops of ethanol followed by 2 drops of concentrated sulphuric (VI) acid. warm the mixture.

Inferences

(½ mk)

Observations

(½ mk)

for more free exam papers visit www.freekcepastpapers.com

CHEMISTRY PAPER 1, 2 & 3
MURANGA SOUTH
233/1
CHEMISTRY PAPER 1
FORM 4

- State the structural difference between a thistle funnel and a dropping funnel. (1mk)
- The set up below was used to prepare and collect hydrogen sulphide gas. Study it and answer the questions that follow.

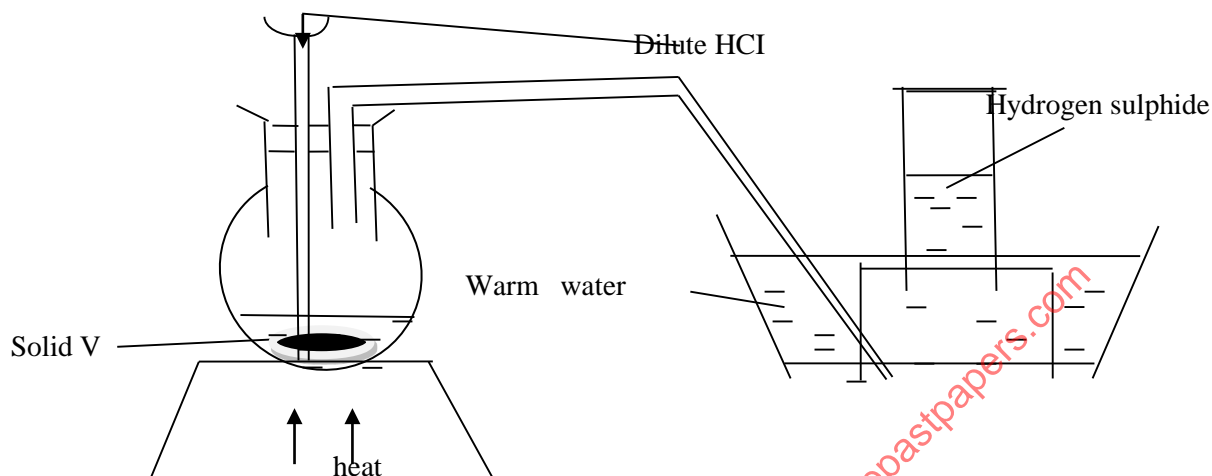

- Name solid V. (1mk)
 - State the observation made in the round bottomed flask containing solid V. (1mk)
 - DESCRIBE the confirmatory test for hydrogen sulphide gas. (2mk)
- A student found two unlabeled containers with two white solids containing calcium carbonate and sodium carbonate respectively. Describe a test the student would have carried out to confirm the identity of the two solids. (2mk)
 - State the role of carbon (iv) oxide in fire extinguishers. (2mk)
 - In an experiment, 0.8g of magnesium powder was reacted with dilute excess sulphuric (vi) acid at 20⁰c and the time taken recorded. How would you expect the reaction to compare if the experiment was repeated using;
 - Magnesium granules. (1.5mk)
 - At 40⁰ c. (1.5mk)
 - Consider the equilibrium below

$$\text{SO}_{2(g)} + \text{O}_{2(g)} \rightleftharpoons \text{SO}_{3(g)} \quad \text{DH negative}$$
 State any 2 ways in which the yield of SO₃ can be increased. (2mk)
 - In an experiment, 2.3g of zinc powder was added to 30cm³ of 0.5M copper sulphate solution and stirred. The temperature rose by 16.5⁰c.
 - STATE the observations made in the beaker containing copper (ii) sulphate solution. (2mk)
 - Calculate the heat change for the reaction (SHC= 4.2Jg⁻¹k⁻¹ density=1g/cm³) (2mk)
 - Calculate the moles of copper displaced. (1mk)
 - Using the answer in b and c above, calculate the molar heat of displacement of copper (1mk)

CHEMISTRY PAPER 1, 2 & 3

8. The standard electrode potentials of elements P, Q, R, S and T are given below (the letters do not represent the actual symbols of the elements). Study it and answer the questions that follow.

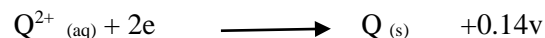
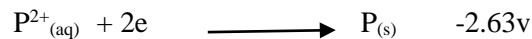

- a) Calculate the EMF of a cell made by combining the half cells of elements R and S. (2mk)
- b) Write the anode equation of an electrochemical cell made by combining the half cells of element T and S. (1mk)
9. Write the electron configuration of the underlined element in the following formulae; SHOW YOUR WORKINGS;
- a) $\text{H}_2\underline{\text{S}}$
- b) $\underline{\text{N}}_2\text{O}$ (1.5mk)
10. Calculate the solubility of a salt X at 25^oc if 8.5grammes of the salt saturates 5g of water at that temperature. (2mk)
11. A form 4 student found a green solid in the lab, on heating a sample of the solid, a black residue and a colorless gas that formed a white precipitate when bubbled into calcium hydroxide solution was formed. On adding dilute sulphuric (vi) acid to the black residue, a blue solution was formed.
- a) Write the formulae of the anion present in the green solid. (1mk)
- b) State and explain using equations where possible the observations that would be made if ammonia solution was added to the blue solution dropwise till in excess. (2mk)
12. DESCRIBE how you can prepare a pure and dry solid sample of lead chloride given the following reagents; dilute hydrochloric acid. solid lead nitrate, sodium carbonate crystals and distilled water (3mk)
13. Dry ammonia was passed over heated copper ii oxide in a combustion tube.
- a) State the observation made in the combustion tube. (1mk)
- b) What mass of the solid product would be formed if 1.59g of copper ii oxide was reacted with excess ammonia gas at room temperature and pressure? (Cu=63.5, O=16) (2mk)
- 14.
- a) State and explain the observation made when chlorine gas is bubbled into a beaker containing moist blue and red litmus papers. (3mk)
- b) Chlorine gas can be prepared in the lab by reacting Manganese (iv) oxide with concentrated hydrochloric acid. Calculate the volume of chlorine gas produced at S.t.p if 0.435g of manganese iv oxide was reacted with excess concentrated hydrochloric acid. (M.G.V =22.4 dm³) (3mk)
- 15.
- a) Define the term allotropes. (1mk)
- b) One of the two allotropes of carbon is graphite. Explain why graphite is used as a lubricant in machines where high temperatures are involved. (1mk)
- 16.
- a) Draw the structural formulae of propanoic acid. (1mk)
- b) Write the name of the compound formed when propanoic acid reacts with butanol. (1mk)
- c) Describe an experiment that can be used to distinguish between ethane and ethene. (2mk)
- 17.
- a) Define the term radioactivity. (1mk)
- b) A radioactive isotope had an original mass of 100grammes decrease to 3.125g in 35 days. Calculate its half-life. (2mk)
18. An element E(not its actual symbol) has a mass number of 35 and 18 neutrons .
- a) What is its atomic number? (1mk)
- b) In which period of the period table is element E? explain your answer (1mk)

CHEMISTRY PAPER 1, 2 & 3

- c) Compare the ionic and atomic radius of element E. (2mk)
- 19.
- a) Aluminium metal is extracted from an ore called bauxite, what is the chemical name of bauxite? (1mk)
- b) Describe the purification of bauxite to acquire pure Aluminium oxide. (3mk)
20. The boiling point of silicon (iv) oxide is much higher than that of sulphur (iv) oxide. Explain this observation. (2mk)
- 21.
- a) Calculate the mass of silver deposited when a current of 1.5 amperes is passed through an electrolytic cell containing silver nitrate solution for one and a half hours. ($A_g=108$, 1 FARADY=96500c) [2mk]
- b) A student wanted to coat an iron spoon with silver, draw and label the set up the student used. (3mk)
22. 80cm^3 of oxygen gas diffused through a porous plug in 50 minutes. If an equal volume of gas Q takes 120 minutes to diffuse through the same plug under the same temperature and pressure, calculate the relative formulae mass of gas Q. (2mk)
23. The lattice energy of calcium chloride is 2237 kJ/mol^{-1} , while the hydration energies of calcium and chloride is 389 kJmol^{-1} and 496 kJmol^{-1} respectively.
- a) Draw an energy cycle diagram linking the enthalpy of solution of calcium chloride and its lattice energy and the hydration energies of calcium and chloride. (2mk)
- b) Calculate the enthalpy of solution of calcium chloride. (2mk)
- 24 Explain the reason why:
- a) The non-luminous flame of a Bunsen burner should always be turned into a luminous flame when not in use. (2mk)
- b) Most laboratory apparatus are made of glass. (2mk)
- c) Cars in Mombasa rust faster than cars in Kisumu. (1mk)

for more free exam papers visit www.freekcsepapers.com

CHEMISTRY PAPER 1, 2 & 3
MURANGA SOUTH
233/2
CHEMISTRY PAPER 2

1. In an experiment, a piece of Magnesium ribbon was cleaned with steel wool. 3.6g of the clean Magnesium metal was put in a crucible and completely burned in oxygen. After cooling the product weighed 60g;
- Explain why it was necessary to clean the Magnesium ribbon. (1mk)
 - What observation was made in the crucible after burning? (1mk)
 - Find the empirical formula of the oxide formed. (2mks)
 - The product in the crucible was shaken with water and filtered. Explain the observation which was made when blue and red litmus papers were dropped into the filtrate. (2mks)
 - Calculate the volume of oxygen used during the burning. (O=16.0, Molar gas volume of a gas = 24,000cm³ at room temperature). (3mks)

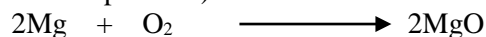

- Compare the melting point of the oxide of magnesium formed above with the melting of sulphur iv oxide. (2mk)

2.

- Alkanes, alkenes and alkynes can be obtained from crude oil. Draw the structure of the second member of the alkyne homologous series. (1mk)

- Study the flow chart below starting with butane and answer the questions that follow;

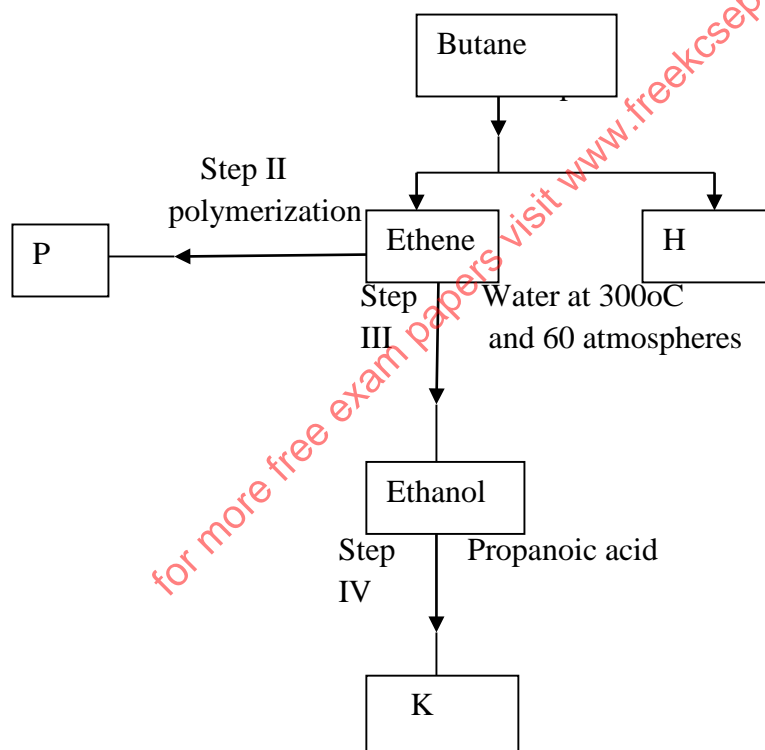

- State the conditions for the reaction in step I to occur. (1mk)
- Identify substance P. (1mk)
- Give:
 - One disadvantage of the continued use of substance such as P. (1mk)
 - The name of the process that takes place in step ;

III

IV

c) The name and formula of substance K. (2mks)

(iv) The relative molecular mass of P is 22,400. Calculate the number of monomers that make up P.

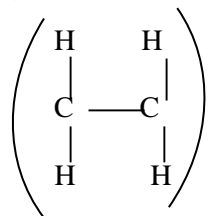

(v) To which homologous series does H belong?

(vi) The table below gives the formula of four compounds H, I, J and K.

Compound	Formula
H	C ₂ H ₆ O
I	C ₃ H ₆
J	C ₃ H ₆ O ₂
K	C ₃ H ₈

Giving a reason in each case, select the letter which represents a compound that:

(a) Decolorizes bromine in the absence of U.V light. (1mks)

(b) Gives effervescence when reacted with aqueous sodium carbonate (1mks)

3. The flow chart below shows some of the processes involved in large scale production of sulphuric (VI) acid. Use it to answer the questions that follows;

Substance A

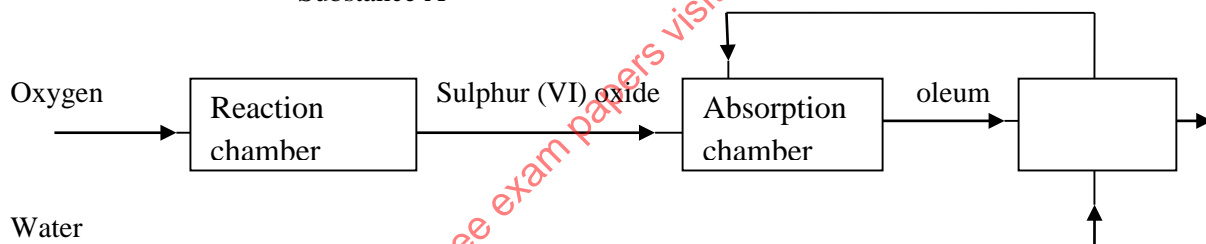

(i) Describe how oxygen is obtained from air on a large scale. (3mks)

(ii) (a) Name substance A. (1mk)

b) Write an equation for the process that takes place in the absorption chamber. (1mk)

(iii) Vanadium (V) oxide is a commonly used catalyst in this process.

(a) Name another catalyst which can be used in this process. (1mk)

(b) Give two reasons why Vanadium (V) oxide is the commonly used catalyst. (2mks)

(iv) State and explain the observations made when concentrated sulphuric (VI) acid is added to crystals of copper (II) sulphate in a beaker. (2mks)

(v) The reaction of concentrated sulphuric (VI) acid with sodium chloride produces hydrogen chloride gas. State the property of concentrated sulphuric (VI) acid illustrated in this reaction. (1mk)

(vi) State four uses of sulphuric (VI) acid. (2mks)

4. (a) What is meant by molar heat of combustion? (1mk)

b) State the Hess's law. (1mk)

(c) Use the following standard enthalpies of combustion of graphite hydrogen and enthalpy of formation of propane. (2mks)

CHEMISTRY PAPER 1, 2 & 3

$$\Delta H_c^\theta (\text{graphite}) = -393\text{KJ/mol}$$

$$\Delta H_c^\theta (\text{H}_2(\text{g})) = -286\text{KJ/mol}$$

$$\Delta H_f^\theta (\text{C}_3\text{H}_8(\text{g})) = -104\text{KJ/mol}$$

- (I) Write the equation for the formation of propane (1mk)
 (II) Draw an energy cycle diagram that links the formation of propane with its heat of combustion and the heats of combustion of graphite and hydrogen. (3mks)
 (III) Calculate the standard heat of combustion of propane. (2mks)
 (d) Other than the enthalpy of combustion, state one factor which should be considered when choosing a fuel. (1mk)
 (e) The molar enthalpies of neutralization for dilute hydrochloric acid and dilute nitric acid are -57.2KJ/Mol while that of ethanoic acid is -55.2KJ/Mol. Explain this observation. (2mks)
 (f) Define the term fuel. (1mk)
- 5.
- (a) An atom W can be represented as ${}_{26}^{53}\text{W}$ what does the number 53 represent. (1mk)
 (b) Study the information in the table below and answer the questions that follow. (The letters are not the actual symbols of the elements)

Element	Electronic arrangement of stable ion	Atomic radius (nm)	Ionic radius (nm)
A	2.8.8	0.197	0.099
B	2.88	0.099	0.181
C	2.8	0.160	0.065
D	2.8	0.186	0.095
E	2	0.152	0.068
F	2.8	0.072	0.136

- (i) Write the formula of the compound when A reacts with B. (1mk)
 (Atomic numbers are A=20, B = 17)
 (ii) Identify which element belongs to the third period of the periodic table. Explain. (2mks)
 (iii) Which of the elements identified in b(ii) above comes first in the third period? Explain. (2mks)
 (iv) Select two elements which are non-metals. (1mk)
- (c) The table below shows the atomic number and first ionization energies of three elements. The letters are not actual symbols of the elements. Use it to answer the questions that follow;

Element	Atomic number	First ionization energy KL/Mol
A	3	519
B	11	494
C	19	418

- (i) Explain the trend in first ionization energy from A to C. (2mks)
 (ii) Write the electronic configuration for the ion of C. (1mk)
 (iii) Explain why C has a lower melting point than B. (1mk)

CHEMISTRY PAPER 1, 2 & 3

6. Study the information given in the table below and answer the questions that follow;

Half reaction	Electrode potential $E^\circ(V)$
$D_{(aq)}^{2+} + 2e \longrightarrow D_{(s)}$	-0.13
$E_{(aq)}^+ + e \longrightarrow E_{(s)}$	+0.80
$F_{(aq)}^{3+} + e \longrightarrow F_{(aq)}^{2+}$	+0.68
$G_{(aq)}^{2+} + 2e \longrightarrow G_{(s)}$	-2.87
$H_{(aq)}^{2+} + 2e \longrightarrow H_{(s)}$	+0.34
$J_{(aq)}^+ + 2e \longrightarrow J_{(s)}$	-2.71

- (i) Construct an electrochemical cell that will be formed when the half cells of elements E and G (3mks)
 (ii) Calculate the e.m.f of the cell constructed in (i) above. (1mks)
 (iii) Why is it not advisable to store a solution containing E^+ ions in a container made of H? (2mks)
- b) During electroplating of an iron spoon, a current of 0.8 amperes was passed through aqueous silver nitrate solution for 2 ½ hours. Calculate the mass of silver that was deposited on the spoon. ($Ag=108.0$, $IF = 96500 C$) (3mks)
- (c) (i) What is meant by electroplating? (1mk)
 ii) State the two purposes of electroplating. (1mk)
7. The table below gives the volumes of the gas produced when different volumes of 2M HCl acid were reacted with 1g of a lump of an alloy of magnesium and copper at room temperature.

Volume 2MHCl acid	Volume of gas produced
0	0
10	240
20	480
30	600
40	600
50	600

- a) Draw the graph of volume of gas produced (vertical axes) against the volume of acid added (3mks)
 b) From the graph, determine;
 (i) The volume of the gas produced if 17.0 cm³ of the acid is used. (1mk)
 (ii) The volume of HCl acid required for reaction completion. (1mk)
 c) Write a balanced chemical equation of the reaction that took place. (1mk)
 d) Calculate the moles of magnesium that reacted (2mks)
 e) Calculate the mass of copper present in the alloy ($Mg=24.0$ $Cu=63.5$). (2mks)

CHEMISTRY PRACTICAL CONFIDENTIAL**233/3**

CONFIDENTIAL: in addition to ordinary lab fittings, each candidate will require

- 1 burette (50ml)
- 1 pipette (25ml)
- 250ml volumetric flask
- Thermometer
- White tile
- 4.5g of solid A
- 100ml of solution B
- 2 labels
- Solid K (about 4.0g)
- 1 spatula(metallic)
- 6 test tube
- 1 boiling tube
- 2 conical flasks
- 2 blue litmus paper and 2 red litmus papers.
- 10ml measuring cylinder.
- Liquid S (about 8ml)
- Universal indicator paper and chart

Access to

- Sodium hydrogen carbonate (solid)
- Bromine water
- 2M Sodium hydroxide solution
- 2M Sulphuric acid
- 0.5M Lead(II) nitrate solution
- 2M dilute Nitric acid
- 2M Barium nitrate solution
- Potassium manganate(VII) solution
- Source of heat

NOTE

1. Solid A is hydrated ethandioic acid(oxalic acid)
2. Solution B is 0.06m acidified KMnO_4 (9.48g/l) made by Dissolving 9.48g of KMnO_4 in 400cm^3 of 2M H_2SO_4 and top up with distilled H_2O
3. Solid K is hydrated magnesium sulphate
4. Liquid S is olive oil

CHEMISTRY PAPER 1, 2 & 3
**MURANGA SOUTH
CHEMISTRY
PAPER 3**

PRACTICAL

You are required to determine the solubility of Solid A at different temperatures and to determine the moles of water of crystallization in Solid A.

You are provided with

- (i) 4.5 g of Solid A in a boiling tube
- (ii) Solution B, 0.06M acidified KMnO_4

PROCEDURE

- (a) Using a burette, add 4cm^3 of distilled water to solid A in the boiling tube. Heat the mixture while stirring with the thermometer to about 70°C . When all the solid has dissolved, allow the solution to cool while stirring with the thermometer. Note the temperature at which crystals of solid A first appear. Record this temperature in table 1.
- (b) Using the burette add 2cm^3 of distilled water to the contents of the boiling tube. Warm the mixture while stirring with the thermometer until all the solid dissolves. Allow the mixture to cool while stirring. Note and record the temperature at which crystals of solid A first appear.
- (c) Repeat procedure (b) two more times and record the temperature in table 1. Retain the contents of boiling tube for use in procedure (e).
- (d) (i) Complete table 1 by calculating the solubility of solid A at different temperatures. The solubility of a substance is the mass of that substance that dissolves in 100cm^3 (100g) of water at a particular temperature.

Table 1

Volume of water in boiling tube (cm ³)	Temperature at which crystals of solid A first appear	Solubility of A in g/100g water
4		
6		
8		
10		

- (ii) On the grid provided, plot the graph of solubility of solid A (vertical axis) against temperature (3mk)
- (iii) Using your graph, determine the temperature at which 100g of solid A would dissolve in 100cm^3 of water. (1mk)
- (e) (i) Transfer the contents of the boiling tube into a 250ml volumetric flask. Rinse both the boiling tube and the thermometer with distilled water and add to the volumetric flask. Add more distilled to make up to the mark. Label this solution A. Fill the burette with solution B. Using a pipette and pipette filler, place 25cm^3 of solution A into a conical flask. Warm the mixture to about 60°C . Titrate the hot solution A with solution B until a permanent pink colour persists. Record your readings in table 2. Repeat the titrations two more times to complete table 2.

Table 2

TITRATION	1	2	3
Final burette reading (cm ³)			
Initial burette reading (cm ³)			
Volume of Solution B used (cm ³)			

(3mks)

(ii) Calculate the;

- (i) Average volume of B used (1mk)
(ii) Number of moles of potassium manganate VII used (1mk)
(iii) Number of moles of A in 250cm³ of solution A, given that 2 moles of potassium manganate VII react completely with 5 moles of A (1mks)
(iv) Relative formula mass of A (3mks)
(v) The formula of A has the form of D.XH₂O. Determine the value of X in the formula given that the relative formula mass of D is 90.0 (O=16.0, H=1.0) (1mk)
2. You are provided with solid K. Carry out the tests below and identify the ions present in K. Record all your observations and inferences

a) Put a spatula end full of solid K in a test tube and heat strongly

Observation (1mk)

Inference(1mk)

b) Put a half spatula of solid K in a test tube and add about 5cm³ of distilled water. Shake the mixture. Divide the solution into four portions of 1 cm³ each

(i) To the first portion add sodium hydroxide solution dropwise until in excess.

Observation(1mk)

Inference(1mk)

(ii) To the second portion add dilute sulphuric acid in drops until in excess

Observation (1mk)

Inference(1mk)

(iii) To the third portion add 2-3 drops of lead (II) nitrate solution

Observation(1mk)

Inference(1mk)

(iv) To the fourth portion add 4 drops of dilute nitric acid followed by barium nitrate

Observation(1mk)

Inference(1mk)

CHEMISTRY PAPER 1, 2 & 3

3. You are provided with liquid S. Carry out the following tests and record your observations and inferences in the space provided.

(a) Scoop a little of liquid S using a clean metallic spatula and burn it in a non-luminous flame of the Bunsen burner.

Observation(1mk)	Inference(1mk)

(b) Put universal indicator paper into a test-tube with liquid S and leave it for sometime

Observation(1mk)	Inference(1mk)

(c) Put 2cm² of liquid S in a test-tube and add a little sodium hydrogen carbonate solid provided and warm. Test any gas provided with red and blue litmus papers

Observation(1mk)	Inference(1mk)

(d) To 2cm³ of potassium manganate(VII) in a test-tube, add an equal volume of liquid S and warm.

Observation(1mk)	Inference(1mk)

(e) Measure 2cm³ of liquid S and add 2cm³ of bromine water in a test tube and shake well.

Observation (1mk)	Inference(1mk)

for more free exam papers visit www.freekccsepapers.com

CHEMISTRY PAPER 1, 2 & 3
MECS CLUSTER JOINT EXAMINATION
233/1
CHEMISTRY PAPER 1 THEORY
TIME: 2 HOURS

- Using reagents provided only, explain how you could prepare a salt of Zinc carbonate solid. Dilute nitric(v) acid, zinc, sodium carbonate (3mks)
- The diagram below shows a Bunsen burner when in use

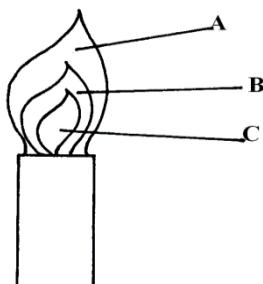

- Describe an experiment that would confirm that region labeled C is unsuitable for heating. (2mks)
- a) On the grid provided sketch a graph of pressure against volume for fixed mass of a gas at constant temperature (1mk)



- b) A fixed mass of a gas has a volume of 250cm^3 at 27°C and 750mmHg pressure.
Calculate the gas volume that the gas would occupy at 41°C and 750mmHg pressure. ($0^\circ = 273\text{k}$) (2mks)
- 22.2cm^3 of sodium hydroxide solution containing 4.0g per litre sodium hydroxide were required for complete neutralisation of 0.1g of a dibasic acid. Calculate the relative formula mass of the dibasic acid. ($\text{Na} = 23$, $\text{O} = 16$, $\text{H} = 1$) (3mks)

5. The diagram below represents a laboratory experiment to investigate the reaction between hydrogen - sulphide gas and an aqueous iron (III) chloride.

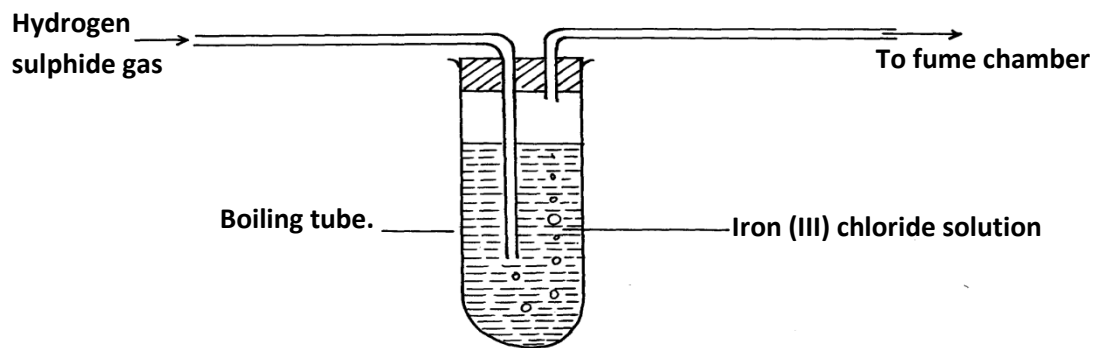

- a) Write chemical equation for the reaction which takes place in the boiling tube. (1mk)
- b) What adjustment need to be made in the above set-up if the laboratory does not have a fume chamber. (1mk)
- c) Describe a laboratory chemical test for a sample of hydrogen sulphide gas. (1mk)
6. A group of compounds called chlorofluorocarbons have a wide range of uses but they have harmful effects on the environment. State and explain one harmful effect of chlorofluorocarbons on the environment. (2mks)
7. X grams of a radioactive isotope takes 120 days to decay to 3.5 grams. The half-life period of the isotope is 20 days.
- a) Calculate the initial mass of the isotope (2mks)
- b) State the application of radioactivity in agriculture. (1mk)
8. Sulphur and sodium belong to the same period on the periodic table. State and explain the difference in M.P of the oxide of sulphur and the oxide of sodium. (3mks)
9. a) Water is an example of a polar solvent. What is a polar solvent? (1mk)
- b) Explain the following observations HCl gas dissolves in water to form an electrolyte, while the same chloride dissolves in methylbenzene to form a non-electrolyte (1mk)
10. a) Define the term deposition (1mk)
- b) Describe how you can obtain copper powder from a mixture containing copper and zinc powder. (2mks)
11. a) Name the main ore from which iron is extracted. (1mk)
- b) Name two substances that convert iron (III) oxide to iron in the blast furnace. (2mks)
12. a) Write an equation showing how boiling can remove temporary water hardness. (1mk)
- b) Name one method that can be used to remove both temporally and permanent water hardness. (1mk)
- c) Other than wastage of soap during cleaning, state one other disadvantage of hard water. (1mk)
13. a) Name two pure allotropes of carbon. (1mk)
- b) State and explain using relevant equations the observation made when carbon(IV) oxide is bubbled through calcium hydroxide solution for a long time. (2mks)
14. When $\text{Na}_2\text{CO}_3 \cdot x\text{H}_2\text{O}$ is strongly heated it loses 63.2% of its mass. Determine the value of x in the compound (Na = 23, O = 16, H = 1) (3mks)

15. Dry ammonia was passed over a heated lead(II) oxide in a combustion tube as shown

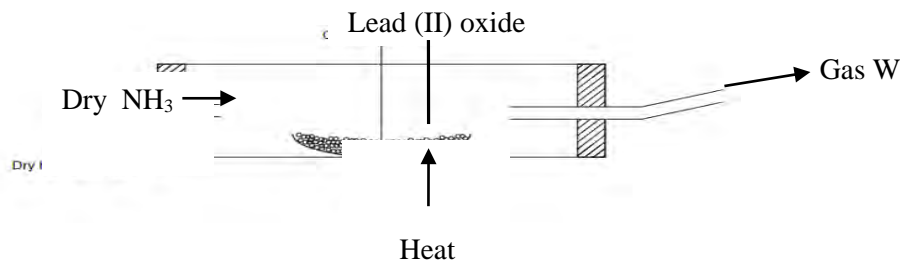

- What observations would be made in the combustion tube (1mk)
 - Write a chemical equation for the reaction in the combustion tube (1mk)
 - State one industrial use of ammonia (1mk)
16. An ion of P²⁺ has a configuration of 2.8
- Name the family to which P belong (1mk)
 - Compare the atomic and ionic radius of P. Explain (2mks)
17. a) Explain why alkanes are used as fuel (1mk)
- b) Draw the structure of the following compounds (2mks)
- 3-methylbut – 1 yne
 - But – 2 – ene
18. a) Define solubility (1mk)

b) Study the information in the table and answer the questions below

Salt	Solubility (g) 100g water	
	At 40°C	At 60°C
CUSO ₄	28	38
Pb(NO ₃) ₂	79	98

- Calculate the mass of CuSO₄ that would saturate 200g of water at 60°C (1mk)
 - A solution containing 80g of Pb(NO₃)₂ in 100g of water at 60°C was cooled to 40°C. Calculate the mass of Pb(NO₃)₂ that crystallized (1mk)
19. Dilute hydrochloric acid was added to a compound Z of copper. The solid reacted with the acid to form a colourless gas which formed a white precipitate when bubbled through lime water.
- Name solid Z (1mk)
 - State the observation that would be made if a similar compound of lead is used. Explain. (2mks)
20. a) Explain why the reactivity of group(VII) elements decrease down the group (2mks)
- b) Moist blue litmus and dry blue litmus paper were introduced into gas jars of dry chlorine. State the observations that would be made. (1mk)
21. a) Name the reagents that are commonly used in the preparation of hydrogen (1mk)

b) Study the diagram below and answer the questions that follow

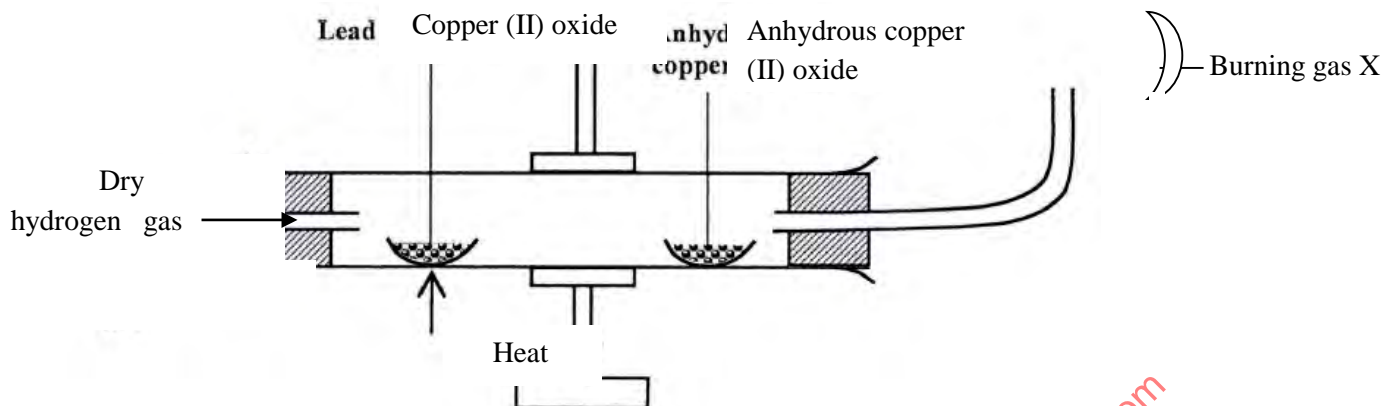

- i) Name gas x (1mk)
- ii) State and explain the observation made in the anhydrous copper(II) sulphate after sometime (1mk)

22. a) State two physical properties of sulphur (IV) oxide (1mk)

b) Explain why when sulphur (IV) oxide is bubbled into acidified potassium dichromate (VI) the solution changes colour from orange to green. Explain the observation (1mk)

c) In the contact process of manufacture of sulphuric(VI) acid, explain how pollution by SO₂ is reduced. (1mk)

23. Study the setup below and answer questions that follow

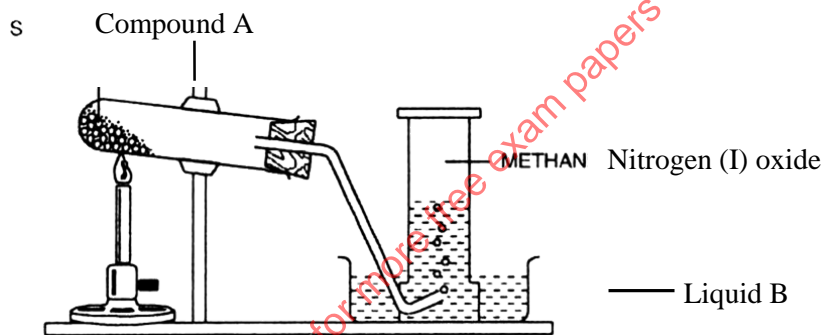

- a) Name (1mk)
 - i) Compound A

ii) Liquid B

b) Why is the boiling tube tilted downwards (1mk)

24. Explain why

- a) Aluminium is commonly used for making cooking pots and pans. (1mk)
- b) Silicon(IV) oxide is a poor conductor of heat and electricity (1mk)

25. The set up below was used to show electrolysis in molten lead(II) iodide

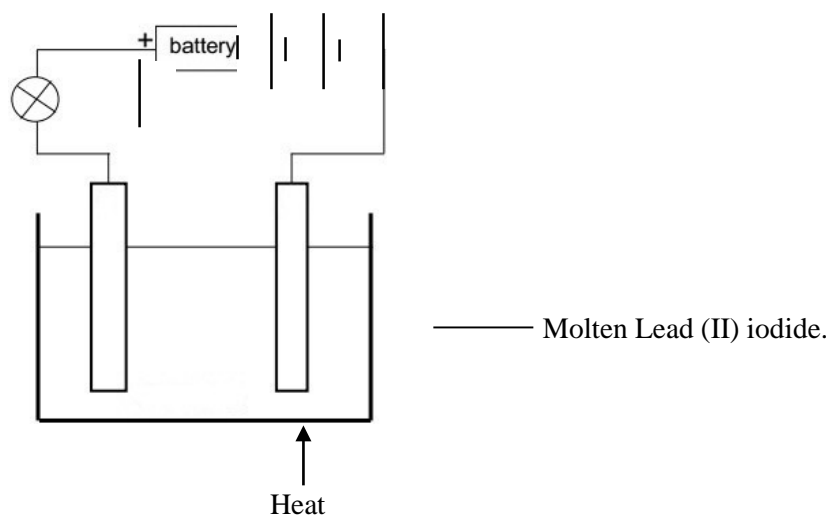

- i) On the diagram label the cathode (1mk)
- ii) State the observation that was made at the anode during the electrolysis. Give a reason for your answer (2mks)

26. 100cm^3 of carbon (II) oxide gas was reacted with 100cm^3 of oxygen. (All volume were measured under the same conditions of temple and pressure.

- a) Determine
- i) Volume of the product formed (1mk)
- ii) The gas which was in excess and by what volume (2mks)

27.a) Using a dot(.) and cross(x) diagram of carbon(II) oxide, differentiate between a covalent and a co-ordinate bond (1mk)

b) Use dot (.) and cross(x) diagrams to show bonding in between the elements represented by the following symbols. (2mks)

- i) ${}_{12}^{24}\text{X}$ and ${}_{9}^{19}\text{Y}$

28. Study the flow diagram below

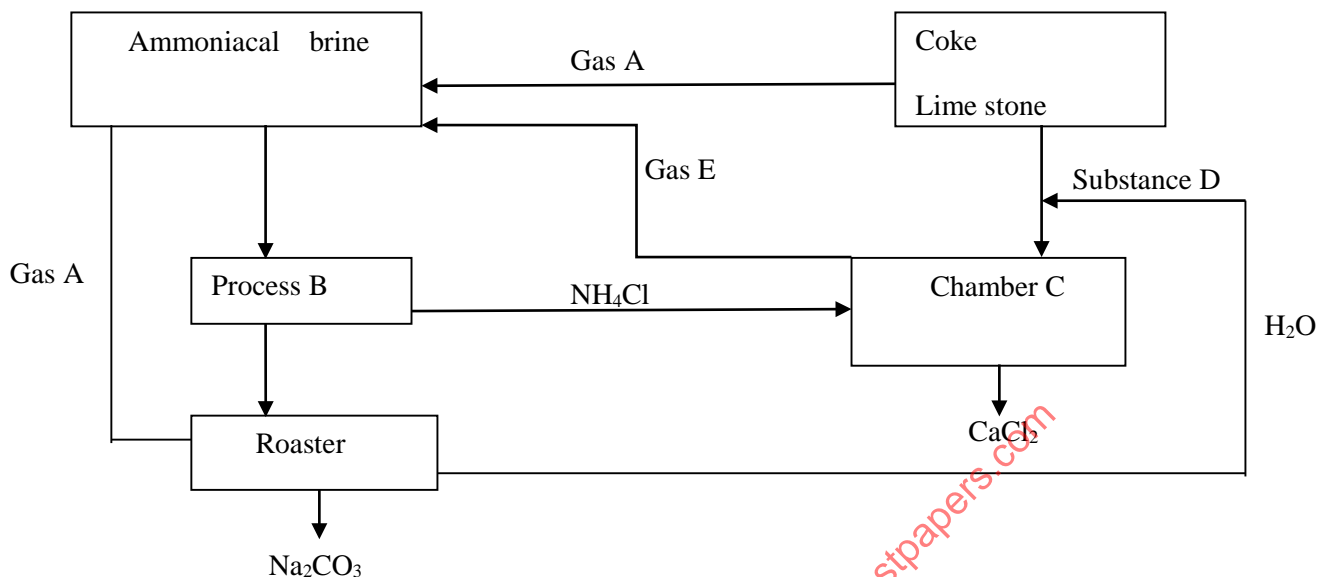

a) Name

- i) Gas A (½ mk)
 - ii) Process B (½ mk)
 - iii) Substance D (½ mk)
 - iv) Gas E (½ mk)
- b) Write the equation for the reaction in chamber C (1mk)

**MURANGA EXTRA COUNTY SCHOOLS END OF TERM TWO EXAMINATIONS
CHEMISTRY PAPER TWO
233/2**

1 a). A form one student set up the following experiment. Study the diagrams and use them to answer the questions that follow.

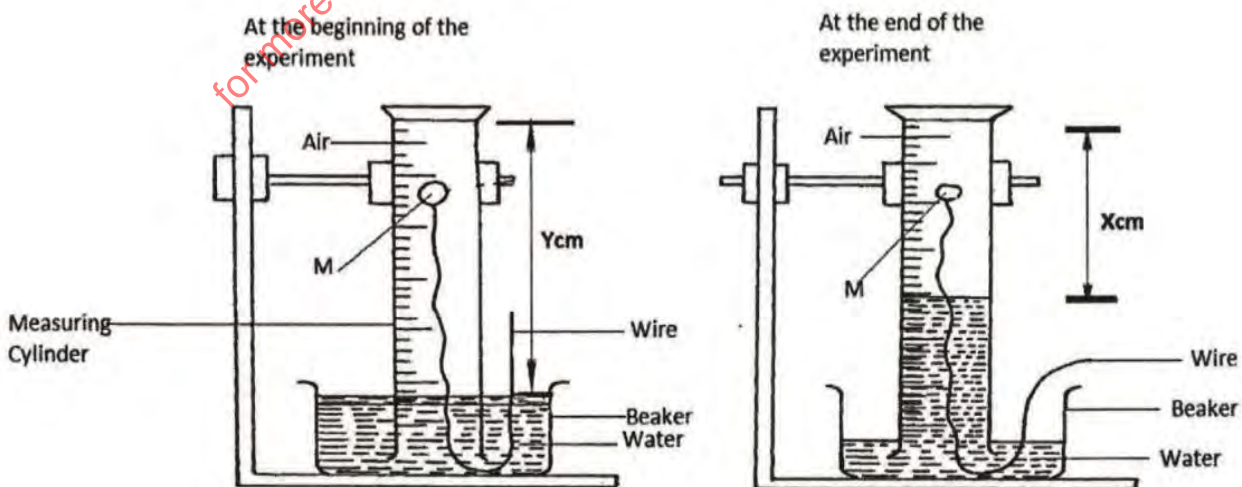

i) Describe what the student was investigating

(1 mark)

CHEMISTRY PAPER 1, 2 & 3

- ii) Identify substance M _____ (1 mark)
 iii) Explain how the student arrived at the conclusion in the above experiment (2 marks)
 iv) Write down two uses of oxygen gas (1 mark)
- b) The above apparatus were used in the preparation of various gases in the laboratory. Use the setup to answer the questions that follow.

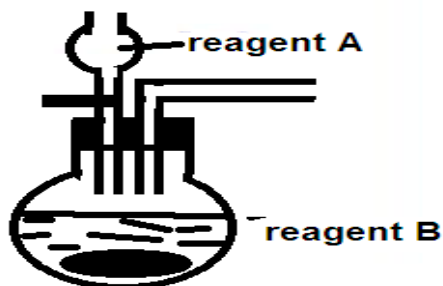

- i) Identify reagent A or reagent B used in the preparation of the following gases according to the table below. (2 mark)

Gas	Hydrogen	Oxygen	Carbon IV oxide	Sulphur IV oxide
Reagent A	Dilute sulphuric VI acid			Dilute sulphuric VI acid
Reagent B		Sodium peroxide	Calcium carbonate	

- ii) Complete the diagram to show how a dry sample of hydrogen gas is collected (3marks)
 iii) Write a balanced equation for the above reaction in the preparation of sulphur (IV) oxide gas. (1 mark)

2. Study the information below given about elements P, Q, R, S, T, and U, which form part of the Periodic Table. Letters are not actual symbols of the elements.

- Elements P, S and R are in period 2. The ion of P and S are P^{+1} and S^{-1} respectively. R has the highest ionization energy.
- T^{+3} has a configuration of 2:8 and a relative atomic mass of 27
- Q gains two electrons to attain a noble gas configuration and is in the same period as T
- U is a transitional element in period 4.

Use the information above to answer the questions that follow.

- a) Identify the respective positions of the elements in the grid above (3marks)
 b) Which element forms ions with a charge of -2? (1mark)
 c) How does the reactivity S compare with that of chlorine? Explain. (2 marks)

CHEMISTRY PAPER 1, 2 & 3

- d) using a dot and cross diagram show the ionic structure of T (1 mark)
- e) Compare the atomic radii of elements T and Q. Explain (2 marks)
- f) If the oxides of P and S are separately dissolved in water, state and explain the effects of their aqueous solutions on both blue and red litmus papers. (2 marks)
- g) Identify the structure formed when the following elements form compounds (1 mark)
- i) Element Q and P _____
- ii) Two atoms of element S _____ (1 mark)

3. a) Study the structures below and answer the questions that follow

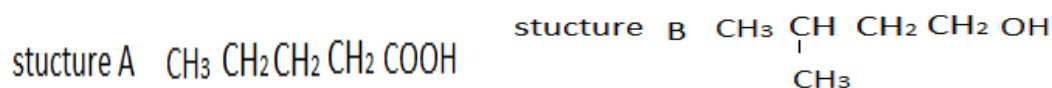

- i. Name structures A and B (2marks)
- ii. Describe how substances A and B be distinguished in the laboratory. (2marks)
- b) Prop-1-ene undergoes a reaction X to form propan-1-ol. Propan-1-ol undergoes reaction Y to form $\text{C}_2\text{H}_5\text{COOH}$. When $\text{C}_2\text{H}_5\text{COOH}$ is reacted with sodium carbonate it forms $\text{C}_2\text{H}_5\text{COONa}$, carbon IV oxide and water are formed. $\text{C}_2\text{H}_5\text{COONa}$ is reacted with soda lime to form an organic compound K. (1 mark)
- i. Identify organic compound K _____
- ii. Identify one reagent that can be used in Reaction X (1 mark)

Reaction Y _____ (

c) The structures below represent two cleansing agents Q and R. Study it and answer the questions that follow.



- i) Identify one disadvantage of use of Q (1 mark)
- ii) Which two raw reagents are used in the preparation of R (1 mark)
- ii) Describe how a cleansing agent removes grease form a piece of cloth. (2 marks)
- d) Tetrafloroethene is a monomer that is used in the manufacture of Teflon. Show two repeated units of Teflon (2 marks)
4. Below is a simplified diagram of the Downs Cell used for the manufacture of sodium from Rock salt. Study it and answer the questions that follow

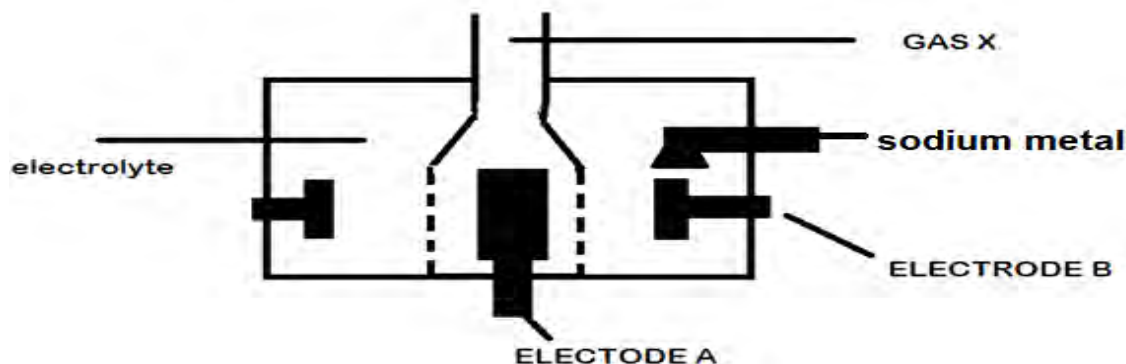

CHEMISTRY PAPER 1, 2 & 3

- i. Identify the electrode where reduction takes place in the cell above (1 mark)
 - ii. Write an ionic equation for the reaction in which gas X is formed (1 mark)
 - iii. Explain two observations made when a piece of sodium metal is placed on a water trough (2 mark).
 - iv. The main electrolyte is molten Rock salt. Why is it not advisable to use sea water in this process? (2 marks)
 - v. Substance Y is added to lower the melting point of sodium chloride from about 800°C to about 600°C. Identify substance Y and give a reason as to why it is added (1 mark)
 - vi. The above cell ran for one day and 21.4 hours nonstop and a current of 1500 amp was used. Calculate the mass of sodium produced to the nearest Kg (1F=96500C Na= 23, Cl= 37.5) (3 marks)
 - vii. To prepare bleaching agent chlorine gas is bubbled in a solution of sodium hydroxide. Write a balanced equation for the above reaction. (1 mark).
5. a) State two factors that should be considered when choosing fuel for cooking (2marks)
- b) Define the term molar heat of combustion (1mark)

c) The diagram below represents a set – up that was used to determine the molar heat of combustion of butanol. 250ml of water was heated from 225K to 295K .the mass of butanol and lamp initially was 154.4g and dropped to 124.8g after the experiment

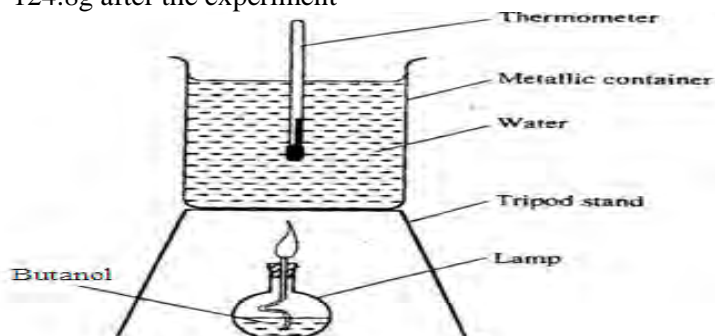

Calculate the:

- (i) Molar heat of combustion of butanol (C = 12.0, O = 16.0, H=1.0) Specific heat capacity of water = 4.2 Jg⁻¹K⁻¹(density of water = 1g/cm³) (3marks)
- (ii) Heating value of butanol. (1 mark)

CHEMISTRY PAPER 1, 2 & 3

d) Using the information below determine the heat of combustion of butanol using the following data and represent the above information on an energy cycle diagram

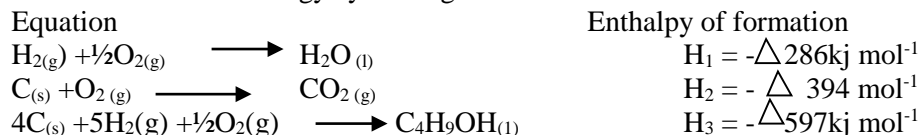

(3marks)

6. The equation below show the catalytic oxidation of sulphur IV oxide



An equilibrium is achieved when 39% of $\text{SO}_2(\text{g})$ is converted to SO_3 at a pressure of 12.5Kpa and temperature of 460°C . The graph represents the reaction pathway achieved by the reaction. Vanadium (v) oxide catalyst is used in the above reaction

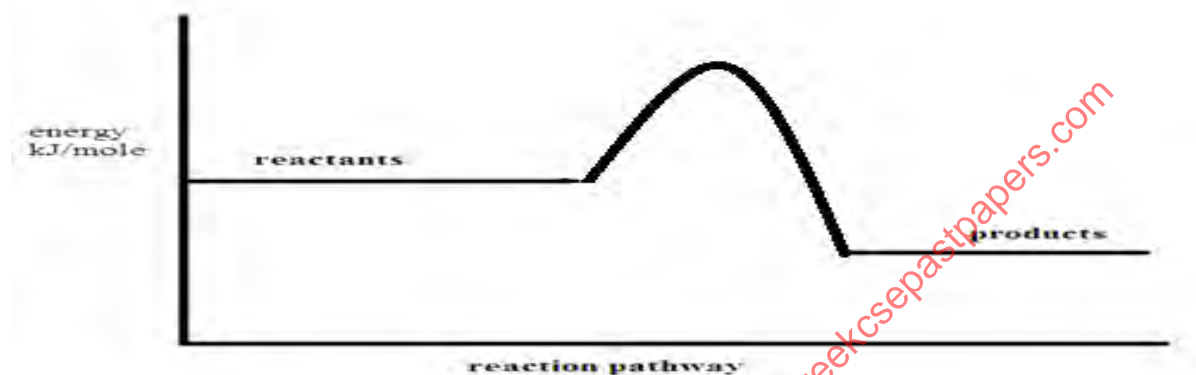

a) Is the reaction endothermic or exothermic? Explain

(2mark)

b) Give reasons on how the yield of sulphur (VI) oxide would be affected if

i. pressure would be lowered to 8.5kPa

(2marks)

ii. temperature is lowered to 200°C

(2marks)

iii. Addition of concentrated sulphuric VI acid.

(2marks)

c) On the same axis, plot a graph that would be achieved if the vanadium (v) oxide catalyst was not used (1mark)

d) Describe how is sulphuric (VI) acid is formed from the SO_3 gas using equations

(2marks)

7. a) Use the information below and answer the questions that follow. The letters are not the actual symbols of the elements.

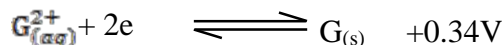
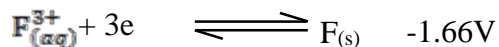
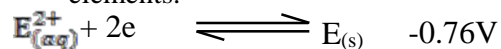

a) Draw a well labeled diagram of an electrochemical cell that would give the highest E^θ value

(2marks).

b) Calculate the EMF of the given cell in (a) above

(1/2 marks).

c) On the diagram indicate the flow of electrons

(1/2 marks).

b) A current of 6amp was passed over 200ml of 5M copper chloride solution with graphite electrodes. After two hours the graphite electrodes were replaced with copper electrodes.

i) Explain the observations at the anode using relevant equations when graphite electrodes were used. (2marks)

- ii) Explain the reaction that occurred on the anode with the change in electrodes (1mark)
- c) 4.5 g of metal A, B, and C were added to 100ml of 0.5M solution of copper sulphate in three separate beakers. The temperature of the solutions was recorded before and after the experiment and the temperature recorded in the table below.

Metal	A	B	C
Initial temperature in °C	25	26	26
Final temperature in °C	38	30	26

- i) Apart from increase in temperature identify one other observation made in beakers containing metals A and B (1mark)
- ii) Why was there no change in temperature in metal C (1mark)
- iii) Write an ionic equation for the reaction between A and copper metal. Given that metal A is divalent (1mark)
- iv) Explain what happens when a solution of ions of metal C is stored in a container made of metal B. (2mark)

CONFIDENTIAL INSTRUCTIONS

In addition to the apparatus and reagents found in a Chemistry laboratory each candidate will require the following

- About 50cm³ of solution B
- About 150cm³ of solution C
- One pipette 25ml
- One pipette filler
- One burette 0 - 50ml
- Two conical flasks - 250ml
- One 10ml measuring cylinder
- One 100ml measuring cylinder
- 100ml empty beaker
- 250ml volumetric flask
- Six test tubes
- One thermometer -10⁰C to 110⁰C
- One boiling tube
- About 500cm³ of distilled water supplied in a wash bottle
- Two labels
- About 1g of solid F in a stoppered container
- About 0.2g of solid sodium hydrogen carbonate
- One blue and one red litmus paper
- About 6cm³ of liquid P
- Test tube holder

Access solution

- Acidified lead (II) nitrate supplied with a dropper.
- Aqueous Barium (II) chloride supplied with a dropper.
- Phenolphthalein supplied with a dropper.
- Acidified potassium dichromate (VI) supplied with a dropper

CHEMISTRY PAPER 1, 2 & 3

- 5) Bunsen burner
- 6) Sodium hydroxide solution
- 7) Hydrogen peroxide

Solutions preparations

1. Solution C is prepared by dissolving 6.87cm^3 of concentrated sulphuric (VI) acid in 200cm^3 of distilled water and made up to 1000cm^3 of solution with distilled water. Label this as solution C.
2. Solution B is prepared by dissolving 80g of NaOH in about 600cm^3 of distilled water and diluting to one litre of solution. Label this as solution B.
3. Barium chloride is prepared by dissolving 30g of solid Barium chloride in about 600cm^3 of distilled water and diluting to one litre of solution. Label this as aqueous barium nitrate.
4. Acidified potassium dichromate (VI) is prepared by dissolving 25g of potassium dichromate (VI) crystals in about 200cm^3 of 2M sulphuric (VI) and diluting with distilled water to one litre of solution.
5. Liquid P : Ethanol
6. Solid F: iron (II) Sulphate

**MURANGA EXTRA COUNTY SCHOOLS (MECS)
END OF TERM TWO EXAMINATION
CHEMISTRY
PAPER 3**

1.a) You are provided with

- 2.0M sodium hydroxide solution labelled solution B
- Solution C containing 12.25 g per litre of a mineral acid C

You are required to

- i) Prepare a dilute solution of sodium hydroxide, solution B.
- ii) Determine the

Relative Formula mass of the acid C

Molar Enthalpy change of reaction between acid C and sodium hydroxide solution B.

Procedure 1.

Using a pipette and a pipette filler place 25.0cm^3 of solution B in a 250.0ml volumetric flask. Add to it about 150cm^3 of distilled water. Shake well. Add more distilled water to make up to the mark. Label this solution D

CHEMISTRY PAPER 1, 2 & 3

Fill a burette with solution C. Using a clean pipette and a pipette filler, place 25.0cm³ of solution D into a 250ml conical flask. Add two drops of phenolphthalein indicator and titrate with solution C. Record your results in table 1. Repeat the titration two more times and complete the table. (4 marks)

	1	2	3
Final burette reading (cm ³)			
Initial burette reading (cm ³)			
Volume of solution C used (cm ³)			

Calculate:

- Average volume of solution C used. (1 mark)
- Moles of solution D used. (2 marks)
- Concentration in moles per litre of acid in solution C given that the number of moles of acid C used are half the moles of D used. (2 marks)
- Relative formula mass (RFM) of solution C. (1 mark)

b) PROCEDURE II.

- Using a clean burette, place 5.0cm³ of solution C into each of six (6) test-tubes.
- Using a 100ml measuring cylinder, place 20cm³ of solution D, sodium hydroxide solution in a 100ml plastic beaker. Measure the temperature of solution D and record it in table 2 below.
- To solution D in the beaker, add acid C, solution C from one of the test-tubes. Stir the mixture with the thermometer and record in Table 2, the maximum temperature reached. Continue with step (iv) IMMEDIATE
- Add the acid C, solution C from another test-tube to the mixture obtained in (iii) above, stir and record the maximum temperature reached in Table 2. Continue adding the acid C, solution C from each of the other four test-tubes, stirring the mixture and recording the maximum temperature each time and complete Table 2.

TABLE 2 (4 marks)

Volume of solution C acid C added (cm ³)	0	5	10	15	20	25	30
Maximum temperature (°C)							

- On the grid provided, plot a graph of temperature (vertical axis) against volume of acid C solution C added.

(3 marks)

d) Using the graph

i. Determine the volume of solution C which gave the maximum change in temperature. (1 mark)

ii. Determine the temperature change for the reaction. (1 mark)

e) Using your answer in parts d (i) and d(ii), calculate the molar enthalpy change of the neutralisation reaction between acid C and sodium hydroxide solution.

(Heat capacity = $4.2\text{J g}^{-1}\text{K}^{-1}$; density of the mixture = 1.0gcm^{-3})

(3 marks)

2. a) You are provided with solid F carry out the following tests write your observations and inferences in the spaces provided.

i) Place a half spatula and full of solid F in a dry test tube and heat strongly. Test the gases produced with litmus paper

Observations	Inferences
(1mark)	(1 mark)

ii) Place the remaining solid F in a boiling tube and add 10cm^3 of distilled water. Divide the resulting solution into five portions

Observations	Inferences
(1 mark)	(1 mark)

iii) To the first portion, add sodium hydroxide solution drop wise until in excess.

Observations	Inferences
(1mark)	(1 mark)

iv) To the second portion, add 5 drops of the hydrogen peroxide and then add ammonia solution drop wise until in excess.

Observations	Inferences
(1 ½ mark)	(½ mark)

v) To the third portion, add three drops of acidified lead (II) nitrate solution.

Observations	Inferences
(1 mark)	(1mark)

vi) To the fourth portion, add three drops of barium nitrate solution.

Observations	Inferences
(1 mark)	(1 mark)

3. You are provided with an organic liquid P. Carry out the following tests and record you observations and inferences in the space provided.

a) Place about 4cm^3 of liquid P in a boiling tube. Add to it 10cm^3 of distilled water and shake well.

CHEMISTRY PAPER 1, 2 & 3

Label this solution G.

Observations	Inferences
(1 mark)	(1 mark)

b) Place 2cm³ of solution G in a test-tube. Add to it solid sodium hydrogen carbonate provided.

Observations	Inferences
(1 mark)	(1 mark)

c) To a second 2cm³ portion of solution G in a test-tube, add 2 to 3 drops of acidified potassium dichromate (VI) and warm.

Observations	Inferences
(1 mark)	(1 mark)

for more free exam papers visit www.freekcsepastpapers.com