

NAME: ..... CLASS: ..... ADM. NO. ....

SIGNATURE: .....

DATE: .....

**441/2**  
**HOME SCIENCE (CLOTHING CONSTRUCTION)**  
**PAPER 2**  
**PRACTICAL**  
**SEPTEMBER, 2021**  
**Time: 2 ½ hours**

**KASSU JOINT EXAMINATION**  
**Kenya Certificate of Secondary Education**  
**HOME SCIENCE**  
**(CLOTHING CONSTRUCTION)**  
**PAPER 2**  
**PRACTICAL**  
**TIME: 2 ½ HOURS**

**Instructions to candidates**

- *This paper consists of 3 printed pages.*
- *Candidates should check the question paper to ascertain that all pages are printed and no questions are missing.*

A pattern of a girl's skirt is provided. You are advised to study sketches, instructions and layout carefully before you begin the test.

1. Materials provided.
  - A Skirt Back
  - B Skirt Front
  - C Front Yoke
  - D Front frill
  - E Back Frill
  - F Waist band
  - G Pocket
2. Plain light weight fabric 55cm long by 90cm wide.
3. Sewing thread to match the fabric
4. One large A4 envelope.

### **The test**

Using the materials provided, lay, cut and make the **LEFT HALF** to show the following processes;

- (a) Cutting out **(18marks)**
- (b) Making the dart at the back skirt. **(5marks)**
- (c) Joining the front yoke to the front skirt using overlaid seam. **(10<sup>1</sup>/<sub>2</sub>marks)**.
- (d) Attaching the in-seam pocket. **(7marks)**
- (e) Making the side seam using open seam. Neaten the lower part of the seam only. **(6<sup>1</sup>/<sub>2</sub>marks)**
- (f) Joining the front frill to the back frill using double stitched seam. **(7marks)**.
- (g) Attach the lower part of the skirt to the joined frills using plain seam. Neaten the back part only. **(7marks)**
- (h) Preparing and attaching an **INTERFACED** waist band. Neaten using hemming stitches. **(13marks)**
- (i) Making the button hole. **(10marks)**
- (j) Presentation. **(6marks)**

**LAYOUT (NOT DRAWN TO SCALE)**

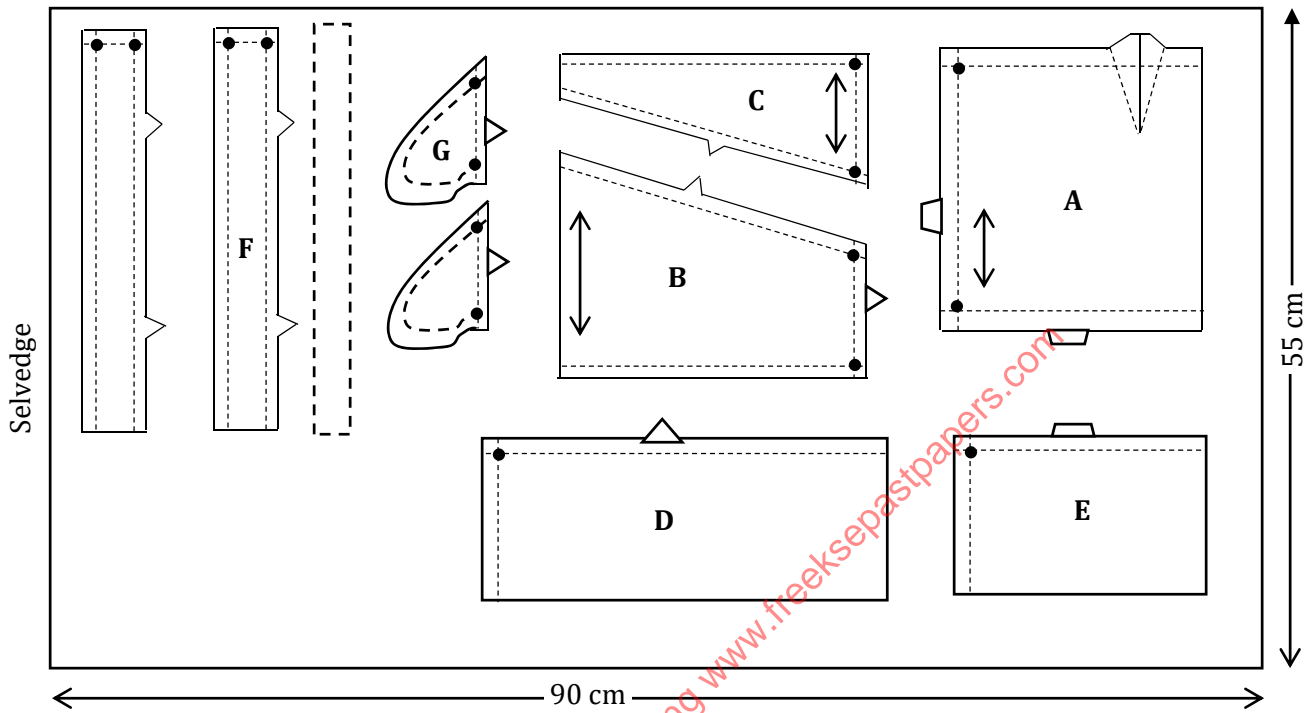

**VIEWS**

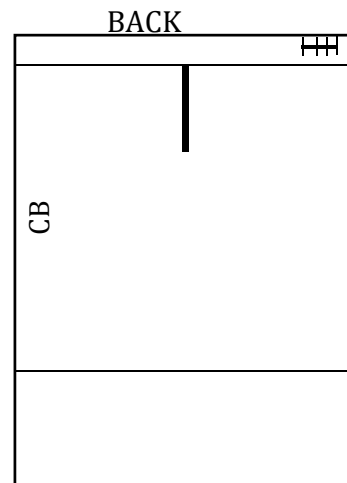
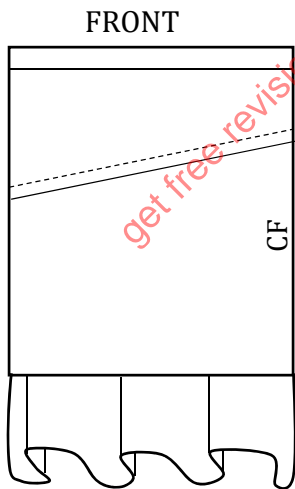

get free revision content by visiting [www.freeksepastpapers.com](http://www.freeksepastpapers.com)