

CICT PART I SECTION 2

COMPUTER SUPPORT AND MAINTENANCE

WEDNESDAY: 25 November 2020.

Time Allowed: 3 hours.

Answer ALL questions. Marks allocated to each question are shown at the end of the question.

QUESTION ONE

(a) Explain the function of each of the following types of firewalls:

(i) Packet-filtering firewall.

(2 marks)

(ii) Stateful inspection firewall.

(2 marks)

(b) The diagram below shows a magnetic disk platter:

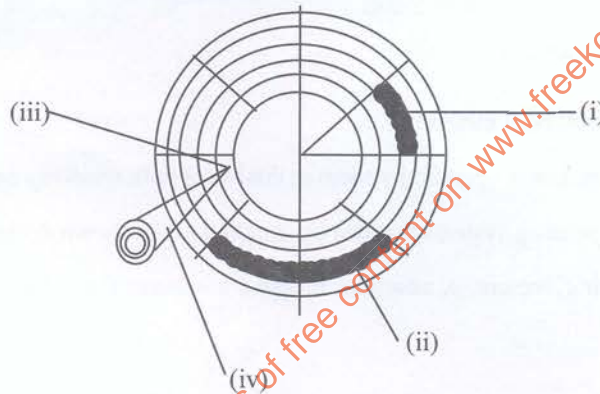

Required:

Name the parts labelled (i) to (iv) in the diagram above.

(4 marks)

(c) Propose three characteristics of each of the following computer power management features:

(i) System hibernate.

(3 marks)

(ii) System standby.

(3 marks)

(d) On booting up a computer in the morning, Jasper Moroni received an error message: "Missing operating system" on the blank screen.

Required:

Analyse six possible causes of the above problem.

(6 marks)

(Total: 20 marks)

QUESTION TWO

(a) Analyse the impact of each of the following to the central processing unit (CPU):

(i) Increasing the number of cores.

(2 marks)

(ii) Increasing the cache size

(2 marks)

- (b) (i) List three types of cargo carried through the motherboard embedded wires that make up a bus. (3 marks)
- (ii) Explain two differences between traditional computer motherboard and laptop or smartphone or tablet logic board. (4 marks)
- (c) Suggest five circumstances under which an organisation might consider conducting urgent computer maintenance exercise for all its computers. (5 marks)
- (d) Propose two circumstances under which the computer main memory would be replaced. (4 marks)

(Total: 20 marks)

QUESTION THREE

- (a) Marion Mchesi's computer is slow in loading programs and she has approached you for assistance. You discover that she has never run the clean-up utility.

Required:

Highlight four files targeted by the clean-up utility.

(4 marks)

- (b) Consider the Figure 1 below. You intend to install Linux operating system alongside already installed windows operating system.



(Figure1)

Required:

- (i) Describe operations of the dual boot method. (2 marks)
- (ii) Outline the steps of installing Linux operating system in dual boot with windows operating system. (6 marks)
- (iii) Determine the number of operating systems that can be installed in the shown drives. (2 marks)
- (c) You own a personal computer repair company. A customer brings a computer that does not boot. You discover the hard disk has failed.

Required:

- (i) Examine three common symptoms of impending hard disk failure. (3 marks)
- (ii) Suggest three ways of fixing the hard disk problems. (3 marks)

(Total: 20 marks)

QUESTION FOUR

- (a) Describe each of the following types of computer monitor overlay:

- (i) Video overlay. (2 marks)
- (ii) Hardware overlay. (2 marks)
- (iii) Overlay network. (2 marks)

- (b) (i) Define 3 – 2 – 1 computer data backup rule. (2 marks)
- (ii) Differentiate between “local backup” and “offsite backup” as used in computer security. (4 marks)

- (c) One of the computers in the office requires BIOS update to continue functioning well. As a computer specialist, you have been requested to fix the problem.

Required:

Analyse five precautions you would take before upgrading the BIOS.

(5 marks)

- (d) Assess three factors to consider in choosing the right stand for a flat computer monitor.

(3 marks)

(Total: 20 marks)

QUESTION FIVE

- (a) (i) Summarise three risks of buying a refurbished laptop. (3 marks)
- (ii) Examine five steps a technician could follow during a laptop refurbishment process. (5 marks)
- (b) Mercy Ratemo's attempt to print a document failed, instead she got an error message from her computer "printer drivers are missing".

Required:

- (i) Explain the meaning of "printer drivers". (1 mark)
- (ii) Advise her on three sources of printer drivers. (3 marks)
- (c) Suggest two advantages and two disadvantages of purchasing a computer as compared to leasing. (4 marks)
- (d) Citing two reasons, justify the need for online computer technical support for small businesses. (4 marks)

(Total: 20 marks)

.....

access thousands of free content on www.freekcsepastpapers.com