

Name Index No. Adm. No.....

SchoolCandidate's signature

Date

449/1

DRAWING AND DESIGN

Paper 1

June 2022

BUNAMFAN CLUSTER EXAMINATIONS

Kenya Certificate of Secondary Education

DRAWING AND DESIGN

Paper - 449/1

Time: 2½ hours

INSTRUCTIONS TO CANDIDATES

- You should have the following materials for this examination.
 - Drawing instruments.
 - 3 sheets of drawing paper size A3
- This paper consists of three sections A, B and C.
- Answer ALL the questions in section A and B and any two questions from section C.
- Question in Section A must be answered on the answer sheets provided.
- Question in section B and C should be answered on the A3 sheet of the drawing paper provided.
- All dimensions are in millimetres unless otherwise stated.
- Candidates may be penalized for not following the instructions given in this paper.
- Candidates should check to questions paper to ascertain that all the pages are printed as indicated and that no questions are missing.

FOR EXAMINER'S USE ONLY

Section	Question	Maximum	Candidate's score
A	1 - 10	50	
B	11	20	
C	12	15	
	13	15	
	14	15	
TOTAL SCORE 100%			

This paper consists of 7 printed pages

Candidates should check the question paper to ensure that all the printed pages are printed as indicated and no questions are missing.

SECTION A (50 marks)

Answer ALL the questions in this section in the spaces provided.

1. Explain technical drawing as means of communication. (2 marks)

.....
.....
.....
.....
.....
.....

2. (a). Name **three** types of lines and specify the pencil grade to be used in each case. (3 marks)

(i).
.....
(ii).
.....
(iii).
.....

(b). State **four** computer Softwares used technical drawing. (2 marks)

(i).
(ii).
(iii).
(iv).

3. a) By use of neat diagram, show how an A0 drawing paper can be sub-divided to generate paper sizes A1, A2 and A3. (3 marks)

visit www.freekcsepastpapers.com to download free resources

b) State **three** factors to be considered while lettering. (3 marks)

(i).
(ii).
(iii).

4. Use standard symbols and abbreviations to represent each of the following: (4 marks)

- i) Cylinder
- ii) Machined surface.

5. Construct a triangle ABC whose sides are in the ratio 3 : 4 : 6 given the length of 110mm and measure the smallest angle. (5 marks)

6. Construct a diagonal scale of 3 : 1 having an accuracy of 0.1mm to read to a maximum of 40mm. Show a reading of 28.3mm (6 marks)

visit www.freekcepastpapers.com to download free resources

7. Figure 1 shows the layout of a crank mechanism. Draw the locus of point C for one revolution of crank OB. End A of link AB moves along the horizontal centre line. (6 marks)

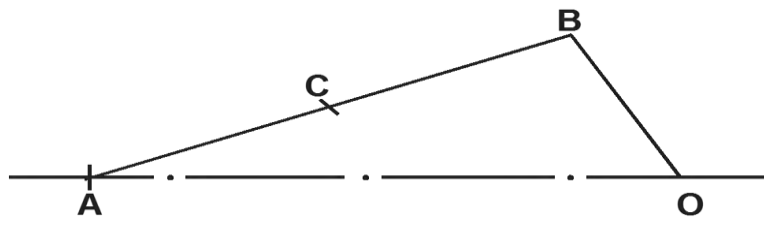

Fig 1

8. Using a ruler and pair of compasses only, construct a REGULAR HEPTAGON. Whose sides are 30mm long. (6 marks)

9. The FIGURE 2 below shows the Front Elevation of equilateral triangular pyramid drawn in Third angle orthographic projection. Draw the plan and End elevation in the direction of the arrow. (6 marks)

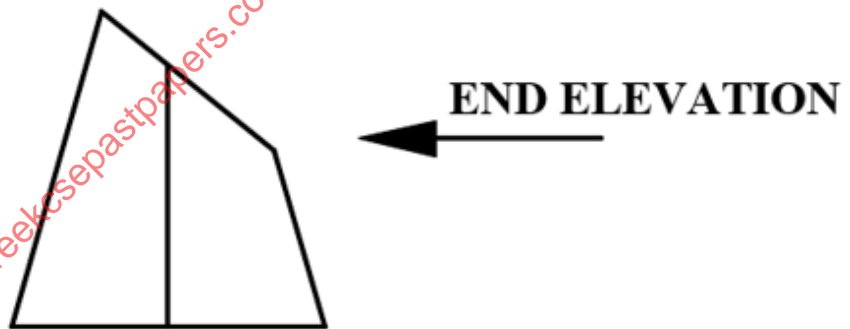

Fig 2

10. Define the following properties of materials: - (4 marks)

- i) Hardness.....
-
-
- iii) Toughness
-
-
- iv) Elasticity
-
-
- v) Plasticity.
-
-

SECTION B (20marks)

This question is compulsory.

Candidates are advised to spend no more than one hour on this question.

11. Figure 7 shows parts of a retort stand clamp drawn in first angle projection. Assemble the parts and draw FULL SIZE, the following views of the vice in third angle projection:

- A sectional front elevation along the cutting plane P - P
- End elevation in the direction of arrow X
- Plan

Insert **six** leading dimensions and do not show hidden details.

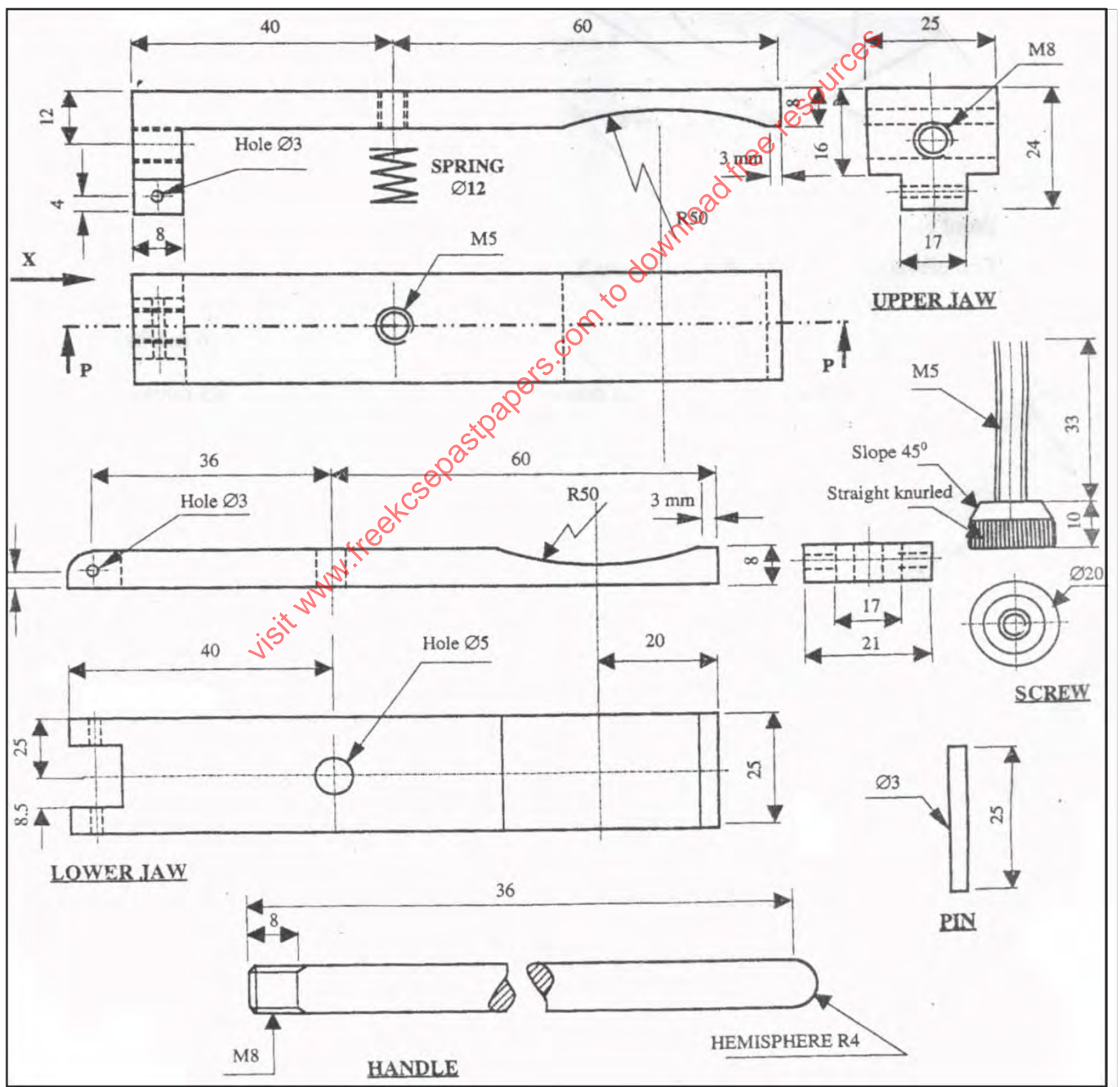

SECTION C (30marks)

12. Figure 8 shows the mouth of a cup having $\text{Ø}45\text{mm}$ and a handle protruding 10 mm.

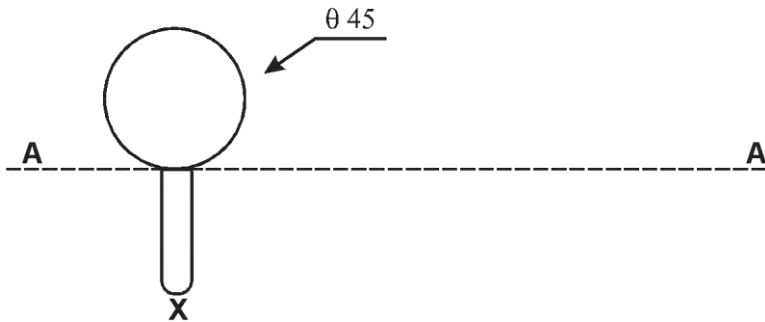

If the cup is rolled on the surface AA for one complete revolution, construction the locus of point X on the handle. (15 marks)

13. The figure below shows the front elevation of truncated hexagonal pyramid along X-X. Draw the following views accurately in first angle orthographic projection: (15 Marks)

- The Complete plan.
- The end elevation in the direction shown by the arrow Z.
- The true shape of the section.
- The auxiliary view

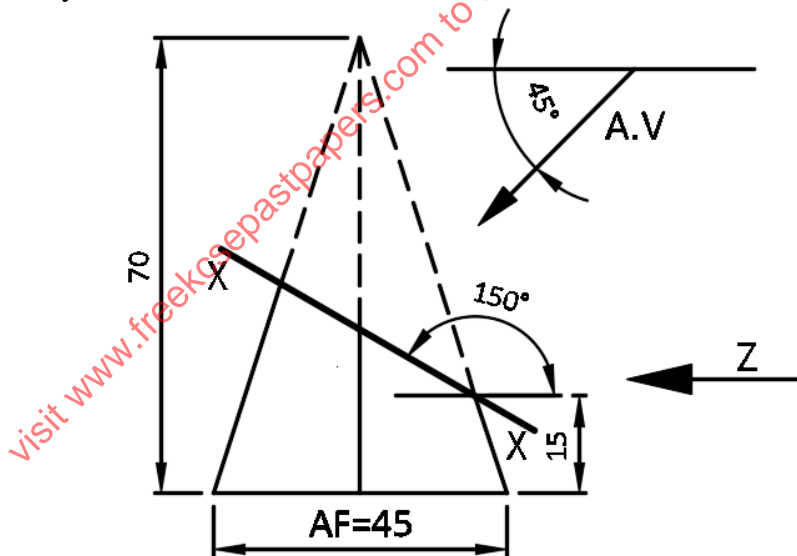

14. Make an isometric drawing from the three views given in Fig 10 below taking point X as the lowest point.
 (15 Mark)

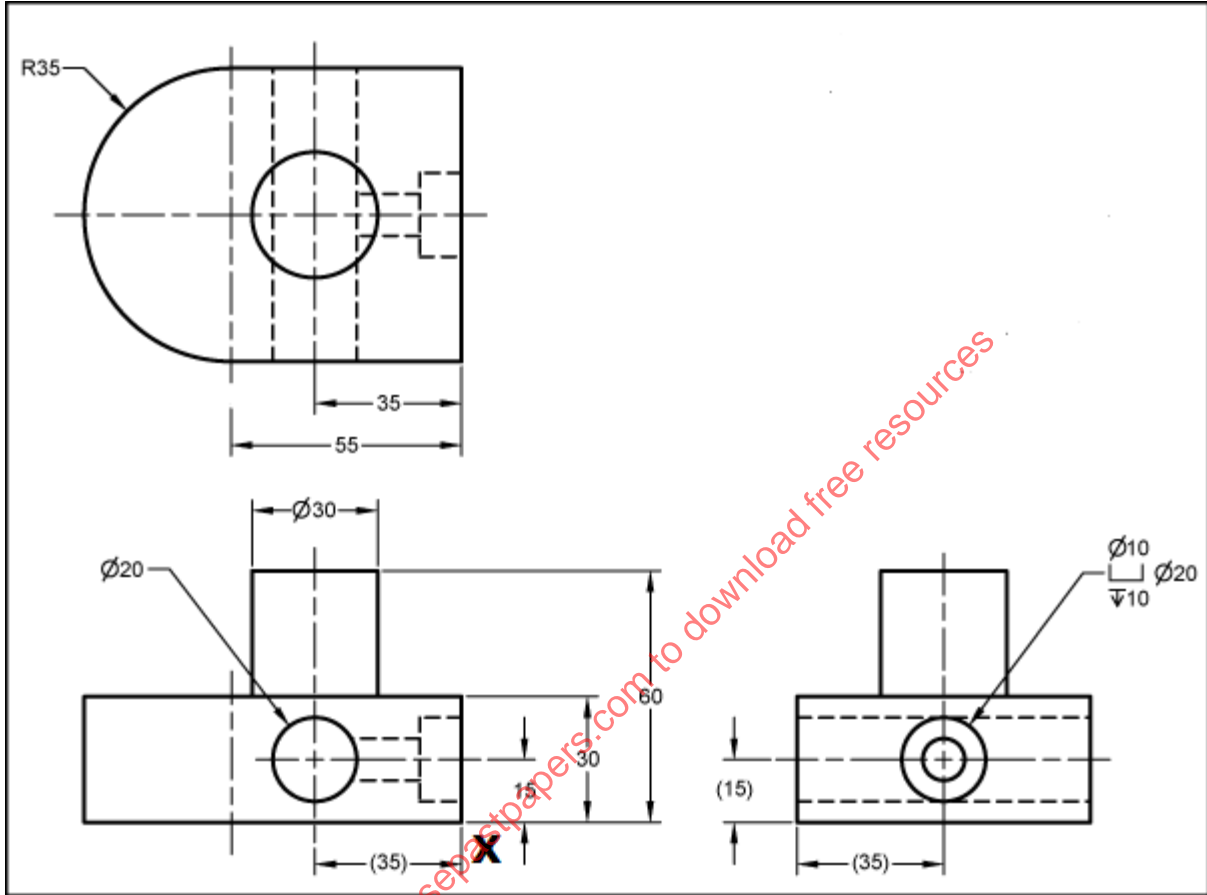

THIS IS THE LAST PRINTED PAGE.