

Name:..... Adm. No.
 Index No.
 Class:
 Signature:.....

232/3
 PHYSICS
 PRACTICAL
 JUNE 2022
 TIME: 2 ½ HRS

KASSU-JET EXAMINATION
Kenya Certificate to Secondary Education
PHYSICS PAPER 3
PRACTICAL

Instructions

- Write your name, admission number, class and signature in the spaces provided at the top of the page.
- Answer **all** the questions in the spaces provided in this paper.
- You are supposed to spend the first 15 minutes of the 2 ½ hours allowed for this paper reading the whole paper carefully before your start.
- Marks will be given for clear record of observations actually made, for their suitability and accuracy, and the use made of them.
- Candidates are advised to record their observations as soon as they are made.
- Electronic calculators and mathematical tables may be used.

FOR EXAMINER'S USE ONLY

Question(s)	Maximum Score	Candidate's Score
1	A ₁ 5	
	A ₂ 5	
	B 10	
2	A 3	
	B 17	
TOTAL	40	

This paper consists of 8 printed pages. Candidates are advised to check and to make sure all pages are printed.

QUESTION 1

PART A₁

(a) You are provided with the following apparatus.

- Helical spring with pointer
- One clamp, one stand and one boss
- A stop watch
- One 50g mass
- Two 100g masses

Proceed as follows:

(i) Suspend the spring vertically alongside a clamped metre rule as shown in the diagram so that the pointer slide along the millimeter scale of the metre rule as shown in the figure below.

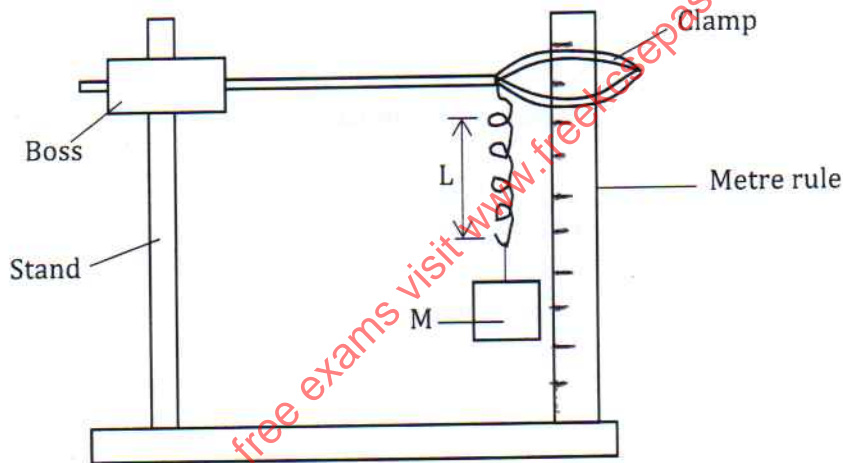

(ii) Measure the length L_0 of the unloaded spring. (1/2 mark)

$L_0 =$

(iii) Attach a mass of 100g on the spring and measure the new length L of the spring. Record this in the table. (5 marks)

Table

Mass (kg)	Weight (N)	$L(M)$	$e = (L - L_0)(M)$	$K = \frac{w}{e} \left(\frac{N}{M} \right)$
100				
150				
200				

- (iv) Calculate the change in length $e = (L - L_0)m$ due to the mass of 100g and record in the table.
- (v) Repeat the procedure in (i) - (iv) for mass of 150g and 200g.
- (vi) Calculate the value of K given:

$$K = \frac{w(N)}{e(M)} \text{ and find the average value of K.} \quad (1/2 \text{ mark})$$

K Average =

PART A₂

- (a) (i) Using the same set up as in Part A above, attach the 100g on the spring and support it to stop oscillating.
- (ii) Pull the mass through a small distance vertically downwards and release it to make vertical oscillations and record the time for 10 oscillations and determine the periodic time (s).
- (iii) Hence complete the table to get $T^2(s^2)$ and the value of $K = \frac{39.49 \times M(Kg)}{T^2 (S^2)}$ where $M =$ mass used and $T^2(S^2)$ is its periodic time T squared.
- (iv) Table (3^{1/2} marks)

Mass m(kg)	Time for 10 oscillations t(s)	T(s) $T = \left(\frac{t}{10}\right)$	$T^2(S^2)$	$\frac{39.49 \times M(Kg)}{T^2 (S^2)}$
1.00				
1.50				
2.00				

- (v) Find the average value of K. (1/2 mark)

PART B

(b) You are provided with the following:

- A meter rule
- Complete stand
- One 50g mass and a 100g mass
- Three Pieces of thread 30cm each
- Some water in a beaker
- Liquid L in a beaker
- Tissue paper.

Proceed with the experiment as follows:

(i) Balance the meter rule on the stand and record the reading at this point.

Balance point = (1 mark)

(For the rest of the experiment, the balancing thread must be placed at this position)

(ii) Set up the apparatus as shown in the figure 4 below;

Use the thread provided to hang the masses such that the positions of the support can be adjusted.

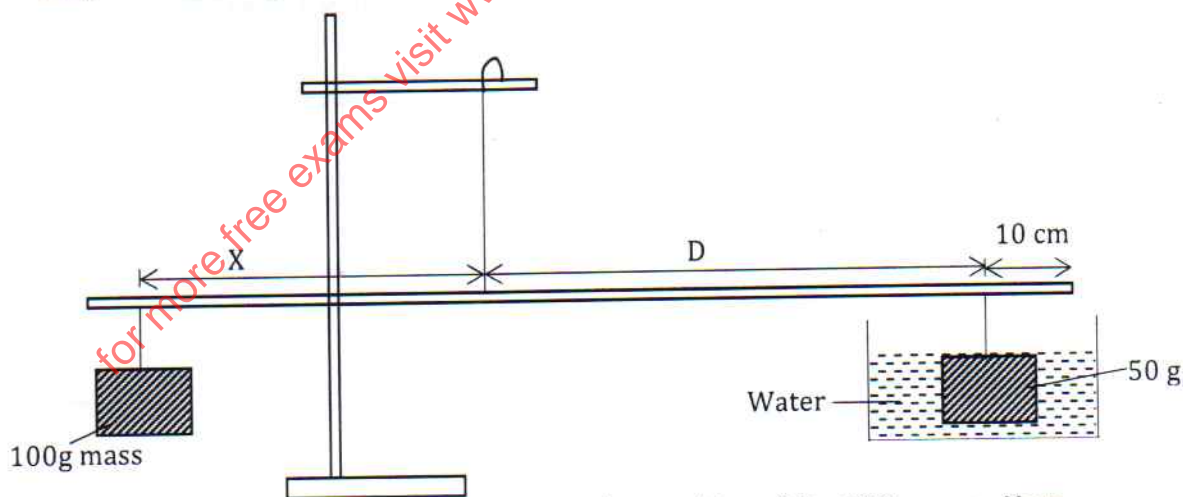

The balance point is attained by adjusting the position of the 100g mass. Note that the distance X and D are measured from the supporting string and the 50g mass is fully submerged in water.

Record the values of X and D.

X = (1 mark)

D = (1 mark)

Apply the principle of moments to determine the weight W_1 of the 50g mass in water and hence determine the upthrust U_w in water. (2 marks)

$W_1 = \dots\dots\dots$

$U_w = \dots\dots\dots$

Remove the 50g mass from the water and dry it using the tissue paper

- (iii) Now balance the metre rule when the 50g mass is fully immersed in the liquid L.
Record the value of the distance X.

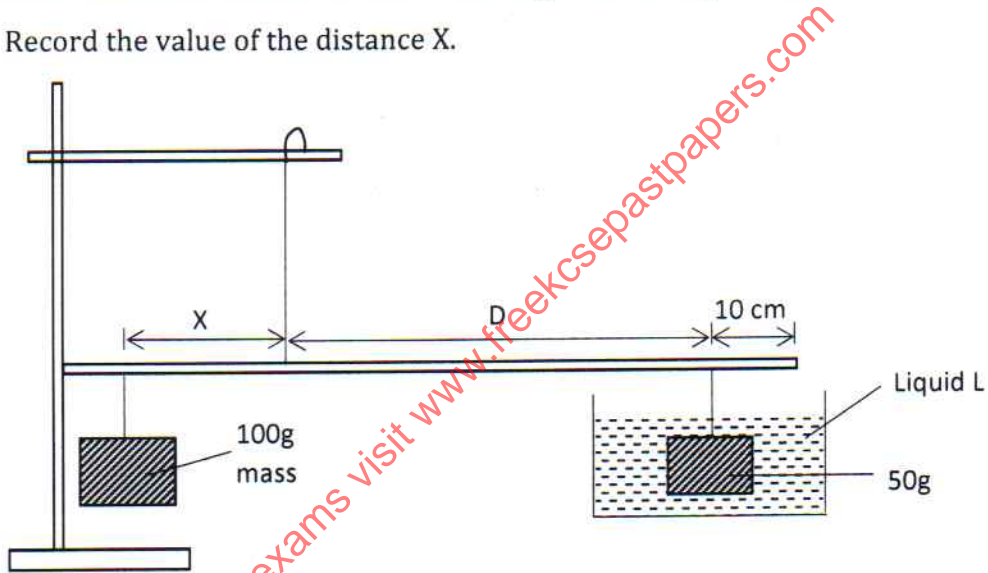

$X = \dots\dots\dots$ (1 mark)

Apply the principle of moments to determine W_2 of the 50g mass in the liquid L and hence determine the upthrust U_L in the liquid. (2 marks)

$W_2 = \dots\dots\dots$

$U_L = \dots\dots\dots$

- (iv) Determine the relative density R.D of the liquid L given that:

$R.D = \frac{U_L}{U_w}$ (1 mark)

- (v) Find the density of liquid L in Kg/m^3 (1 mark)

QUESTION 2

You are provided with the following apparatus

- Two dry cells and a cell holder
- A voltmeter
- An ammeter (0 – 1A)
- Potentiometer P
- A bulb and bulb holder
- 7 connecting wires
- 4 crocodile clips
- A switch S

PART A

Set up the circuit as shown below.
Ensure the switch is off.

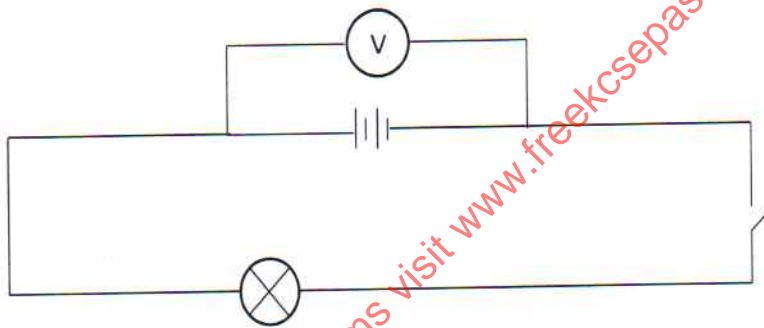

- (i) Record the reading of the voltmeter when the switch is open
 V_1 (1 mark)
- (ii) Close the switch and record the voltmeter reading.
 V_2 (1 mark)
- (iii) Explain the differences in the value of V_2 and V_1 (1 mark)

(i) Plot a graph of voltage against current.

(5 marks)

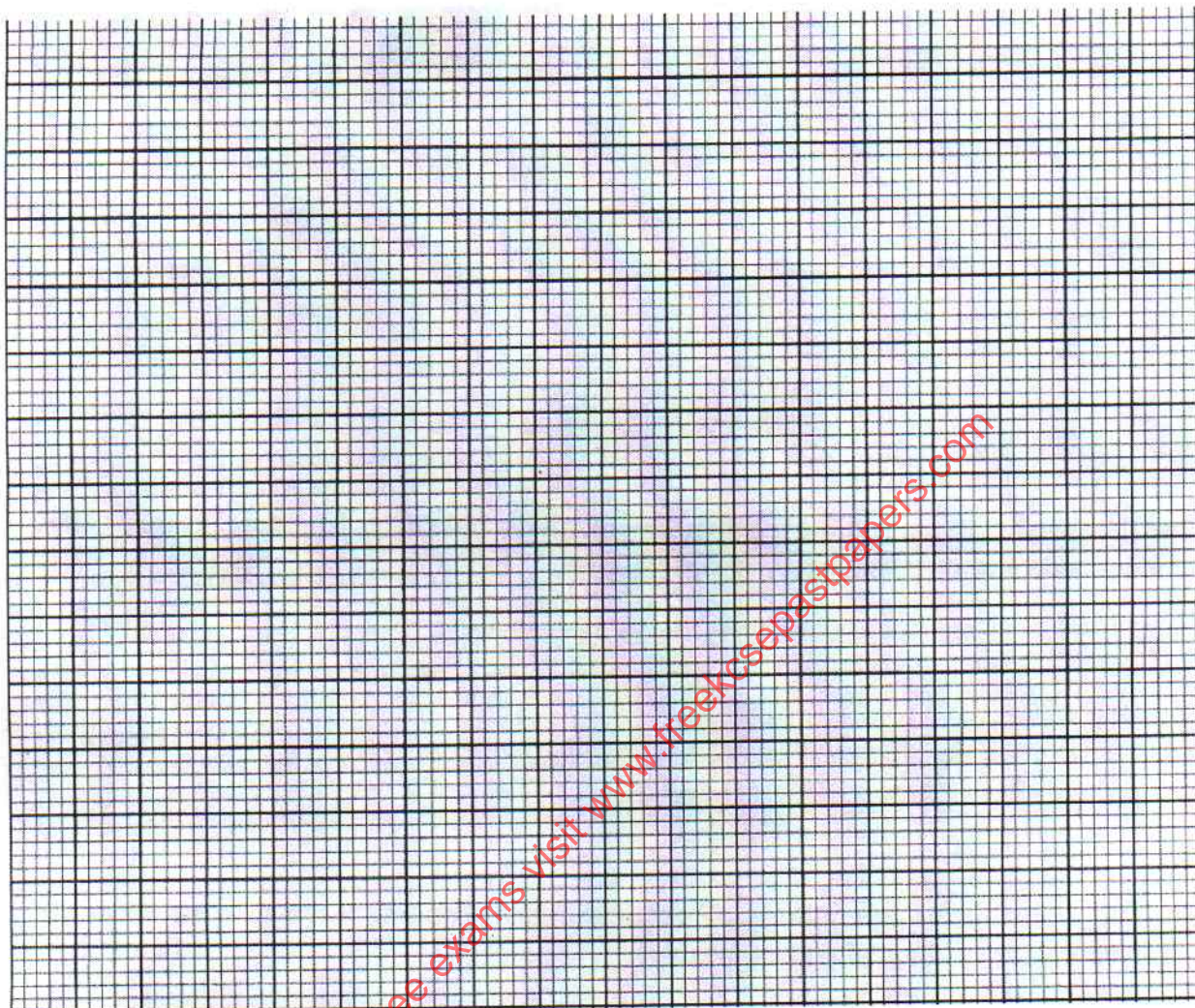

(ii) Determine the resistance of the bulb when voltage is 0.9V.

(3 marks)

(iii) Explain the nature of the curve in the graph.

(1 mark)