

NAMEADMN NOCLS

233/1

CHEMISTRY**PAPER 1 (THEORY)****TERM TWO, AUGUST 2022****TIME: 2 Hours****MURANG'A EXTRA COUNTY SCHOOLS EXAMINATION (MECS)****Instructions to Candidates**

- Write your name, admission number in the spaces provided above
- Answer all the questions in the spaces provided
- *KNEC* Mathematical tables and silent electronic calculator may be used.
- All the working must be shown clearly where necessary
- Candidates should answer questions in English.
- this exam consists of 11 printed pages

For Examiner's Use Only

| Question | Maximum Score | Candidate's Score |
|----------|---------------|-------------------|
| 1-29 | 80 | |

1.a) Define the term fuels (1mk)

.....
.....
.....

b) State two reasons why hydrazine is used as rocket propellant (2mks)

.....
.....
.....

2. Hydrogen can be placed in group VII and group I of the periodic table respectively. Use equations to explain (3mks)

.....
.....
.....
.....
.....

3. Study the set-up below and answer the questions that follow:-

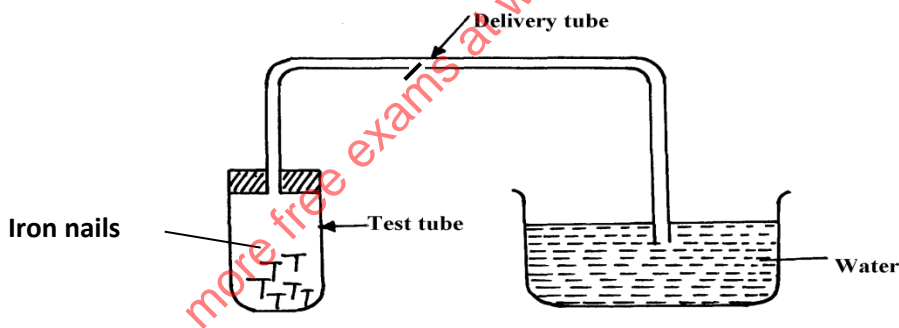

a) Name the process being investigated (1mk)

.....
.....

b) State **two** observations that would be made after one week. Explain (2mks)

.....
.....
.....

4.i) Apart from water softening list two other uses of sodium carbonate (2mks)

.....
.....

ii) Using an ionic equation show how sodium carbonate is used to soften hard water (1mks)

.....
.....

5. A form four student from Orawa secondary school found a white solid in a beaker that had two labels of zinc sulphate and aluminium sulphate respectively. Briefly explain how the student would test whether it was a compound of zinc or aluminium (3mks)

.....
.....
.....

6. The set-up below was used to prepare a carbon (II) oxide gas.

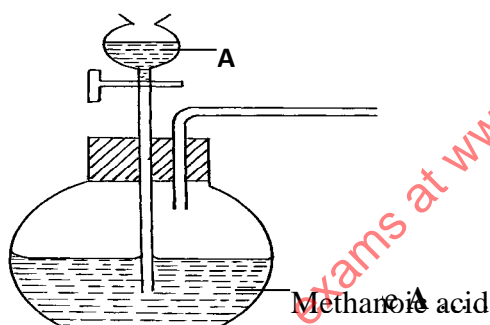

Methanoic acid (1/2mk)

(b) Complete the diagram to show how the gas can be collected (1 1/2 mks)

.....
.....

(c) Write the equation for the reaction (1mk)

.....
.....

7. A certain gas A was passed over a hot black metal oxide B, a brown solid was formed and a colorless liquid C that boiled at 105 °C, the liquid also changed a blue anhydrous cobalt (II) chloride paper to pink.

i. Name

a) Gas A.....($\frac{1}{2}$ mk)

b)Metal oxide B.....($\frac{1}{2}$ mk)

c)Colourless liquid C.....($\frac{1}{2}$ mk)

ii. State and explain a reason why the colourless liquid C boiled at 105°C (1mk)

.....

8. The following elements belong to the same group of the periodic table. (Letters do not represent the actual symbols)

| Element | Atomic radius (nm) | Ionic radius (nm) | First ionization Energy (KJ mol ⁻¹) |
|---------|--------------------|-------------------|---|
| A | 0.136 | 0.065 | 736 |
| B | 0.089 | 0.031 | 900 |
| C | 0.174 | 0.099 | 590 |

(i) Are the elements metals or non-metals? Explain (2mks)

.....

(ii) Which of the elements is the most reactive? (1mk)

.....

9. Zinc reacts with HCl according to the equation below.

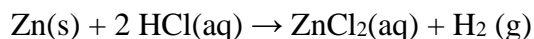

Complete the table to show how the factors given affect the rate of reaction above and give explanation (2 mks)

| Factors | Effect on rate | Explanation |
|---------|----------------|-------------|
|---------|----------------|-------------|

| | | |
|---------------------------------------|--|--|
| Using Zinc powder instead of granules | | |
| Heat the reactants | | |

10. Which allotrope of sulphur:

- a. Is stable at room temperature(1mk)
- b. Has prismatic crystals(1mk)
- c. Has higher density(1mk)

11. A certain flower was suspected to contain red and yellow pigments. Describe how the pigments could be separated (3mks)

.....

.....

.....

.....

.....

.....

12. A certain element has two isotopes with atomic mass 6 and 7 respectively. Given that the relative atomic mass is 6.94. Calculate the relative abundance of each isotope (2mks)

.....

.....

.....

13. The set up below was used to collect gas **K**, produced by the reaction between water and calcium metal.

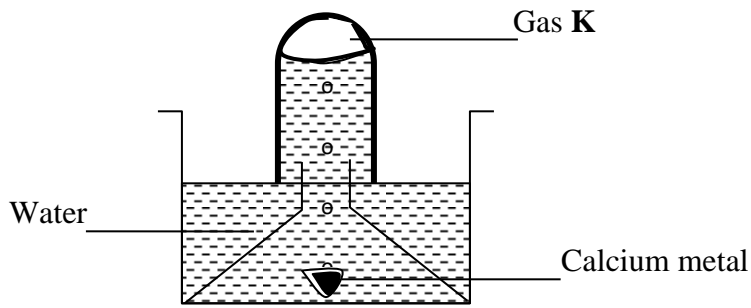

- i. State two observations made during the experiment (2mks)

.....

.....

.....

- ii. Write an equation for the reaction taking place. (1mk)

.....

.....

14. State the properties of concentrated sulphuric (vi) acid demonstrated in the following reactions

- i. Reacts with sodium chloride to form hydrogen chloride gas (1mk)

.....

- ii. Reacts with copper metal to form sulphur (iv) oxide (1mk)

.....

15. 1.0g sample of limestone was allowed to react with 100cm^3 of 0.2M hydrochloric acid. The excess acid required 24.8cm^3 of 0.1M sodium hydroxide solution for complete neutralisation.

Calculate the percentage of calcium carbonate in the limestone (3mks)

.....

.....

.....

.....

.....

.....

.....

.....

.....

.....

.....

16. In an experiment, dry chlorine gas was reacted with aluminium as shown in the diagram below

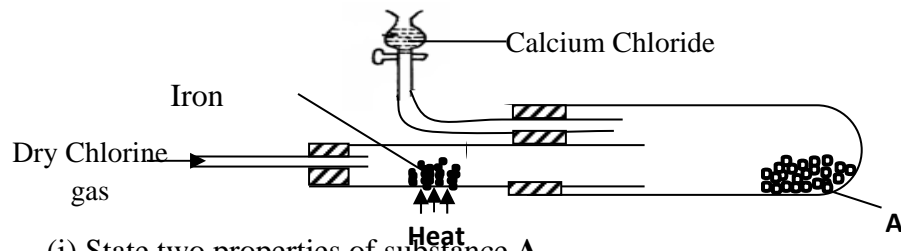

(i) State two properties of substance A (2mk)

.....

.....

.....

(ii) Write an equation for the reaction that took place in the combustion tube (1mk)

17. State one use each of the following apparatus in the laboratory (3mks)

i. Desiccator

.....

.....

ii. Crucible

.....

.....

iii. Deflagrating spoon

.....

.....

18. Using dots and crosses to represent electrons draw diagrams to represent bonding in (2mks)

i. H_3O^+ (H=1, O=8)

.....

.....

.....

.....

.....

.....

.....

.....

19. Carbon powder and copper (ii) oxide are both black in colour. Suggest two reactions that can be used to differentiate them and state the observation in each case. (3mks)

.....
.....
.....
.....
.....
.....

20. Starting with sodium metal explain how sodium hydrogen carbonate crystals can be prepared (3mks)

.....
.....
.....
.....
.....
.....

21. i) Define the term simple acid base-indicator (1mk)

.....
.....
.....

ii. State two disadvantages of using simple acid-base indicators (2mks)

.....
.....
.....
.....

22. i State two applications of complex ions in industries (2mks)

.....
.....
.....
.....

23. What do the following abbreviations stand for? (2mks)

IUPAC.....

DDT.....

24.i. Differentiate between nuclear fission from nuclear fusion (2mks)

.....

.....

.....

.....

ii. A radioactive cobalt (${}_{28}^{61}\text{Co}$) undergoes decay by emitting a beta particle and forming

Nickel atom. Write a balanced decay equation for the above change (1mk)

.....

.....

.....

.....

25. The following are heats of combustion of carbon, hydrogen and ethanol the following substances calculate the heat of formation of ethanol

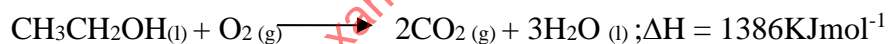
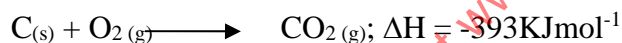

a) Draw an energy cycle diagram to represent the heat of formation of ethanol (1mk)

.....

.....

.....

.....

.....

b) Calculate the heat of formation of ethanol (2mks)

.....

.....

.....

.....

26. The diagram below shows an electrochemical cell:

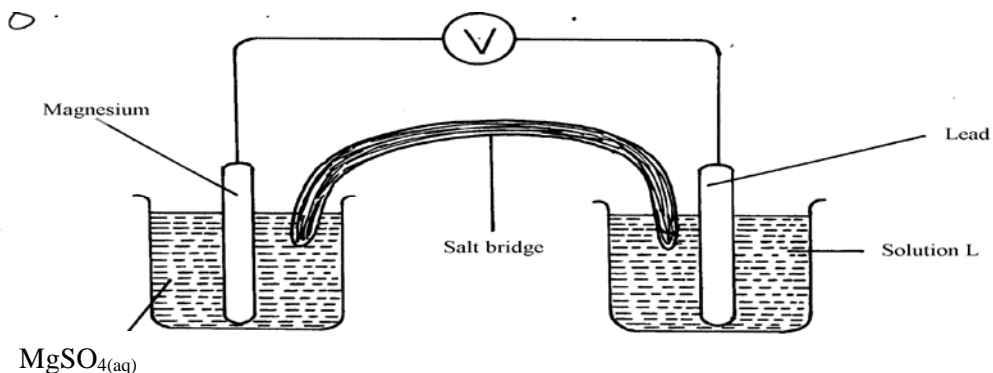

a) Give the formulae of the possible salt L (1mk)

.....

.....

(b) On the diagram show the direction of movement of electrons (1mk)

.....

(c) Write the cell representation (1mk)

.....

.....

27. a) State the Graham's law (1mk)

.....

.....

.....

.....

b). 100cm³ of Carbon (IV) oxide gas diffused through a porous partition in 30seconds. How long would it take 150cm³ of Nitrogen (IV) oxide to diffuse through the same partition under the same conditions? (C = 12.0, N = 14.0, O = 16.0) (2mks)

.....

.....

.....

.....

28. A compound Q was oxidised by acidified potassium dichromate (vi) to form substance Z. Substance Z reacts with Q to form a pleasantly smelling compound ethylethanoate.

i. Name substance Q and Z (1mk)

.....
.....
.....

ii. Write an equation for the reaction between

a. Substance Q and potassium metal (1mk)

.....
.....

b. Substance Z and sodium carbonate (1mk)

.....
.....

29. i. State two distinctive features of a dynamic equilibrium. (2mks)

.....
.....
.....
.....

ii. Explain the effect of increase in pressure on the following equilibrium (1mk)

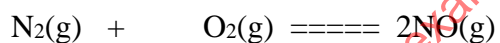

.....
.....
.....
.....

THIS IS THE LAST PRINTED PAGE