

Name Class.....
Sign.....

121/2

MATHEMATICS

Date.....

Paper 2

March 2023

Pre-Mock Examination 2023

2 ½ hours

Instructions to candidates

- Write your name and class in the spaces provided above.
- Sign and write the date of examination in the spaces provided above.
- The paper contains **TWO** sections: **Section I** and **Section II**.
- Answer **ALL** the questions in **Section I** and any five questions from **Section II**
- All answers and working must be written on the question paper in the spaces provided below each question.
- Show all the steps in your calculations, giving your answers at each stage in the spaces below each question.
- Non – programmable silent electronic calculators and **KNEC Mathematical tables** may be used, except where stated otherwise.

For Examiner’s use only.

Section I

1	2	3	4	5	6	7	8	9	10	11	12	13	14	15	16	Total

Section II

17	18	19	20	21	22	23	24	Total

Grand Total

--

This paper consists of 14 printed page .Candidates should check the question paper to ascertain that all the pages are printed as indicated and no questions are missing.

SECTION I

1. Solve the simultaneous equation $y^2 = x - 1$
 $y^4 = 7 - 3x$ for the real values of x and y (3marks)

2. $\underline{B} = \begin{pmatrix} 2 - x & x \\ 3 & 2 + x \end{pmatrix}$ Find the values of x for which \underline{B} has no inverse (3marks)

3. The 50th term of an Arithmetic Progression (AP) is seven times the 20th term. The sum of the first 50 terms is 1050. Calculate the sum of the first 29 terms of the (AP) (3marks)

4. Under transformation whose matrix is $\begin{pmatrix} x - 1 & 3 \\ 1 & x + 1 \end{pmatrix}$ an object of area 12cm^2 is mapped onto an image whose area is 60cm^2 . Find the possible values of x (3marks)

5. From a ship C, a lighthouse A is 20km away on a bearing of 060° while a lighthouse B is 30km on a bearing of 300° . Calculate the direct distance between the lighthouses (3marks)

6. Mr. Emato intends to purchase a piece of land valued at shs 850,000. He takes two loans each half the value of the land from two different banks. Each loan is repayable after 4 years. The first bank charges simple interest at 15% p.a while the second one charges compound interest at 10% p.a. Calculate the total interest paid to the banks after 4 years (3marks)

7. The figure below shows external intersection of two chords SM and NK which are produced to meet at P. Given that SOK is the diameter of the circle and that $SM=15\text{cm}$, $MP=18\text{cm}$ and $PK=22\text{cm}$,

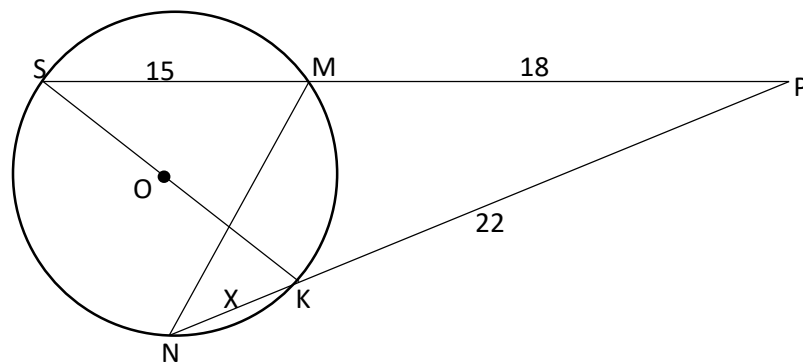

- a) Calculate the value of x representing the length of chord NK (2marks)
- b) Calculate the radius of the circle (2marks)

8. Point C divides AB in the ratio 3:1. The position vectors of A and C are given as $\frac{1}{9}\mathbf{j} + 7\mathbf{k}$ and $6\mathbf{i} + \frac{1}{3}\mathbf{j} + 9\mathbf{k}$ respectively. Find the position vector of B (3marks)

9. Use completing the square method to solve for x in $3x^2 - 25x + 8 = 0$ (3marks)

10. Paint A costs Shs 500 per litre, paint B costs shs 600 per litre. In what ratio must A be mixed with B to produce a mixture worth shs 560 per litre. (3marks)

11. Island P is (30°N , 31°E) and another island Q is located at a distance of 4365 nautical miles east of P. Find the position of island Q (3marks)

12. Determine the coordinates of the point on a curve $y = x^2 - 6x + 8$ where the gradient is -3. Hence determine the equation of the tangent and the normal at this point (4marks)

13. Solve for y in the equation $(\log_3 y)^2 - \log_3 27 = \log_3 y^2$ (3marks)

14. Hibbo bought a new computer on hire purchase. The cash price of the computer was sh 60,000. He paid a deposit of sh 10,000 followed by 24 equal monthly instalments of sh 3,000. Calculate the monthly rate at which the compound interest was charged (3marks)

15. The quantities L, M and N are such that L varies directly as the square root of M and inversely as the cube of N . Find the percentage change in L if M increases by 21% and N decreases by 16% (3marks)

16.

a) Expand and simplify $\left(2 - \frac{1}{2}x\right)^5$ up to the fourth term. (1mark)

b) Use your expansion in a) above to evaluate 1.9^5 correct to 3 decimal places (2 marks)

SECTION II

17. ABCD is a quadrilateral with coordinates A(2, 1), B(3, 2), C(3, 4) and D(0, 3). ABCD is mapped onto A'B'C'D' under transformation T given by a shear with x-axis invariant such that A'(4, 1).
- a) T=determine the 2 x 2 transformation matrix representing T and hence determine the coordinates of B', C' and D' (2marks)
- b) A'B'C'D' is transformed to A''B''C''D'' under a transformation H such that A''(-6, -9) and D''(-12, -15). Determine the 2x2 matrix representing H and hence determine the coordinates of B'' and C'' (4marks)
- c) A''B''C''D'' mapped onto A'''B'''C'''D''' under a transformation V representing a reflection in the line $y = -x$. Determine the 2x2 matrix representing V and hence determine the coordinates of A'''B'''C'''D''' (2marks)
- d) Determine the single matrix that will map A'''B'''C'''D''' back to ABCD (2marks)

18.

- a) Complete the table below for the functions of $y = 2 + 2\sin 3x^\circ$ and $y = 3 - \cos \frac{3}{2}x^\circ$ for values $0 \leq x \leq 360^\circ$ (2marks)

0°	0	30	60	90	120	150
$2 + 2\sin 3x^\circ$		4.0				
$3 - \cos \frac{3}{2}x^\circ$				3.7		

180	210	240	270	300	330	360
						2.0
3.0			2.3			

- b) On the grid provided, draw the graphs of $y = 2 + 2\sin 3x^\circ$ and $y = 3 - \cos \frac{3}{2}x^\circ$ for values $0 \leq x \leq 360^\circ$ (4marks)

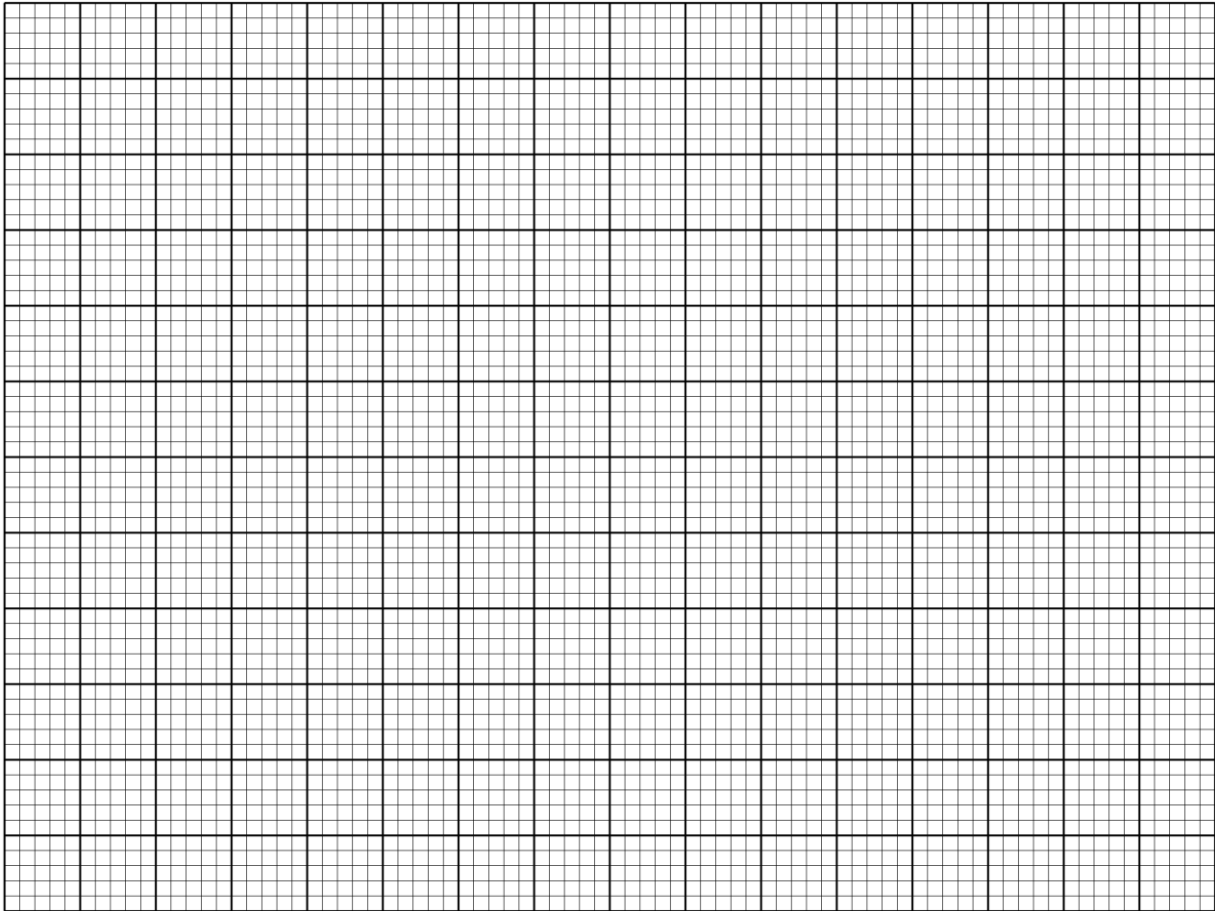

- c) State the period and amplitude of each function (2marks)
 d) Show that $1 = 2\sin 3x + \cos 1.5x$ represents the equation of the intersection of the two functions. Use your graph to solve this equation (2marks)

19. A welder requires 6 hours to make a bed and 9 hours to make a door. It takes the welder at least 216 hours to make x beds and y doors. The labour cost of making a bed is Ksh 500 and that of a door is Ksh 1000. The total labour cost should not exceed Ksh 24,000. The welder must make at least 16 beds and more than 10 doors in order to make a profit.

a) Form all the linear inequalities which will represent the above information (3marks)

b) On the grid provided, draw the inequalities and shade the unwanted region (4marks)

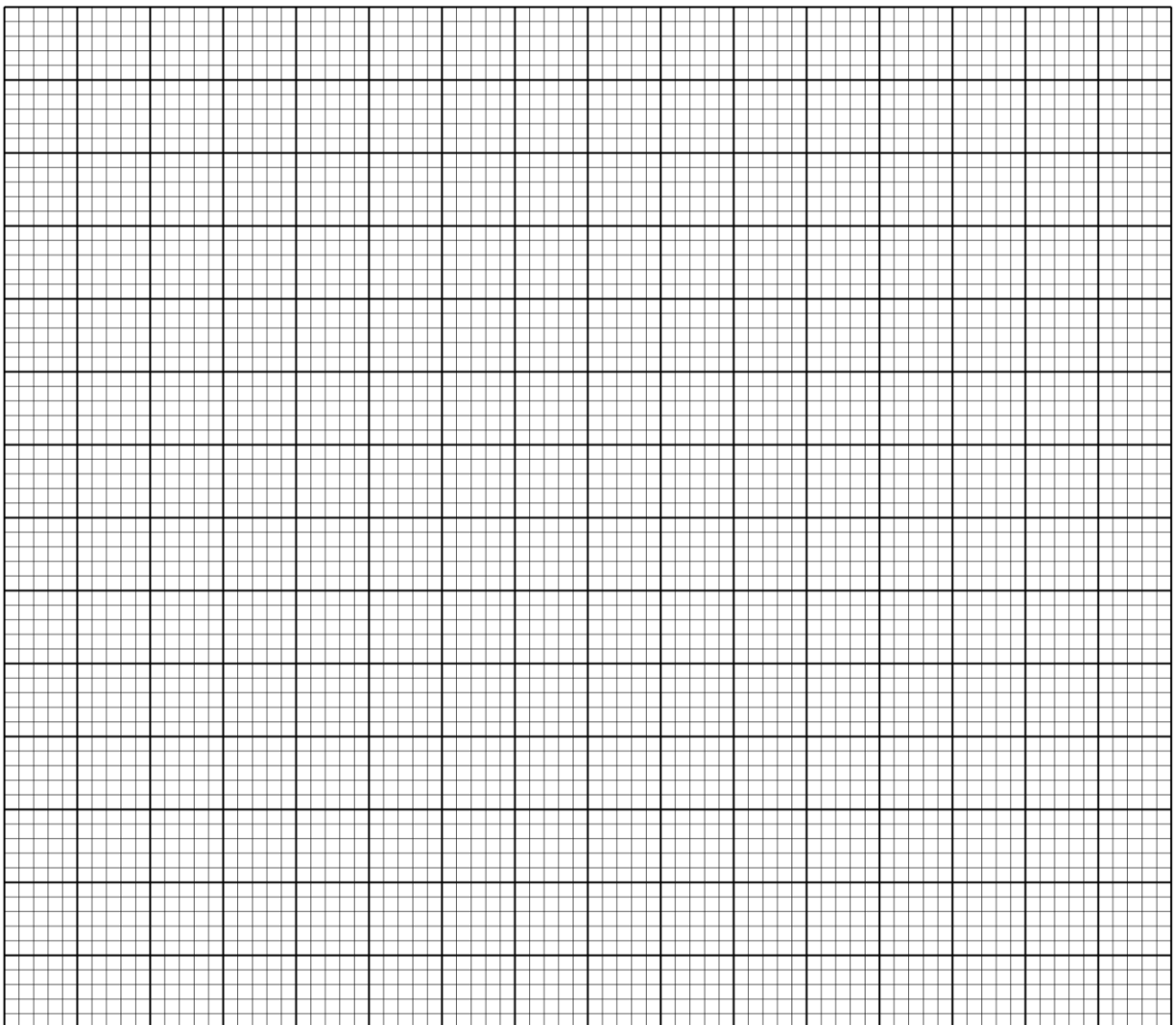

c) The welder makes a profit of Ksh 400 on a bed and Ksh 1000 on a door. Use the graph and a search line to determine the maximum profit the welder can make (3marks)

20. A fan belt runs over two pulleys of radii 10cm and 15 cm as shown below. If the centres A and B of the pulleys are 40cm apart,

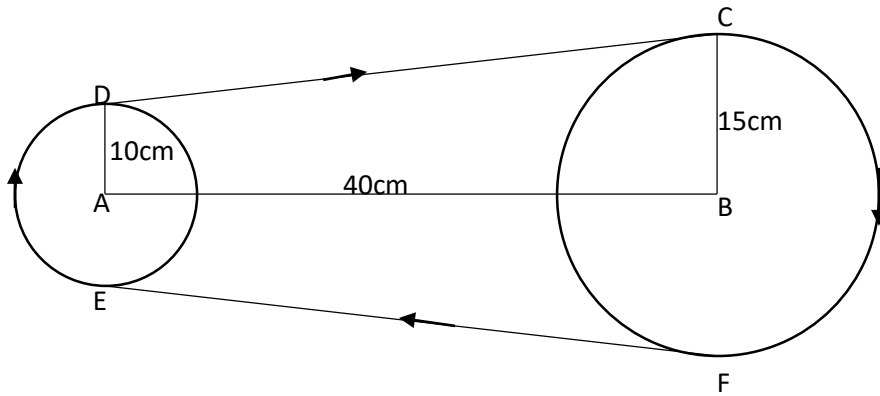

Calculate:

- i. The length of CD (3 marks)

- ii. Arc length DE (3 marks)

- iii. Arc length CF (2 marks)

- iv. Total length of the belt (2 marks)

21. The table below shows the marks obtained by 75 students in a mathematics test.

Marks	40-49	50-59	60-69	70-79	80-89
No. of students	5	14	16	17	23

a) Using 64.5 as the assumed mean determine the actual mean (4marks)

b) The 30th decile (2marks)

c) Calculate the standard deviation of the data (4marks)

22. A particle moves such that t seconds after passing a given point O , its distance s meters from O is given by $s = t(t - 2)(t - 1)$ find ;

a) Its displacement when $t = 1s$ (1mark)

b) Its velocity when $t = 2s$ (2marks)

c) Its maximum velocity (3marks)

d) The time when the particle is momentarily at rest (2marks)

e) Its acceleration when $t = 3s$ (2marks)

23. A fruit vendor has three bags P, Q and R which contains a mixture of oranges and lemons. Bag P contains 12 oranges and 18 lemons, bag Q contains 15 oranges and 16 lemons and bag R contains 10 oranges and 20 lemons. The fruit vendor selected a bag at random and picked two fruits from it, one at a time, without replacement.

a) Illustrate the information in a tree diagram (2marks)

b) Find the probability that the fruits are

i) An orange and a lemon (2marks)

ii) Lemons and from bag R (2marks)

iii) Of the same bag and from bag P (2marks)

iv) Of different types and not from bag Q (2marks)

24. The first terms of an arithmetic progression is 700. The sum of the first 10 terms of the arithmetic progression is 24,800.

a) Find the common difference of the progression (4marks)

b) Given that the sum of the first n terms of the AP is 109,000, find n (3marks)

c) Find the sum of the first 20 terms of the progression (3marks)